



8th International Conference on Sustainability in Energy and Buildings, SEB-16, 11-13
September 2016, Turin, ITALY

Energy efficient building HVAC control algorithm with real-time occupancy prediction

Jie Shi^a, Nanpeng Yu^{a,*}, Weixin Yao^b

^aDepartment of Electrical and Computer Engineering, University of California Riverside, 900 University Ave., Riverside, CA 92507, USA

^bDepartment of Statistics, University of California Riverside, 900 University Ave., Riverside, CA 92507, USA

Abstract

A large amount of energy is wasted through inefficient operation of heating, ventilation, and air conditioning (HVAC) system due to the lack of reliable building occupancy measurement and prediction. To mitigate this problem, an innovative change-point logistic regression model is developed to provide an accurate forecast of building occupancy. A novel building HVAC control algorithm is then developed by embedding the occupancy prediction model into the model predictive control (MPC) framework. The occupancy-based MPC algorithm tries to minimize building electricity consumption and maximize building occupants' comfort at the same time. A penalty factor is introduced which allows building occupants to determine the optimal trade-off between comfort and energy efficiency. Numerical simulation results show that the proposed HVAC control strategy with real-time occupancy prediction not only reduces electricity consumption but also improves building occupants' comfort.

Published by Elsevier Ltd. This is an open access article under the CC BY-NC-ND license

(<http://creativecommons.org/licenses/by-nc-nd/4.0/>).

Peer-review under responsibility of KES International.

Keywords: Energy efficient building; HVAC; Occupancy prediction; MPC; Logistic regression

1. Introduction

Buildings account for approximately 40% of the world's energy consumption [1]. In the United States alone, buildings are responsible for nearly 40% of the greenhouse gas emission and 70% of the electricity usage. Adoption of energy efficient building controls can significantly reduce the greenhouse gas emissions and electricity bill for building owners. In residential and commercial buildings, HVAC system, plug loads and lighting loads consume majority of the electricity. In particular, HVAC systems account for around 50% of the total building energy consumption [2]. Given that more and more buildings are controlled by Building Automation System (BAS), one of the most effective ways of reducing the energy consumption of the HVAC system is to improve the existing building control strategies.

MPC has been widely adopted in building HVAC system controls to improve the energy efficiency [3–7]. To accommodate the weather uncertainty, stochastic model predictive control (SMPC) algorithm is proposed for building climate control [8]. Building occupancy prediction is incorporated into a real-time MPC framework for HVAC system

* Corresponding author. Tel.: +1-951-827-3688.

E-mail address: nyu@ece.ucr.edu

by using Hidden Markov Model based occupancy detection method [9]. In [10] and [11], building occupancy predicted by using simple historical proportion method and inhomogeneous Markov chain are incorporated into the building HVAC control algorithms. The effectiveness of occupancy based MPC algorithms have been demonstrated through simulations. The simulation results in [12] have shown that a higher energy saving level can be achieved with more accurate building occupancy prediction algorithm.

Nomenclature

$R_{s,i}$	Solar radiation on Wall i (W)
T_{out}	Temperature of outside air ($^{\circ}\text{C}$)
$T_{w,i}$	Temperature of Wall i ($^{\circ}\text{C}$)
T_{room}	Temperature of the room air ($^{\circ}\text{C}$)
$C_{w,i}$	Thermal capacitance of Wall i ($\text{J}/^{\circ}\text{C}$)
C_{air}	Thermal capacitance of the room air ($\text{J}/^{\circ}\text{C}$)
$R_{cd,i}$	Thermal resistance of the conduction inside Wall i ($^{\circ}\text{C}/\text{W}$)
$R_{cv,out,i}$	Thermal resistance of the convection between Wall i and the outside air ($^{\circ}\text{C}/\text{W}$)
$R_{cv,in,i}$	Thermal resistance of the convection between Wall i and the room air ($^{\circ}\text{C}/\text{W}$)
Q_{in}	Internal heat gain (W)
C_{sh}	Specific heat of the supply air ($\text{J}/\text{kg}\cdot^{\circ}\text{C}$)
\dot{m}	Mass flow rate of the supply air (kg/s)
T_{supply}	Temperature of the supply air ($^{\circ}\text{C}$)
\mathbf{x}	State vector
\mathbf{D}	Disturbance vector
$y(k)$	Occupancy state of a building at time interval k
β_0	Intercept term in the logistic regression
β	Coefficient vector in the logistic regression
\mathbf{x}_c	Vector of covariates in the logistic regression
Y	Response variable in the logistic regression
h	Time index
β_i	The i th coefficient in the logistic regression with change points
h_i	The i th change point
p	Number of change points
N_k	Number of data points in the testing dataset
$W_{chiller}$	Electric power of the chiller (W)
W_{fan}	Electric power of the fan (W)
COP	Coefficient of performance for the chiller
k_{fan}	Fan power constant
W_H	Electric power of the HVAC system (W)
λ	Penalty factor ($\text{W}/^{\circ}\text{C}^2$)
T_{desire}	Desired room temperature ($^{\circ}\text{C}$)
u_{min}	Lower bound of the control variable u ($\text{J}/\text{kg}\cdot^{\circ}\text{C}$)
u_{max}	Upper bound of the control variable u ($\text{J}/\text{kg}\cdot^{\circ}\text{C}$)
T_{min}	Lower bound of the room temperature T_{room} ($^{\circ}\text{C}$)
T_{max}	Upper bound of the room temperature T_{room} ($^{\circ}\text{C}$)
T_{TS}	Center of Taylor series expansion for the room temperature T_{room} ($^{\circ}\text{C}$)
u_{TS}	Center of Taylor series expansion for the control variable u ($\text{J}/\text{kg}\cdot^{\circ}\text{C}$)
K	Total number of time intervals in the testing period

In this paper, an innovative building occupancy prediction algorithm based on logistic regression model with change-points is proposed. The logistic regression model with change-points outperforms the historical proportion

and inhomogeneous Markov chain model and yields lower forecast error. A novel energy saving control strategy for the HVAC system is then proposed, which integrates the occupancy prediction model into the MPC framework. In the proposed control strategy, a penalty factor can be adjusted by the building occupants to select the optimal trade-off between energy efficiency and comfort. Simulations with real occupancy data are carried out to validate the proposed control strategy.

The rest of the paper is organized as follows. Section 2 presents the system model including the building thermal model and the occupancy prediction model. Section 3 describes the proposed control strategy. Section 4 presents the simulation results and discussion. The conclusions are stated in Section 5.

2. System modeling

2.1. Thermal modeling of buildings

The primary heat storage elements of buildings are the walls, floor, and roof. The heat transfer processes have three basic modes, i.e., conduction, convection and radiation [13]. In the building thermal model, the heat transfer inside the walls is governed by the conduction. The heat transfer between the walls and the air is governed by the convection. The solar heat gain from the sun is governed by the thermal radiation process. Treating the heat flow as current, the temperature as voltage and the heat storage elements as capacitors, we can transform the building thermal model into a resistor-capacitor (RC) circuit model. Many studies have been conducted on the configuration of RC models [9,14–16]. We adopt a 2R1C model similar to the one presented in [14], which is simple yet accurate. In this

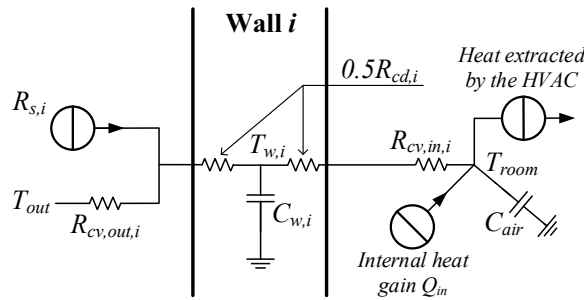

Fig. 1. RC circuit of a single wall.

paper, we consider a single zone¹ building including four external walls, the roof and the floor, which is assumed to be conditioned by a variable air volume (VAV) system with air handling unit (AHU). The modeling method can be extended to more complex buildings with multiple zones. Fig. 1 gives the RC circuit that connects the solar radiation, outside air, a single wall and the room air. Based on this RC circuit, we formulate the following equation to describe the thermal dynamics of Wall i :²

$$C_{w,i} \frac{dT_{w,i}}{dt} = \frac{T_{out} - T_{w,i}}{R_{cv,out,i} + 0.5R_{cd,i}} + \frac{T_{room} - T_{w,i}}{R_{cv,in,i} + 0.5R_{cd,i}} + \frac{R_{cv,out,i}}{R_{cv,out,i} + 0.5R_{cd,i}} R_{s,i} \quad (1)$$

By combining the thermal dynamic equations of the external walls, the roof and the floor, the dynamic equation for the room temperature can be derived as follows:

$$C_{air} \frac{dT_{room}}{dt} = \sum_{i=1}^6 \frac{T_{w,i} - T_{room}}{R_{cv,in,i} + 0.5R_{cd,i}} + Q_{in} - C_{sh} \dot{m} (T_{room} - T_{supply}) \quad (2)$$

¹ A zone is an individual conditioned space which is controlled by one thermostat.

² The wall temperature and the room air temperature are the average temperature of the wall and room air respectively. Wall 1 to Wall 4 represent the four external walls. Wall 5 and Wall 6 represent the roof and floor.

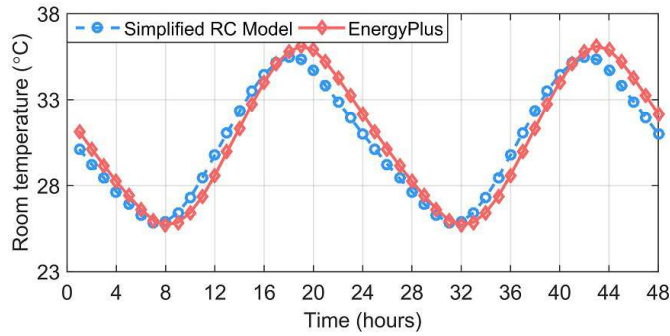

Fig. 2. Room temperature simulated from the simplified RC circuit model and EnergyPlus.

where Q_{in} denotes the internal heat gain. C_{sh} , \dot{m} and T_{supply} represent the specific heat, mass flow rate and temperature of the supply air respectively. Note from equations (1) and (2) that the thermal model of the single-zone building is a seventh order nonlinear system with multiple inputs. By defining the control variable u as the mass flow rate of supply air \dot{m} , the system equations can be expressed in the state-space as follows:

$$\dot{\mathbf{x}} = \mathbf{A}\mathbf{x} + \mathbf{f}(\mathbf{x}, u) + \mathbf{D} \quad (3)$$

where $\mathbf{x} = [T_{w,1}, \dots, T_{w,6}, T_{room}]^T$ is the state vector. \mathbf{D} is the disturbance vector that contains solar radiation $R_{s,i}$, outside air temperature T_{out} and internal heat gain Q_{in} .

Note that the disturbance vector \mathbf{D} can be estimated in practice. For instance, the solar radiation can be predicted through artificial neural network (ANN) techniques [17]. The outside air temperature can be forecasted on an hourly basis by using Kalman filter [8]. The internal heat gain can be estimated from the nominal power of the electric devices and the number of occupants in the building.

To validate the proposed building thermal model, we conducted simulations on MATLAB and compared our results with that of EnergyPlus [18]. The test building model has a dimension of $10m \times 10m \times 3m$ which is assumed to be located in Riverside, California. The weather information is derived from [19]. The thermal resistances and thermal capacitances in the proposed model are calculated from the corresponding parameters set in the EnergyPlus such as the wind speed, the materials, the thickness of the walls, etc. Fig. 2 gives the simulated room temperatures of the proposed model and EnergyPlus. The simulated temperature time series from the simplified RC circuit model closely track that of the EnergyPlus model. This observation demonstrated the validity of the simplified thermal model of the test building.

2.2. Occupancy prediction

In this paper we propose a novel statistical model to predict the probability of a building being occupied at certain time. Define $y(k)$ as the occupancy state of a building at time interval k . If the building is occupied at time interval k , then $y(k) = 1$, otherwise $y(k) = 0$. Denote the probability of $y(k) = 1$ as $P(y(k) = 1)$. Thus our goal is to predict $P(y(k) = 1)$. Since the occupancy state is a binary variable, we propose a logistic regression model with change-points to characterize the statistical properties of the historical data and predict the future occupancy states.

The logistic regression model is a generalized linear regression model which is widely used for the analysis of binary data. Its basic form is given as follows [20]:

$$\text{logit}(p(\mathbf{x}_c)) = \ln\left(\frac{p(\mathbf{x}_c)}{1 - p(\mathbf{x}_c)}\right) = \beta_0 + \boldsymbol{\beta}^T \mathbf{x}_c \quad (4)$$

where $p(\mathbf{x}_c) = P(Y = 1|\mathbf{x}_c)$, logit is the link function that transforms the probability $p(\mathbf{x}_c)$ into a linear regression, and \ln denotes the natural logarithm. Then,

$$P(Y = 1|\mathbf{x}_c) = \frac{e^{\beta_0 + \boldsymbol{\beta}^T \mathbf{x}_c}}{1 + e^{\beta_0 + \boldsymbol{\beta}^T \mathbf{x}_c}} \quad (5)$$

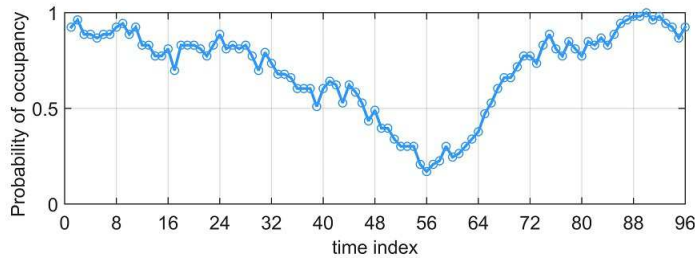

Fig. 3. Probability of occupancy calculated based on the simple proportion method.

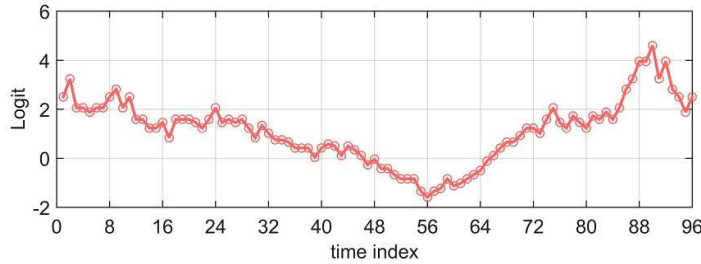

Fig. 4. Logit of occupancy probability versus time index.

where β_0 is the intercept. β denotes the coefficient vector. x_c represents the vector of covariates and Y is the response variable.

In this application, the response variable is $y(k)$ and there are two covariates. Note that building occupants' behavior is strongly dependent on time of the day. For instance, people tend to stay at home during the evening, and be away from home during the day. Thus, we select the time index h that corresponds to $y(k)$ as the first covariate. Suppose there are H time intervals in a day, then the time index h represents the h th time interval of the day. The relationship between h and k is formulated as:

$$h = \begin{cases} H, & \text{mod}(k, H) = 0 \\ \text{mod}(k, H), & \text{mod}(k, H) < H \end{cases} \tag{6}$$

$y(k - 1)$ is selected as the second covariate because the occupancy state at time interval k is highly correlated with the occupancy state at time interval $k - 1$. We extend the conventional logistic regression model by adding change-points of time index as additional covariates to model the nonlinearity of the logit function $\text{logit}(p(x_c))$. The proposed occupancy prediction model can be formulated as follows:

$$g(h, y(k - 1)) \triangleq \beta_0 + \beta_1 h + \beta_2 y(k - 1) + \sum_{i=1}^p \beta_{i+2} (h - h_i)_+ \tag{7}$$

$$P(y(k) = 1 | h, y(k - 1)) = \frac{e^{g(h, y(k-1))}}{1 + e^{g(h, y(k-1))}} \tag{8}$$

where β_i denotes the i th coefficient. h_i represents the i th change point. p is the number of change points and $(h - h_i)_+ = \max(0, h - h_i)$.

To validate the effectiveness of the proposed model in occupancy prediction, 73 days of occupancy data are collected from a low-income residential house in San Antonio, TX [21]. The length of each time interval is 15 minutes. There are 96 time intervals in a day and $h = 1, 2, \dots, 96$. Given that the occupancy pattern of weekdays generally differs from that of weekends, the data are separated into two groups, i.e., weekdays (53 days in total) and weekends (20 days in total). For validation purpose, we only consider the occupancy prediction for weekdays. The case of weekends can be analyzed similarly. The weekday data are then divided into two sets, i.e., training dataset (30 days in

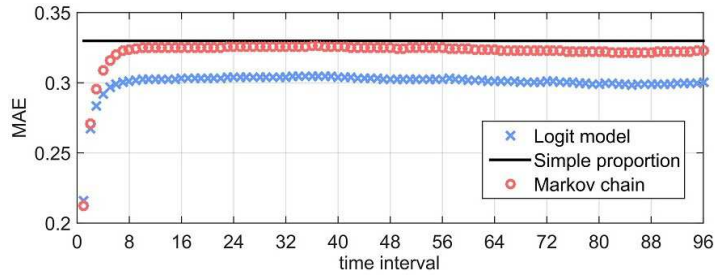

Fig. 5. MAE of the occupancy prediction methods.

total) and testing dataset (23 days in total). Fig. 3 shows the occupancy probability calculated by the simple proportion method and Fig. 4 shows the corresponding logit versus time index based on the training dataset. Three change points of the time index are introduced to fit the nonlinear logit function shown in Fig. 3. The optimal combination of change points (44, 56, and 68) and the coefficients of the model covariates are estimated with the maximum likelihood method. Detailed discussion of the maximum likelihood estimation method can be found in [22].

The implementation of multi-period model predictive control requires multi-period ahead occupancy forecasts. In this study, multi-period ahead occupancy forecasts are made by iteratively applying the one-period ahead model represented by equations (7) and (8). It should be pointed out that $y(k-1)$ is updated with the predicted occupancy probability of previous time interval during the iterative process. We conduct the rolling forecast of occupancy states from one time interval ahead to 96 time intervals (one day) ahead prediction on the testing dataset. The rolling forecast approach makes use of fixed windows of data to re-estimate the model parameters when new data become available. The accuracy of the forecast model is evaluated by the mean absolute error (MAE) metric:

$$\text{MAE} = \frac{\sum_{k=s}^{s+N_k-1} |P(y(k)=1) - y(k)|}{N_k} \quad (9)$$

where s is the first time interval being predicted and N_k is the number of data points in the testing dataset. As a comparison, we also carry out the same forecasts by using the simple proportion [10] and the inhomogeneous Markov chain methods [11]. Fig. 5 gives the forecast results of all the three methods. The numbers on the horizontal axis represent the corresponding time intervals ahead prediction, e.g., 10 represents ten time intervals ahead prediction. It is shown that the proposed logistic regression model with change-points generally outperforms the other two methods. In addition, for the first three time interval ahead predictions, both the new method and Markov chain perform much better than the simple proportion method.

3. Control strategy

In this section, a novel occupancy-based HVAC control strategy is developed by embedding the occupancy prediction algorithm into the MPC framework. The objective of the proposed control strategy is to minimize both electricity consumption and the expected occupants' discomfort. Compared with the existing methods, the proposed control framework allows the room temperature to exceed the predefined comfort zone when the probability of presence is very low. The key idea behind the proposed control strategy is that significant reduction in electricity consumption can be achieved by relaxing the temperature constraints when the room is not expected to be occupied.

Let us first derive the electricity consumption of a HVAC system. In the cooling season, the chiller and the supply fan are responsible for the majority of the electricity consumed by a HVAC system. The following two questions describe the relationships between the electricity consumptions of the chiller, the fan and the mass flow rate of supply air u [3,23]:

$$W_{\text{chiller}} = \frac{u C_{sh} (T_{\text{out}} - T_{\text{supply}})}{COP} \quad (10)$$

$$W_{fan} = k_{fan}u^3 \tag{11}$$

where *COP* is the coefficient of performance for the chiller and k_{fan} is the fan power constant. The proposed building HVAC control strategy is formulated as follows:

$$\begin{aligned} \min_u & \int_{t_0}^{t_0+w} W_H + \lambda P(y(t) = 1)(T_{room} - T_{desire})^2 dt \\ \text{s.t.} & \dot{\mathbf{x}} = \mathbf{A}\mathbf{x} + \mathbf{f}(\mathbf{x}, u) + \mathbf{D} \\ & u_{min} \leq u \leq u_{max} \\ & T_{min} \leq T_{room} \leq T_{max} \\ & W_H = k_{fan}u^3 + \frac{uC_{sh}(T_{out} - T_{supply})}{COP} \end{aligned} \tag{12}$$

where w denotes the prediction horizon. W_H represents the power of the HVAC system. λ denotes the penalty factor and T_{desire} is the desired room temperature. The first term in the objective function represents the electricity consumption of the HVAC system. The second term in the objective function represents the weighted expected discomfort of the building occupants. The room air temperature T_{room} and the control variable u are constrained within the predefined bounds. It should be pointed out that λ and T_{desire} are set by the building occupants according to their preferences. In fact, $\lambda P(y(t) = 1)$ in (12) can be seen as the weight put on the comfort against the electricity consumption. If the occupants care more about their comfort than the cost of electricity, then a relatively large λ should be selected. Otherwise, a smaller λ should be selected to achieve lower electricity cost.

Note that the proposed control strategy can easily satisfy customers’ needs to control the room temperature within the comfort range all the time. By setting λ to zero and replacing the room temperature bounds $[T_{min}, T_{max}]$ with the comfort zone, the proposed control strategy can be reduced to the MPC discussed in [4,7,23].

It is extremely difficult to obtain the analytical form of the optimal control strategy from the nonlinear optimization problem given above. Instead, we adopt the sequential quadratic programming (SQP) approach in [24,25] to find a numerical solution. The basic idea of SQP is using the Taylor series to transform the original nonlinear optimization problem into the quadratic programming (QP) problem and solve the QP problems iteratively until the solution converges. Details of the SQP approach can be found in [24]. In practice, the control signals of the HVAC are given in a discrete manner. Therefore, the original system is discretized by using the zero-order hold with an hourly sampling frequency, which is widely applied in building simulation studies [3,11,25]. Then the original nonlinear optimization problem is transformed into the following discrete quadratic programming problem:

$$\begin{aligned} \min_u & \sum_{n=t_0}^{t_0+N-1} \{W_H(n) + \lambda P(y(n) = 1)[T_{room}(n) - T_{desire}]^2\} \\ \text{s.t.} & \mathbf{x}(n + 1) = \mathbf{A}_d\mathbf{x}(n) + \mathbf{B}_d u(n) + \mathbf{H}_d \mathbf{D}(n) + g(T_{TS}(n), u_{TS}(n)) \\ & u_{min} \leq u(n) \leq u_{max} \\ & T_{min} \leq T_{room}(n) \leq T_{max} \\ & W_H(n) = k_{fan}\{u_{TS}(n)\}^3 + 3u_{TS}(n)^2[u(n) - u_{TS}(n)] + 3u_{TS}(n)[u(n) - u_{TS}(n)]^2 + \frac{u(n)C_{sh}(T_{out}(n) - T_{supply})}{COP} \end{aligned} \tag{13}$$

where N is the prediction horizon. A_d , B_d and H_d are the coefficient matrices for the discretized system. $T_{TS}(n)$ and $u_{TS}(n)$ are the centers of Taylor series expansion for the room temperature and control variable. $g(T_{TS}(n), u_{TS}(n))$ is the residual term. This QP problem can be solved by software packages such as YALMIP [26]. We start the computation process by setting initial values of $T_{TS}(n)$ and $u_{TS}(n)$. Then the QP problem described by equations (17)-(21) is solved iteratively until the convergence condition is met. In this study, the algorithm terminates when the change in the values of $T_{TS}(n)$ and $u_{TS}(n)$ between two iterations are less than 1%.

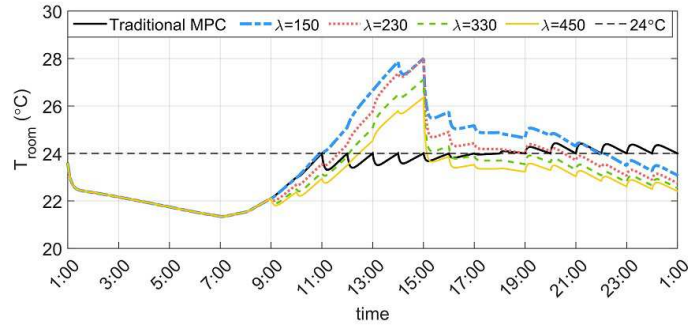

Fig. 6. The room temperature (T_{room}) under different scenarios.

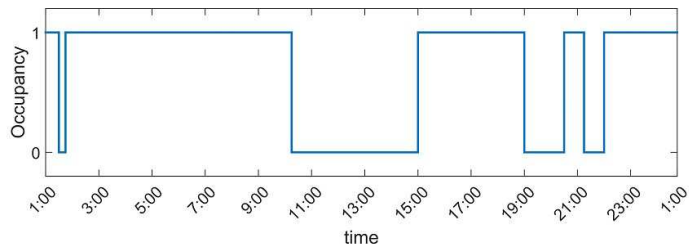

Fig. 7. Occupancy data of the first day in the testing dataset.

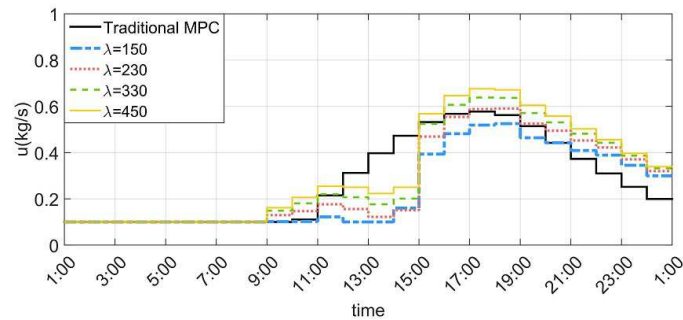

Fig. 8. The control variable (u) under different scenarios.

4. Simulation results and discussion

4.1. Simulation results

To validate the proposed control strategy, numerical simulations are carried out on the test building and the occupancy dataset discussed in Section 2. The comfort zone is set to be $[20^{\circ}\text{C}, 24^{\circ}\text{C}]$ and the room temperature is constrained within $[18^{\circ}\text{C}, 28^{\circ}\text{C}]$. The desired temperature is chosen as 22°C .

A comprehensive performance comparison is conducted between the proposed occupancy-based HVAC control and the traditional MPC algorithm. Note that both the proposed control strategy and the traditional MPC algorithm can be categorized as receding horizon control strategies. In other words, although an optimal trajectory of control variables is determined at time t for horizon $[t, t + w]$, only the first step of the control strategy is implemented. In the MPC framework, the occupancy prediction horizon keeps being shifted forward and updated control strategies keep being generated. Fig. 6, 7 and 8 depict the simulation results with the occupancy data of the first day. It can be

Table 1. Performance comparison

	MPC	$\lambda = 150$	$\lambda = 230$	$\lambda = 330$	$\lambda = 450$
DI-I	4349	4737	2745	1681	1092
DI-II	123.7	365.4	122.2	37.6	14.0
Average power [Watt]	1807	1447	1660	1841	1984

seen from Fig. 6 that the room temperature under the traditional MPC scenario is tightly controlled within the given comfort zone regardless of the building occupancy state. On the contrary, the room temperature under the proposed control strategy can exceed the upper bound of the comfort zone during periods when the probability of the building being occupied is very low. The penalty factor λ determines the optimal trade-off between energy efficiency and comfort. A building occupant who cares more about energy efficiency will select a smaller λ . As shown in Fig 6, this allows the temperature to exceed the upper bound of the comfort zone even when the building is expected to be occupied. As λ increases, more weight is put on occupants’ comfort and the electricity consumption of the HVAC system also increases.

To quantify the improvement of the proposed building HVAC control strategy over the traditional MPC, two discomfort indices are introduced as follows:

Discomfort index I (DI-I):

$$DI-I = \sum_{k=s}^{s+K-1} y(k)(T_{room}(k) - T_{desire})^2 \tag{14}$$

Discomfort index II (DI-II):

$$DI-II = \sum_{k=s}^{s+K-1} y(k) \Delta Dis(k), \tag{15}$$

$$\Delta Dis(k) = \begin{cases} T_{room}(k) - 24, & T_{room}(k) > 24 \\ 20 - T_{room}(k), & T_{room}(k) < 20 \\ 0, & else \end{cases}$$

where s is the first time interval in the testing period and K is the total number of time intervals in the testing period. DI-I and DI-II are two discomfort indices for the building occupants. In order to quantify the energy efficiency of the two control strategies, the average power consumptions by the HVAC system are calculated. The performance metrics of the traditional MPC and the proposed control strategy with different penalty factors are shown in Table 1. As the penalty factor for discomfort λ increases, the discomfort indices decrease and the electricity consumption increases. The proposed building HVAC control with real-time occupancy prediction clearly outperforms the traditional MPC algorithm. By setting λ at around 230, the proposed algorithm not only saves more than 8% of electric energy but also makes the building occupants more comfortable.

4.2. Discussion

Most of the existing HVAC control systems do not consider occupancy information. In this work, we propose a novel control strategy that incorporates the logistic regression based occupancy prediction into the MPC framework. The simulation results show that, by adopting the proposed control strategy, the electricity consumption of HVAC system can be reduced by 8%. Moreover, the overall comfort for the building occupants can also be improved by selecting an appropriate penalty factor.

5. Conclusions

A novel energy saving control strategy for building HVAC system is proposed by embedding the occupancy prediction algorithm into the MPC framework. A logistic regression model with change-points is proposed to forecast

the building occupancy state. The proposed forecasting algorithm outperforms the simple proportion method and the Markov Chain algorithm. Numerical simulations are carried out to investigate the effectiveness of the proposed control strategy. The simulation results show that the real-time occupancy based building HVAC control algorithm not only improves the building occupants' comfort level but also reduces the electricity consumption.

Acknowledgements

The authors would like to thank Dr. Bing Dong from UTSA for sharing residential building occupancy data. This work was supported by National Science Foundation (NSF) under award #1637258 and Department of Energy (DOE) under award #DE-OE0000840.

References

- [1] Sisson W, van-Aerschot C, Kornevall C, Cowe R, Bridoux D, Bonnaire TB, Fritz J. Energy efficiency in buildings: Transforming the market. Switzerland: World Business Council for Sustainable Development (WBCSD). 2009.
- [2] Building energy data book of DOE; 2011. URL: <http://buildingsdatabook.eren.doe.gov/>.
- [3] Maasoumy M, Sangiovanni-Vincentelli A. Total and peak energy consumption minimization of building hvac systems using model predictive control. *IEEE Design & Test of Computers*. 2012 Aug 1;29(4).
- [4] Avci M, Erkok M, Rahmani A, Asfour S. Model predictive HVAC load control in buildings using real-time electricity pricing. *Energy and Buildings*. 2013 May 31;60:199-209.
- [5] Zhang Y, Hanby VI. Model-based control of renewable energy systems in buildings. *HVAC&R Research*. 2006 Jul 1;12(S1):739-60.
- [6] Yu N, Wei T, Zhu Q. From passive demand response to proactive demand participation. In2015 IEEE International Conference on Automation Science and Engineering (CASE) 2015 Aug 24 (pp. 1300-1306). IEEE.
- [7] Aswani A, Master N, Taneja J, Culler D, Tomlin C. Reducing transient and steady state electricity consumption in HVAC using learning-based model-predictive control. *Proceedings of the IEEE*. 2012 Jan;100(1):240-53.
- [8] Oldewurtel F, Parisio A, Jones CN, Gyalistras D, Gwerder M, Stauch V, Lehmann B, Morari M. Use of model predictive control and weather forecasts for energy efficient building climate control. *Energy and Buildings*. 2012 Feb 29;45:15-27.
- [9] Dong B, Lam KP. A real-time model predictive control for building heating and cooling systems based on the occupancy behavior pattern detection and local weather forecasting. In*Building Simulation 2014 Feb 1 (Vol. 7, No. 1, pp. 89-106)*. Springer Berlin Heidelberg.
- [10] Majumdar A, Setter JL, Dobbs JR, Hency BM, Albonesi DH. Energy-comfort optimization using discomfort history and probabilistic occupancy prediction. In*Green Computing Conference (IGCC), 2014 International 2014 Nov 3 (pp. 1-10)*. IEEE.
- [11] Dobbs JR, Hency BM. Predictive HVAC control using a Markov occupancy model. In2014 American Control Conference 2014 Jun 4 (pp. 1057-1062). IEEE.
- [12] Oldewurtel F, Sturzenegger D, Morari M. Importance of occupancy information for building climate control. *Applied energy*. 2013 Jan 31;101:521-32.
- [13] McQuiston FC, Parker JD. Heating, ventilating, and air conditioning: analysis and design, 6th Edition. New York, NY: John Wiley & Sons; 2004.
- [14] Maasoumy M, Pinto A, Sangiovanni-Vincentelli A. Model-based hierarchical optimal control design for HVAC systems. In*ASME 2011 Dynamic Systems and Control Conference and Bath/ASME Symposium on Fluid Power and Motion Control 2011 Jan 1 (pp. 271-278)*. American Society of Mechanical Engineers.
- [15] Goyal S, Barooah P. A method for model-reduction of non-linear thermal dynamics of multi-zone buildings. *Energy and Buildings*. 2012 Apr 30;47:332-40.
- [16] Fraisse G, Viardot C, Lafabrie O, Achard G. Development of a simplified and accurate building model based on electrical analogy. *Energy and buildings*. 2002 Nov 30;34(10):1017-31.
- [17] Yadav AK, Chandel SS. Solar radiation prediction using Artificial Neural Network techniques: A review. *Renewable and Sustainable Energy Reviews*. 2014 May 31;33:772-81.
- [18] Energyplus. 2016. URL: <https://energyplus.net/>.
- [19] Weather Data. 2016. URL: <https://energyplus.net/weather>.
- [20] Hosmer Jr DW, Lemeshow S, Sturdivant RX. *Sturdivant. Applied logistic regression*. New York: John Wiley & Sons; 2013.
- [21] Dong B, Li Z, Mcfadden G. An investigation on energy-related occupancy behavior for low-income residential buildings. *Science and Technology for the Built Environment*. 2015 Aug 18;21(6):892-901.
- [22] Pampel FC. *Logistic regression: A primer*. Thousand Oaks, CA: Sage; 2000.
- [23] Kelman A, Ma Y, Borrelli F. Analysis of local optima in predictive control for energy efficient buildings. *Journal of Building Performance Simulation*. 2013 May 1;6(3):236-55.
- [24] Boggs PT, Tolle JW. Sequential quadratic programming. *Acta numerica*. 1995;4:1-51.
- [25] Wei T, Zhu Q, Yu N. Proactive Demand Participation of Smart Buildings in Smart Grid. *IEEE Transactions on Computers*. 2016 May 1;65(5):1392-406.
- [26] Lofberg J. YALMIP: A toolbox for modeling and optimization in MATLAB. In*Computer Aided Control Systems Design, 2004 IEEE International Symposium on 2004 Sep 4 (pp. 284-289)*. IEEE.