

HoORaYs: High-order Optimization of Rating Distance for Recommender Systems

Jingwei Xu
State Key Laboratory for Novel
Software Technology
China 210023
jingwei.xu@smail.nju.edu.cn

Yuan Yao*
State Key Laboratory for Novel
Software Technology
China 210023
y.yao@nju.edu.cn

Hanghang Tong
Arizona State University
Phoenix, Arizona
hanghang.tong@asu.edu

Xianping Tao
State Key Laboratory for Novel
Software Technology
China 210023
txp@nju.edu.cn

Jian Lu
State Key Laboratory for Novel
Software Technology
China 210023
lj@nju.edu.cn

ABSTRACT

Latent factor models have become a prevalent method in recommender systems, to predict users' preference on items based on the historical user feedback. Most of the existing methods, explicitly or implicitly, are built upon the *first-order rating distance* principle, which aims to minimize the difference between the estimated and real ratings. In this paper, we generalize such first-order rating distance principle and propose a new latent factor model (HoORaYs) for recommender systems. The core idea of the proposed method is to explore *high-order rating distance*, which aims to minimize not only (i) the difference between the estimated and real ratings of the same (user, item) pair (i.e., the first-order rating distance), but also (ii) the difference between the estimated and real rating difference of the same user across different items (i.e., the second-order rating distance). We formulate it as a regularized optimization problem, and propose an effective and scalable algorithm to solve it. Our analysis from the geometry and Bayesian perspectives indicate that by exploring the high-order rating distance, it helps to reduce the *variance* of the estimator, which in turns leads to better generalization performance (e.g., smaller prediction error). We evaluate the proposed method on four real-world data sets, two with explicit user feedback and the other two with implicit user feedback. Experimental results show that the proposed method consistently outperforms the state-of-the-art methods in terms of the prediction accuracy.

CCS CONCEPTS

•Information systems → Information systems applications;
Collaborative filtering; Data mining;

KEYWORDS

High-order distance, recommender systems, latent factor model, collaborative filtering

1 INTRODUCTION

In recent years, researchers have devoted great efforts to the development of recommender systems in many real-world applications [4, 6, 11]. The key task of recommender systems is to predict the users' preference on items. Collaborative filtering (CF) methods and content-based methods have been widely used to achieve this task. For example, matrix factorization [11] takes ratings as input and outputs the latent vectors for users and items; it becomes a popular base for recommender systems, largely due to its great success at the Netflix Prize. To further improve the recommendation accuracy, Wang et al. [20] propose the collaborative topic regression (CTR) rating model to incorporate item content; Ma et al. [12] model social trust (Sorec) by incorporating social relationships and ratings. The combination of CTR and Sorec is also explored [2, 17].

A line of existing work has focused on employing different types of data (e.g., ratings, item content, social relationships, etc.) so as to make more informed and accurate recommendations. In this work, we focus on an orthogonal line work, i.e., the optimization formulation aspect.

From the optimization viewpoint, most of the existing methods, explicitly or implicitly, are built upon the *first-order rating distance* principle. That is, these methods seek for an 'optimal' latent representations for users and items, which minimize the differences between the estimated and real ratings of the *same* (user, item) pair. Conceptually, minimizing the first-order distance (between the real rating to estimated rating) can be viewed as a self-calibration process. However, the solution space of the optimization problem could be large, especially when the available user feedback information is sparse, which might result in a *biased* estimator for the latent vectors of users and items.

In this paper, we generalize the first-order distance principle and propose to leverage the high-order distance to improve the recommendation performance. The core idea of the proposed method is to explore *high-order rating distance*, which aims to minimize not only (i) the difference between the estimated and real ratings of the

Permission to make digital or hard copies of all or part of this work for personal or classroom use is granted without fee provided that copies are not made or distributed for profit or commercial advantage and that copies bear this notice and the full citation on the first page. Copyrights for components of this work owned by others than ACM must be honored. Abstracting with credit is permitted. To copy otherwise, or republish, to post on servers or to redistribute to lists, requires prior specific permission and/or a fee. Request permissions from permissions@acm.org.

KDD '17, August 13–17, 2017, Halifax, NS, Canada

© 2017 ACM. 978-1-4503-4887-4/17/08...\$15.00

DOI: 10.1145/3097983.3098019

same (user, item) pair (i.e., the first-order rating distance), but also (ii) the difference between the estimated and real rating difference of the same user across different items (i.e., the second-order rating distance). We hypothesize that by exploring high-order distance, it will help shrink the solution space of the corresponding optimization problem. By doing so, the *variance* of the estimator (i.e., the latent representations of users and items) could be mitigated, which will in turn lead to better generalization performance (e.g., a smaller prediction error).

The main contributions of this paper include:

- **New Model and Algorithm** that embrace the high-order rating distance in the latent factor methods for recommender systems. The proposed model HoORAYs can handle both explicit and implicit user feedback, as well as the case when content information is available. The proposed algorithm is able to find local optima with a linear time complexity.
- **Analysis** from both the geometric perspective and the Bayesian perspective for the proposed model, which provides key insight on how the high-order distance reduces the variance, and how to generalize the high-order distance based optimization to other recommendation models.
- **Experimental evaluations** on four real-world data sets showing the effectiveness of the proposed method. For example, the proposed method outperforms the best competitors by up to 24.3% improvement in terms of the prediction accuracy.

The rest of the paper is organized as follows. In Section 2, we present the problem statement. In Section 3, we describe the proposed model with the geometric interpretation, Bayesian interpretation, and algorithm analysis. In Section 4, we present the experimental results. In Section 5, we review the related work. Finally, we conclude the paper in Section 6.

2 PROBLEM STATEMENT

In this section, we provide the problem statement and some background knowledge of our proposed model.

2.1 The Recommendation Problem

In recommender systems, the two kinds of fundamental elements are users and items. We assume there are M users and N items in the recommender system. We denote the latent vectors for users as $U = \{u_i\}_{i=1}^m$, and the latent vectors for items as $V = \{v_j\}_{j=1}^n$. The length of these latent vectors is K . The observed ratings are usually denoted as $R = \{r_{ij} | r_{ij} \in [1, r_{max}]\}$, where r_{ij} represents the rating that user i gives to item j , and the value r_{max} is the scale of rating in the target recommender system (e.g., 5 stars on *MovieLens*).

Based on the above notations, we define the target problem as follows

PROBLEM 1. *The Recommendation Problem*

Given: (1) the set of existing ratings R from users to items, (2) a user i , and (3) an item j ;

Find: the estimated rating \hat{r}_{ij} from user i to item j .

As we can see from the definition, the input of our problem includes the existing ratings. Our focus is on the optimization aspect

instead of employing more types of data, although the proposed method can be similarly applied when more types data are available. The goal is to predict the unobserved ratings from users to items, and we can directly obtain the ratings as long as we have learned the latent vectors U and V .

2.2 Latent Factor Models: Matrix Factorization

In recent years, matrix factorization based collaborative filtering [11] becomes one of the most popular methods to solve the recommendation problem. In the view of matrix factorization, the users and items could be represented by factors in the same latent factor space. For example, user i is represented by a latent factor vector u_i , and item j is represented by a latent factor vector v_j . So we predict the rating that user i gives to item j with the inner product of the two corresponding latent factor vectors

$$\hat{r}_{ij} = u_i^T v_j \quad (1)$$

We use the observed ratings to learn the latent factor vectors. Commonly, we minimize the following optimization function

$$\min_{U^*, V^*} \sum_{r_{ij} \in R} (r_{ij} - u_i^T v_j)^2 \quad (2)$$

where square loss is used as the loss function, and R is the set of the observed ratings.

2.3 Model Variance Reduction

From statistical learning perspective, a good estimator (e.g., latent vectors in our recommendation problem) should have small prediction errors (*PE*) on both training and the new data. With the bias-variance decomposition [5], the expected prediction error is the sum of three terms: the *irreducible errors*, *Bias*, and *Variance*

$$PE = \sigma^2 + Bias^2 + Variance \quad (3)$$

It is well known that the local curvature can be picked up to fit the training data when the model becomes more complex. However, such a complex model suffers from the high *variance*, and hence to a high *PE* when estimating on the new data (overfitting). To deal with the overfitting in Eq. (1), researchers added ridge constraints (i.e., L2-regularization) on the parameters u_i and v_j by controlling their sum of squares, so that the original unconstrained optimization problem becomes

$$\text{minimize} \sum_{r_{ij} \in R} (r_{ij} - u_i^T v_j)^2 \quad \text{s.t.} \quad \sum_{i=1}^m (u_i)^2 \leq t_u, \quad \sum_{j=1}^n (v_j)^2 \leq t_v \quad (4)$$

where $t_u > 0$ and $t_v > 0$. The above optimization problem can be re-written as

$$\mathcal{L} = \sum_{r_{ij} \in R} (r_{ij} - u_i^T v_j)^2 + \lambda_u \sum_{i=1}^m \|u_i\|^2 + \lambda_v \sum_{j=1}^n \|v_j\|^2 \quad (5)$$

where λ_u and λ_v are the parameters to control the L2 regularization terms. With the proper λ_u and λ_v , Eq. (5) balances *bias* and *variance* to reach the lower *PE*.

3 HIGH-ORDER OPTIMIZATION OF RATING DISTANCE

In this section, we describe the proposed HoORAYs model (Subsection 3.1). Then, we analyze why the proposed model can reduce the *variance* of the estimator from two different perspectives, including geometric interpretation (Subsection 3.2) and Bayesian interpretation (Subsection 3.3). Finally, we present a brief algorithm analysis in terms of its optimality and complexity (Subsection 3.4).

3.1 The HoORAYs Model

The core idea of HoORAYs is to use high-order rating distance to reduce the *variance* of the estimator (i.e., the latent factors for users and items) by shrinking the solution space of the optimization problem in Eq. (4). The intuition is as follows. By optimizing the first-order distance, we basically want to find a good estimator which matches a user's *preference* on each of the observed *items*. By introducing the additional high-order distance, we require the learnt latent factors to *also* capture the subtle *preference difference* of a user across different *item pairs*.

In particular, the error between the real rating r_{ij} and the estimated rating \hat{r}_{ij} in Eq. (4) can be treated as the distance between two ratings. In addition the rating distance of $\langle r_{ij}, \hat{r}_{ij} \rangle$ pair, other rating errors from different kinds of pairs (e.g., $\langle r_{ij'}, \hat{r}_{ij} \rangle$, $\langle r_{ij'}, r_{ij} \rangle$, and so on) can also be measured as rating distances. These rating distances have their own meaning in the context of recommender systems. For example, the distance between $r_{ij'}$ and r_{ij} (denoted by D) means the real difference between item j and item j' under user i ; the distance between $r_{ij'}$ and \hat{r}_{ij} (denoted by \hat{D}) means the estimated difference between item j and item j' under user i after estimating \hat{r}_{ij} . Furthermore, when $r_{ij'}$ is fixed for both D and \hat{D} , we can measure the distance between D and \hat{D} . The error between D and \hat{D} reflects the accuracy of learned latent vectors of user i and item j . This error is the distance between two rating distances, and we call this distance of distance as second-order rating distance.

As we can see, both first-order and second-order distances reflect the learned latent vectors of user/items. If we add second-order rating distance to the optimization problem in Eq. (4) as an additional constraint, we could further reduce the *variance* of the latent vectors of users/items in recommender systems. The optimization problem of our proposed HoORAYs is written as below

$$\begin{aligned} & \text{minimize} \sum_{r_{ij} \in R} (r_{ij} - u_i^T v_j)^2 \\ & \text{s.t.} \sum_{i=1}^m (u_i)^2 \leq t_u, \sum_{j=1}^n (v_j)^2 \leq t_v \\ & \sum_{r_{ij}} \sum_{r_{i'j'}} I_{ijj'j'} (\sigma(u_i^T v_j, r_{ij}) - \sigma(r_{ij}, r_{i'j'}))^2 = 0 \end{aligned} \quad (6)$$

where $\sigma(x, y) = 1/(1 + e^{-(x-y)})$, and $I_{ijj'j'} = 1$ if ratings r_{ij} and $r_{i'j'}$ exist with $i' = i \wedge j' \neq j \vee i' \neq i \wedge j' = j$. The optimization

problem with second-order rating distance constraint can be re-written as follow

$$\begin{aligned} & \text{argmin}_{U^*, V^*} \sum_{r_{ij}} (r_{ij} - u_i^T v_j)^2 + \lambda_u \sum_{i=1}^m \|u_i\|^2 + \lambda_v \sum_{j=1}^n \|v_j\|^2 \\ & + \lambda_d \sum_{r_{ij}} \sum_{r_{i'j'}} I_{ijj'j'} (\sigma(u_i^T v_j, r_{ij}) - \sigma(r_{ij}, r_{i'j'}))^2 \end{aligned} \quad (7)$$

where λ_d is the parameter to control the effect of second-order rating distance.

Speed Gear. Since the complexity of second-order distance in Eq. (7) is roughly $O(|R|(|\bar{R}_u| + |\bar{R}_v|))$, we propose to speedup the model learning process based on two key observations: (i) the rating scale is usually small for recommender systems (e.g., 1-5 stars), and (ii) the contributions of different ratings from other users/items are equal to each other if they share the same rating value. Hence, the loss function in Eq. (7) could be re-written as

$$\begin{aligned} & \text{argmin}_{U^*, V^*} \sum_{r_{ij}} (r_{ij} - u_i^T v_j)^2 + \lambda_u \sum_{i=1}^m \|u_i\|^2 + \lambda_v \sum_{j=1}^n \|v_j\|^2 \\ & + \lambda_d \sum_{r_{ij}} \sum_{r=1}^{r_{max}} |\Omega_{r_{ij}, r}| (\sigma(u_i^T v_j, r) - \sigma(r_{ij}, r))^2 \end{aligned} \quad (8)$$

where r_{max} is the maximal rating value (e.g., $r_{max} = 5$ in *MovieLens*), and $|\Omega_{r_{ij}, r}|$ is the total number of ratings that the user i rated to other items with value r or the item j received from other users with value r .

Update Rules. We use stochastic gradient descent to optimize Eq. (8). In detail, we alternatively optimize U, V in each iteration. In each iteration, we take the partial derivatives of Eq. (8) with respect to u_i and v_j , which lead to the following update rules

$$\begin{aligned} u_i & \leftarrow -\lambda_u u_i + (r_{ij} - u_i^T v_j) v_j \\ & + \lambda_d \sum_{r=1}^{r_{max}} |\Omega_{r_{ij}, r}| (\sigma(r_{ij}, r) \sigma(u_i^T v_j, r) (1 - \sigma(u_i^T v_j, r)) v_j \\ & - \sigma(u_i^T v_j, r)^2 (1 - \sigma(u_i^T v_j, r)) v_j) \end{aligned} \quad (9)$$

$$\begin{aligned} v_j & \leftarrow -\lambda_v v_j + (r_{ij} - u_i^T v_j) u_i \\ & + \lambda_d \sum_{r=1}^{r_{max}} |\Omega_{r_{ij}, r}| (\sigma(r_{ij}, r) \sigma(u_i^T v_j, r) (1 - \sigma(u_i^T v_j, r)) u_i \\ & - \sigma(u_i^T v_j, r)^2 (1 - \sigma(u_i^T v_j, r)) u_i) \end{aligned} \quad (10)$$

We summarize our fast learning algorithm in Alg. 1, where α is the learning rate, ∇ is the partial derivative operator, and we use stochastic gradient descent method to learn the parameters.

3.2 Geometric Interpretation of HoORAYs

Here we present the geometric interpretation of the proposed HoORAYs. By adding the constraint of second-order rating distance to the optimization problem in Eq. (4), the solution space to U and V can be further shrunk, which leads to the decrease on *variance*.

The illustrative example in Fig. 1 shows how the constraint of second-order rating distance could shrink the original solution space. Suppose that the latent factor space is 2-dimensional, and each user/item has its place, which is presented as the latent vector in the space. In Fig. 1(a), taking user i and item j for example

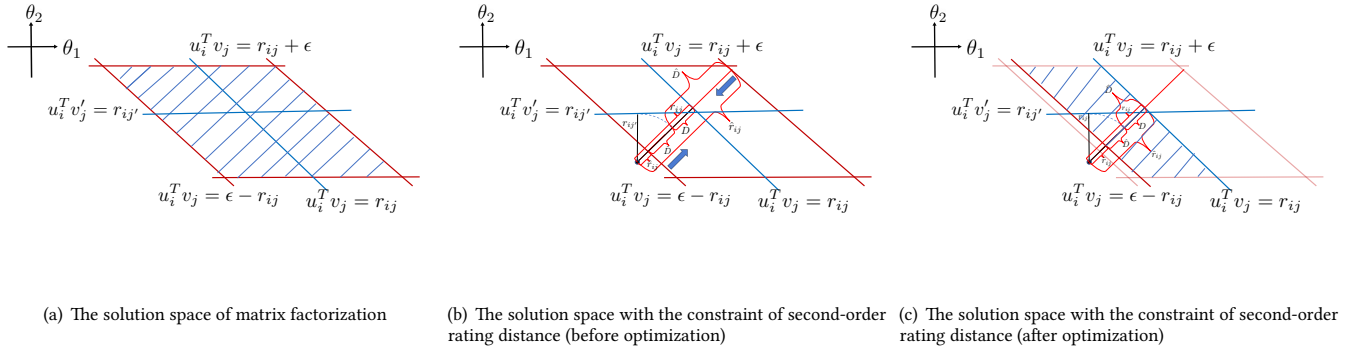

Figure 1: The illustrative example of applying the constraint of second-order rating distance to matrix factorization. We can see that second-order distance further shrinks the solution space, which means to reduce *variance* of prediction error for the optimization problem. Notice that, the second-order distance will also shrink the solution space on the other side, for clarify, we do not indicate that in the figure.

Algorithm 1: Learning HoORAYs

Input: the set of observed ratings R , and the maximal rating scale r_{max}

Output: latent vectors of users U , latent vectors of items V

```

1 initialize  $U, V$ 
2 repeat
3   for  $r_{ij} \in R$  do
4     for  $r \leftarrow 1, \dots, r_{max}$  do
5       for  $f \leftarrow 1, \dots, k$  do
6         update  $u_{i,f} \leftarrow u_{i,f} - \alpha \nabla u_{i,f}$  as defined in Eq. (9)
7         update  $v_{j,f} \leftarrow v_{j,f} - \alpha \nabla v_{j,f}$  as defined in Eq. (10)
8 until convergence;
9 return  $U^*, V^*$ 

```

and by assuming that v_j and r_{ij} are given, we want to find u_i by first-order rating distance (e.g., matrix factorization). Ideally, $u_i^T v_j = r_{ij}$ exists for the perfect u_i , and this line could be plotted in the space. As shown in Fig. 1(a), any point in this line is a solution to u_i , and all points satisfy the best condition to r_{ij} . Then, we allow the error to u_i , e.g., $|u_i^T v_j - r_{ij}| < \epsilon$. With the two paralleled lines $u_i^T v_j = r_{ij} + \epsilon$ and $u_i^T v_j = r_{ij} - \epsilon$ (two red lines in Fig. 1(a)), any point inside the two bounded lines is a solution that satisfies to the error ϵ . Now, we consider another item j' with the given $v_{j'}$ into the space, and the solution space of u_i is then bounded by the four red lines in the Fig. 1(a). In Fig. 1(b), the black point is the origin of the latent factor space, and the length of perpendicular distance from origin to line $u_i^T v_j = r_{ij}$ is r_{ij} when u_i is normalized. $r_{ij'}$, denoted as a black line segment, can also be measured in the space. After coinciding line segment $r_{ij'}$ to line segment r_{ij} , several second-order distances appear. In Fig. 1(b), the second-order distance between r_{ij} and $r_{ij'}$ is denoted as D . Based on the two worst estimated \hat{r}_{ij} bounded by ϵ , we could point out

two second-order distances between \hat{r}_{ij} and $r_{ij'}$ as \hat{D} in Fig. 1(b). By the constraint of $|\hat{D} - D|^2 = 0$, the error bounds would shrink from both sides. Ideally, as the optimization problem in Eq. (6) reaches the optima, the shaded area will be compressed by the constraint of second-order rating distance. Shrinking the solution space reduces the *variance* (e.g., almost half of original solution space is shrunk in Fig. 1(c)), and might reduce the prediction error (*PE*) of the rating model in Eq. (1).

3.3 Bayesian Interpretation of HoORAYs

In addition to the geometric interpretation, we present our proposed HoORAYs from Bayesian perspective. Minh et al. [14] presented a probabilistic model for matrix factorization. In probabilistic matrix factorization, they assumed that ratings are generated by a specific generative process. In order to leverage information from content (e.g., reviews, tags), researchers used topic modeling approaches to extract latent topics from items. Collaborative topic regression (CTR) model was proposed by Wang et al. [20] to deal with recommendation problem by considering the merit of both probabilistic topic modeling and collaborative filtering.

The proposed HoORAYs can apply to both MF and CTR. Take CTR model as the rating model, The graphical model of HoORAYs is shown in Fig. 2. We treat the constraint of second-order distance as an observed random variable after observing the rating. Next, instead of simply using the distance between the real r_{ij} and estimated \hat{r}_{ij} as the optimization target in CTR, we optimize over the second-order distance $d_{ijj'j'}$ which is the distance between the real rating distance (between r_{ij} and $r_{ij'}$) and the estimated rating distance (between \hat{r}_{ij} and $r_{ij'}$). The generative process of HoORAYs is as follows

- For each user i , draw the latent vector $u_i \sim \mathcal{N}(0, \lambda_u^{-1} \mathbf{I}_K)$
- For each item j
 - Draw topic proportions $\theta_j \sim \text{Dirichlet}(\alpha)$
 - Draw the latent offset $\epsilon_j \sim \mathcal{N}(0, \lambda_v^{-1} \mathbf{I}_K)$ and set the item latent vector as $v_j = \epsilon_j + \theta_j$
 - For each word w_{jn_w} ,

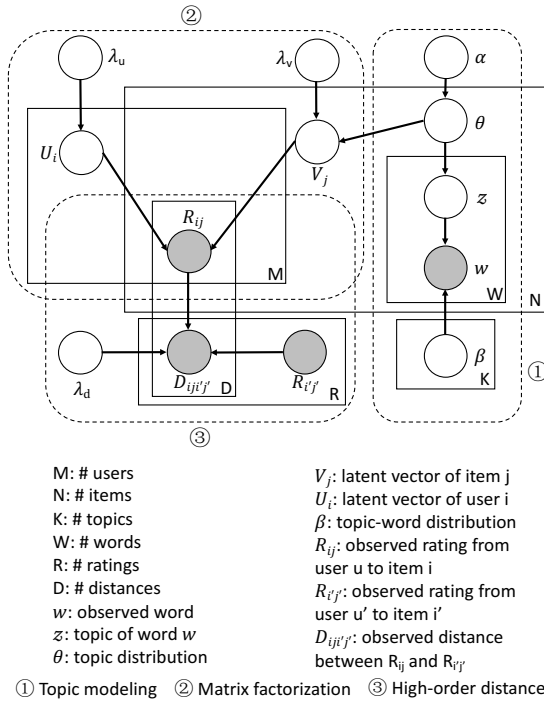

Figure 2: The probabilistic graphical model of HoORAYs.

- * Draw topic assignment $z_{jn_w} \sim \text{Mult}(\theta_j)$
- * Draw word $w_{jn_w} \sim \text{Mult}(\beta_{z_{jn_w}})$
- For each pair of user and item, draw the rating

$$r_{ij} \sim \mathcal{N}(u_i^T v_j, c_{ij}^{-1})$$
- For each second-order rating distance of r_{ij} vs. $r_{i'j'}$ ($i' = i \wedge j' \neq j \vee i' \neq i \wedge j' = j$), draw the distance

$$d_{ij i'j'} \sim \mathcal{N}(\sigma(u_i^T v_j, r_{i'j'}), \lambda_d^{-1})$$

where $\mathcal{N}(x|\mu, \sigma^2)$ is the Gaussian distribution with mean μ and variance σ^2 , \mathbf{I}_K is the $K \times K$ identity matrix, the function g is the sigmoid function where $\sigma(x, y) = 1/(1 + e^{-(x-y)})$, and c_{ij} is the confidence parameter for the rating r_{ij} , which is introduced by Wang et al. [20] to solve the *one-class* collaborative filtering problem with implicit feedback. Specifically, we set c_{ij} a higher value if $r_{ij} = 1$, and we give c_{ij} a lower value if $r_{ij} = 0$.

The conditional distribution over the observed high-order distance is

$$P(D|R, U, V, \lambda_d^{-1}) = \prod_i^m \prod_j^n \prod_{i'}^m \prod_{j'}^n \mathcal{N}(\sigma(u_i^T v_j, r_{i'j'}), \lambda_d^{-1})^{I_{ij i'j'}} \quad (11)$$

where $I_{ij i'j'} = 1$ if ratings r_{ij} and $r_{i'j'}$ exist with $i' = i \wedge j' \neq j \vee i' \neq i \wedge j' = j$. Then, we have the following equation for the posterior probability of the latent vectors of HoORAYs by the Bayesian inference

$$p(U, V|D, R, C, \lambda_d, \lambda_u, \lambda_v) \propto p(D|R, \lambda_d)p(R|U, V, C)p(U|\lambda_u)p(V|\lambda_v) \quad (12)$$

Given the topic parameter β , computing the full posterior of u_i , v_j , and θ_j directly is intractable. Here, we develop an EM-style

algorithm to learn the maximum a posteriori estimates. Notice that, maximizing the posterior in Eq. (12) is equivalent to maximizing the complete log likelihood of θ, U, V, R and D , given $\lambda_u, \lambda_v, \lambda_d, C$, and β .

$$\begin{aligned} \mathcal{L}^* = & -\frac{\lambda_u}{2} \sum_{i=1}^m u_i^T u_i - \frac{\lambda_v}{2} \sum_{j=1}^n (v_j - \theta_j)^T (v_j - \theta_j) \\ & + \sum_{j=1}^n \sum_{n_w=1}^W \log(\sum_k \theta_{jk} \beta_{k, w_{jn_w}}) \\ & - \frac{\lambda_d}{2} \sum_{r_{ij}} \sum_{r=1}^{r_{max}} |\Omega_{r_{ij}, r}| (\sigma(r_{ij}, r) - \sigma(u_i^T v_j, r))^2 \\ & - \sum_{r_{ij}} \frac{c_{ij}}{2} (r_{ij} - u_i^T v_j)^2 \end{aligned} \quad (13)$$

where r_{max} is the maximal rating value (e.g., $r_{max} = 5$ in *MovieLens*), and $|\Omega_{r_{ij}, r}|$ is the total number of ratings that the user i rated to other items with value r or the item j received from other users with value r .

We use stochastic gradient ascent to optimize Eq. (13). In detail, we iteratively optimize U, V , and the topic proportions θ . Given the current estimate of θ_j , we could find optima of U and V via similar equations to Eq. (9) and Eq. (10). Given the current U and V , we update the topic proportions θ as follows. We first define $q(z_{jn_w} = k) = \phi_{jn_w k}$, and then separate the items that contain θ_j and apply Jensen's inequality as follows

$$\begin{aligned} \mathcal{L}(\theta_j) \geq & -\frac{\lambda_v}{2} (v_j - \theta_j)^T (v_j - \theta_j) \\ & + \sum_{n_w=1}^W \sum_k \phi_{jn_w k} (\log \theta_{jk} \beta_{k, w_{jn_w}} - \log \phi_{jn_w k}) \\ = & \mathcal{L}(\theta_j, \Phi_j) \end{aligned} \quad (14)$$

Let $\Phi_j = (\phi_{jn_w k})_{n_w=1, k=1}^{W \times K}$. $\mathcal{L}(\theta_j)$ has a tight lower bound $\mathcal{L}(\theta_j, \Phi_j)$. Analytically, we cannot optimize θ_j . Hence, we use projection gradient approach to optimize the other parameters $U, V, \theta_{1:N}$, and $\phi_{1:N}$. After estimating U, V , and ϕ , we could optimize β as follows

$$\beta_{kw} \propto \sum_j \sum_{n_w} \phi_{jn_w k} [w_{jn_w} = w] \quad (15)$$

After the optimal parameters $U^*, V^*, \theta_{1:N}^*$, and β^* are learned, each rating r_{ij} can be estimated as

$$r_{ij} \approx (u_i^*)^T v_j^* \quad (16)$$

3.4 Algorithm Analysis

In this part, we analyze the effectiveness and efficiency of our algorithms.

The effectiveness of the proposed HoORAYs is summarized in Lemma 3.1. Overall, it finds local optima in the solution space of the latent vectors from users and items. The proposed optimization problem (Eq. (8)) is not convex wrt the coefficients (u_i, v_j) , and such a local minimum is acceptable in practice.

LEMMA 3.1 (Effectiveness of HoORAYs). *Fixing the ratings in R , HoORAYs finds the local minimum for the optimization problem in Eq. (8).*

Table 1: The statistics of the four data sets.

Data	<i>Lastfm</i>	<i>Delicious</i>	<i>MovieLens</i>	<i>Google Play</i>
#users	1,892	1,867	2,113	170,781
#items	17,632	69,226	10,197	104,061
#tags	11,946	53,388	13,222	N/A
#taggings	186,479	437,593	47,957	N/A
#words	N/A	N/A	N/A	10,569
#reviews	N/A	N/A	N/A	3,367,435
#ratings/hits	92,834	104,799	855,598	3,367,435
rating Scale	[1]	[1]	[0.5-5]	[1-5]

PROOF SKETCH. If we fix either the U matrix or the V matrix, the optimization problem becomes convex and the corresponding step in Alg. 1 can find the global optima. Next, based on the alternating procedure of learning parameters U and V in Alg. 1, we have that Alg. 1 finds a local minimum for the optimization problem in Eq. (8).

The time complexity of the proposed HoORAYs is summarized in Lemma 3.2. This Lemma shows that HoORAYs requires *linear time* for learning latent vectors of users and items (e.g., step 3-7 in Alg. 1); and it scales linearly wrt the number of observed ratings in the training phase (e.g., step 2-7 in Alg. 1).

LEMMA 3.2 (**Time Complexity of HoORAYs**). *Fixing the set of ratings R , and r_{max} , HoORAYs requires $O(|R|)$ time for each iteration in Alg. 1*

PROOF. For each iteration in Alg. 1, we need $O(|R|)$ time for the loop that starts from step 3. The time cost for the loop that starts from step 4 is r_{max} , and step 5-7 costs $O(k)$ time for updating parameters. Therefore, the total time cost of the iteration of step 2-7 is $O(|R| \cdot r_{max} \cdot k \cdot m)$, where m is the maximum iteration number for Alg. 1. Notice that, r_{max} , k and m are small constants, so the total time cost of Alg. 1 can be written as $O(|R|)$. \square

4 EXPERIMENTS

In this section, we present the experimental evaluations. All the experiments help us to answer the following questions:

- How accurate is the proposed method compared to the state-of-the-art methods?
- How efficient is the proposed method compared to the state-of-the-art methods? How scalable is the proposed method?
- How do the parameters affect the performance of our model?

4.1 Experimental Setup

4.1.1 *Data Sets*. In this paper, we use four real-world data sets, i.e., *Google Play*, *MovieLens*, *Lastfm*, and *Delicious*. The first data set was collected by Chen et al. [3], and the other three data sets were provided by Cantador et al. [1]. Table 1 shows the statistics of the four data sets. For the *Lastfm* and *Delicious* data, the user feedback is implicitly given by listening to a song (on *Lastfm*) and bookmarking an item (on *Delicious*), respectively. Following typical implicit feedback setting, we set the user rating as '1' if the implicit feedback is observed, and '0' otherwise. For the *MovieLens* and *Google Play* data, there are explicit ratings from users to items.

The rating scale is [0.5 ~ 5] with step 0.5 for *MovieLens* data, and [1 ~ 5] with step 1 for *Google Play* data. As for the content information, we use the aggregated review content in the first data set. We follow standard processing steps including stop-words removal, short-words removal, low-frequency words removal, high-frequency words removal, and stemming. For the other three data sets, we directly use the tag information on items as content input.

4.1.2 *Evaluation Metrics*. In this paper, we use the following four evaluation metrics. Specially, we use Root Mean Square Error (*RMSE*) and Mean Absolute Error (*MAE*) for the case of explicit feedback, and use *Recall@N* and Area Under the Curve (*AUC*) for the case of implicit feedback. In other words, *RMSE* and *MAE* are used for the *Google Play* and *MovieLens* data, and they are defined as

$$RMSE = \sqrt{\frac{\sum_{r_{ij} \in T} (\hat{r}_{ij} - r_{ij})^2}{|T|}}$$

$$MAE = \frac{\sum_{r_{ij} \in T} |\hat{r}_{ij} - r_{ij}|}{|T|}$$

where T is the set of ratings to be evaluated as the test set.

Recall@N and *AUC* are used for *Lastfm* and *Delicious*. For a given user, *Recall@N* is defined as the ratio between the number of items that the user likes in Top N ranking list, and the total number of items that the user likes; *AUC* indicates the probability that a randomly chosen observed example is ranked higher than a randomly chosen unobserved example. For these two metrics, we average them over all the users as the final result.

4.1.3 *Compared methods*. In the experiment section, we use HoORAYs to denote the proposed model that considers content information, and use HoORAYs₀ to denote the proposed model without content information. We compare our methods (HoORAYs₀ and HoORAYs) with some state-of-the-art recommendation algorithms including probabilistic matrix factorization (PMF) [14], collaborative topic regression (CTR) [20], and Bayesian personalized ranking (BPR) [18]. Note that BPR is specially designed for the implicit feedback, and we only compare with BPR in the implicit feedback case. As for parameters, the dimension of the latent vectors is set to 200 for the proposed methods and all the competitors. The reported results come from the best parameters tuned for each model. For HoORAYs₀ and HoORAYs, we set $\alpha = 0.01$, $\lambda_u = 0.1$, and $\lambda_v = 0.1$ ($\lambda_v = 0.5$ for *Google Play*), where α is the learning rate. Since λ_d is more sensitive to data, we set $\lambda_d = 0.01$ on *Google Play* and *MovieLens* data sets, $\lambda_d = 0.1$ on *Lastfm* data, and $\lambda_d = 5$ on *Delicious* data.

For all the four data sets, we randomly select 75% of the user feedback as training data, the use the remaining data as test set.

4.1.4 *Reproducibility of experiments*. All the datasets are publicly available. All the parameter settings are stated in the previous subsection. We will release the code of the proposed algorithm through the first author's website* upon the publication of the paper.

4.2 Evaluation Results

Here, we present the experimental results.

*<http://moon.nju.edu.cn/people/jingweixu/>

Table 2: The comparisons of RMSE results on Google Play and MovieLens data. The proposed methods (HoORAYs₀ and HoORAYs) outperform the compared methods.

Data set	PMF	CTR	HoORAYs ₀	HoORAYs
Google Play	1.2958	1.2842	1.2747	1.2733
MovieLens	0.7764	0.7724	0.7645	0.7620

Table 3: The comparisons of MAE results on for Google Play and MovieLens data. The proposed methods (HoORAYs₀ and HoORAYs) outperform the compared methods.

Data set	PMF	CTR	HoORAYs ₀	HoORAYs
Google Play	1.0132	0.9997	0.9855	0.9827
MovieLens	0.5977	0.5952	0.5814	0.5808

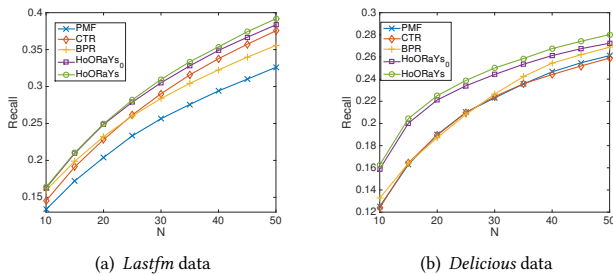

Figure 3: The comparisons of Recall@N results on lastfm and Delicious data. The proposed methods outperform the compared methods on both data sets.

Explicit user feedback. We first show the performance of the proposed methods for explicit feedback. Table 2 and Table 3 show the results on *Google Play* and *MovieLens* with *RMSE* and *MAE*, respectively.

We can first observe from the tables that, the proposed HoORAYs₀ and HoORAYs significantly outperform PMF and CTR in terms of both *RMSE* and *MAE*. For example, in Table 2, HoORAYs achieves 0.85% and 1.35% improvement over the best competitor (CTR) wrt *RMSE* on *Google Play* and *MovieLens*, respectively. As for the *MAE* metric in Table 3, HoORAYs outperforms the best competitor (CTR) by 1.70% v.s. 2.42% on *Google Play* and *MovieLens*, respectively.

Second, we can see that HoORAYs₀ also outperforms CTR on both data sets, although CTR considers content information while HoORAYs₀ does not. This indicates the importance of using high-order distance during the optimization process.

Third, the performance on the *MovieLens* data is better than that on the *Google Play* data. This is due to the fact that the *Google Play* data is much sparser than the *MovieLens* data (0.02% sparsity on *Google Play* and 3.97% sparsity on *MovieLens*).

Overall, the above results indicate that the proposed methods are more accurate than the compared methods for the case of explicit feedback, and that the high-order rating distance plays an important role for improving the prediction accuracy of recommendation.

Table 4: The comparisons of AUC results on Lastfm and Delicious data. The proposed methods (HoORAYs₀ and HoORAYs) outperform the compared methods on both data sets.

Data set	PMF	CTR	BPR	HoORAYs ₀	HoORAYs
Lastfm	0.880	0.897	0.896	0.905	0.905
Delicious	0.644	0.657	0.655	0.663	0.667

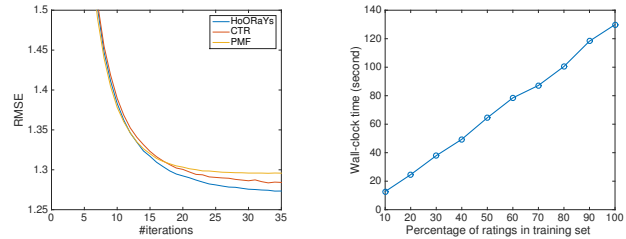

(a) Efficiency evaluation on *Google Play* data, x-axis is #iterations and y-axis is *RMSE*. (b) Scalability evaluation on *Google Play* data, x-axis is time cost and y-axis is ratings used for training.

Figure 4: Efficiency and scalability evaluation on Google Play data.

Implicit user feedback. Next, we present the results of the proposed methods for the implicit feedback case. We compare the proposed methods with PMF, CTR, and BPR, and show the results in Fig. 3 and Table 4.

In Fig. 3, we show the *Recall* results with top N from 10 to 50 with fixed step 5. As we can see, the two proposed methods HoORAYs₀ and HoORAYs significantly outperform the compared methods in all cases on both *Lastfm* and *Delicious* data. In Fig. 3(a), both HoORAYs₀ and HoORAYs are consistently better than the best competitors on *Lastfm* with 7% improvement on average. In Fig. 3(b), the proposed methods outperform the compared methods especially when number of N is small. For example, when N is 15, HoORAYs₀ and HoORAYs achieve 21.7% and 24.3% improvement over the best competitor. Overall, the proposed methods outperform the best competitors with averagely 12.6% improvement in this series of evaluation.

Similar results are observed in Table 4 which shows the *AUC* scores. Specially, we can observe that HoORAYs₀ outperforms the BPR method. This again indicates the usefulness of the proposed high-order distance minimization as BPR uses an *AUC*-like optimization target. We also notice that the results on *Lastfm* is better than that on *Delicious*. Again, this is due to the data sparsity (0.08% sparsity on *Delicious* v.s. 0.28% sparsity on *Lastfm*).

Together with the results in Table 2, Table 3, Table 4, and Fig. 3, we can conclude that the proposed methods outperform the compared methods in both explicit feedback case and implicit feedback case. Moreover, the proposed methods can outperform the compared methods even when the content information is unavailable.

Efficiency and Scalability. Next, we present the results of the proposed methods in terms of efficiency and scalability. All the

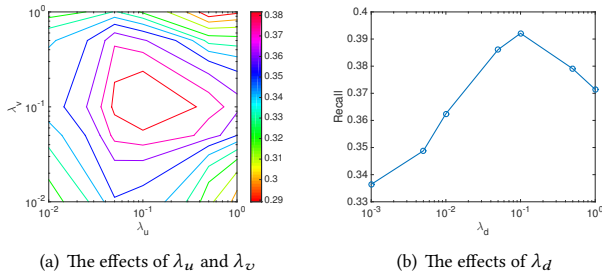

Figure 5: The effects of λ_u , λ_v , and λ_d of the proposed HoORAYs with $Recall@50$ on *Lastfm* data.

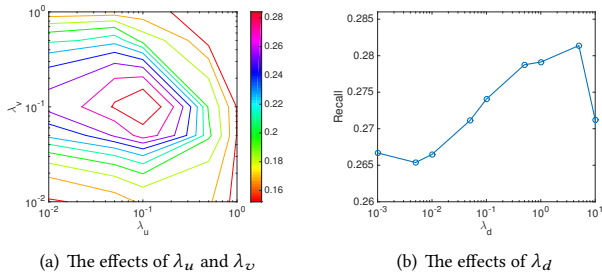

Figure 6: The effects of λ_u , λ_v , and λ_d of the proposed HoORAYs with $Recall@50$ on *Delicious* data.

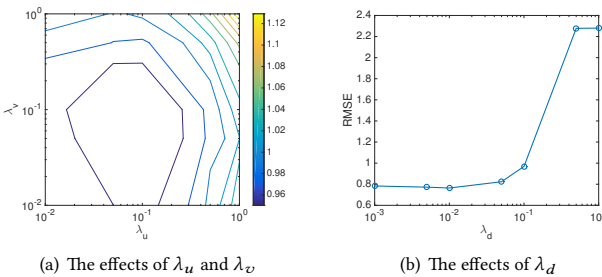

Figure 7: The effects of λ_u , λ_v , and λ_d of the proposed HoORAYs on *MovieLens* data.

experiments are run on a Macbook Pro. The machine has four 2.5GHz Intel i7 Cores and 16 GB memory.

In Fig 4(a), we show the efficiency of HoORAYs on *Google Play* data. Compared to MF and CTR, the RMSE of the proposed HoORAYs decreases faster than that of the other two methods. Especially after 13th iteration, HoORAYs still keeps high gradient descent ratio, and the RMSE value reaches the bottom as fast as MF and CTR do. Compared to MF and CTR, the proposed model reveals the equivalent ability in terms of efficiency in practice. Fig 4(b) presents the scalability evaluation for HoORAYs on *Google Play* data. We plot the wall-clock time of each iteration with different number of ratings in training set. As we can see from the figures,

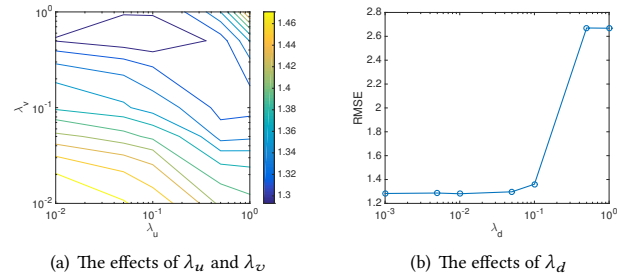

Figure 8: The effects of λ_u , λ_v , and λ_d of the proposed HoORAYs on *Google Play* data.

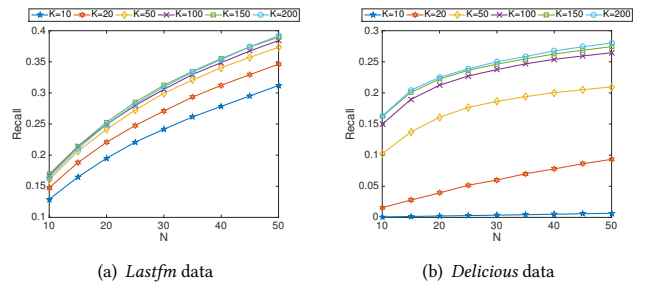

Figure 9: The effects of the latent vector dimension K of the proposed HoORAYs with $Recall$ on *Lastfm* and *Delicious* data sets.

our proposed HoORAYs scales linearly when number of ratings increases.

Study of Parameters. Finally, we conduct a parameter study of the proposed methods. We first study the parameters of λ_u , λ_v , and λ_d . We use $Recall@50$ as an example, and plot the results on *Lastfm* and *Delicious* data in Fig. 5 and Fig. 6, respectively. As we can see from the figures, HoORAYs can achieve best performance when $\lambda_u = \lambda_v = 0.1$ for both data sets. As for λ_d , HoORAYs is sensitive to this parameter, and it achieves the best performance with different λ_d for different data sets. In practice, we suggest to set $\lambda_u = \lambda_v = 0.1$ by default, and tune the λ_d parameter when using the proposed models. For the effects of parameters on data set with explicit feedback, we study the parameters of λ_u , λ_v , and λ_d on *MovieLens* and *Google Play* data, and the results are plotted in Fig. 7 and Fig. 8. For *MovieLens* data, HoORAYs have the best performance when $\lambda_u = \lambda_v = 0.1$ in Fig 7(a). As for λ_d in Fig 7(b), HoORAYs can achieve good performance when $\lambda_d < 0.05$. As a result, we select $\lambda_d = 0.01$ in our evaluation. As we can see from Fig. 8(a), HoORAYs can achieve best performance when $\lambda_u = 0.1$ and $\lambda_v = 0.5$. For λ_d , we can find the similar results in Fig. 8(b) to the results on *MovieLens* data. In practice, we select $\lambda_d = 0.01$ for the evaluation.

Another parameter of the proposed method is the latent vector's dimension K . Fig. 9 presents the effects of K with $Recall@N$ on *Lastfm* and *Delicious* data. We vary the size of K with $K = 10, 20, 50, 100, 150, 200$. In general, as shown in Fig. 9(a) and Fig. 9(b),

a larger K usually brings better performance before it overfits the data set. Fig. 9(a) shows the performance with different K selection on *Lastfm* data. We can also observe from the figures that, the *Recall* performance improves significantly when we increase K from 10 to 100, and the improvement becomes minor when K is larger than 100. In practice, we suggest to set K between 100 and 200 for the proposed HoORAYs.

5 RELATED WORK

In this section, we briefly review some related work.

Collaborative filtering approaches with user feedback as input have been widely used in recommender systems [7, 10, 11, 14]. For example, matrix factorization methods [11, 14] take ratings as input, and learn the latent vectors of users and items for recommendation. To improve recommendation accuracy, side information is also widely explored. For example, Wang et al. [20] and McAuley and Leskovec [13] incorporate content information; Ma et al. [12] and Tang et al. [19] incorporate social relationships; Chen et al. [2] and Purushotham et al. [17] consider both content and social information.

While many recommendation algorithms are designed for explicit user feedback, several researchers put their focus on case of implicit user feedback. For example, Rendle et al. [18] propose Bayesian personalized ranking to optimize the rankings instead of ratings. Formulating the problem as one-class collaborative filtering, traditional approaches are also adapted for implicit feedback [8, 15, 16], and side information is also considered in this one-class setting [23, 24].

Different from and orthogonal to most of the existing recommendation methods, we propose a new regularized optimization problem by involving high-order rating distance as the constraint for shrinking the solution space. By reducing the *variance*, the better recommendation accuracy could be reached. Similar strategies are also explored in some related problems. For example, Rendle et al. [18] and Kabbur et al. [9] propose an *AUC*-like optimization function. Our high-order optimization problem is different from the *AUC*-like optimization as we use the other existing ratings to shrink the solution space while *AUC* focuses on the order of observed-unobserved examples; additionally, we have experimentally shown that the proposed method outperforms BPR with same input. This work generalizes the rating comparison strategy [21, 22], which can be viewed as a second-order rating distance, primarily designed for the cold-start case. Moreover, it also justifies the rationality behind the higher-order rating distance from two complementary perspectives (the geometric vs. Bayesian interpretations).

6 CONCLUSION

In this paper, we have proposed a high-order optimization of rating distance for recommender systems HoORAYs to further reduce the solution space of latent vectors for users and items. The proposed HoORAYs model used second-order rating distance as the constraint to the optimization problem. HoORAYs can be applied for both explicit and implicit user feedback. We presented a geometric interpretation to show how HoORAYs helps reduce the *variance* of the estimated latent factors. Based on the Bayesian interpretation, we further explained the HoORAYs from the generative model

perspective. By connecting to CTR rating model, our HoORAYs can naturally handle the case when content information is available. The experimental evaluations on four real-world data sets show that the proposed method consistently outperforms the state-of-the-art methods in terms of prediction accuracy.

ACKNOWLEDGMENTS

This work is supported by the National 863 Program of China (No. 2015AA01A203), National Key Research and Development Program of China (No. 2016YFB1000802), National Natural Science Foundation of China (No. 61373011, 61690204), the Collaborative Innovation Center of Novel Software Technology and Industrialization. This work is supported by NSF (IIS-1651203), DTRA (HDTRA1-16-0017), ARO (W911NF-16-1-0168), NIH (R01LM011986), and a Baidu gift.

REFERENCES

- [1] Iván Cantador, Peter Brusilovsky, and Tsvi Kuflik. 2011. 2nd Workshop on Information Heterogeneity and Fusion in Recommender Systems (HetRec 2011). In *Proceedings of the 5th ACM conference on Recommender systems (RecSys 2011)*. ACM, New York, NY, USA.
- [2] Chaochao Chen, Xiaolin Zheng, Yan Wang, Fuxing Hong, Zhen Lin, and others. 2014. Context-Aware Collaborative Topic Regression with Social Matrix Factorization for Recommender Systems. In *AAAI*, Vol. 14. 9–15.
- [3] Ning Chen, Steven CH Hoi, Shaohua Li, and Xiaokui Xiao. 2015. SimApp: A framework for detecting similar mobile applications by online kernel learning. In *Proceedings of the Eighth ACM International Conference on Web Search and Data Mining*. ACM, 305–314.
- [4] Abhinandan S Das, Mayur Datar, Ashutosh Garg, and Shyam Rajaram. 2007. Google news personalization: scalable online collaborative filtering. In *Proceedings of the 16th international conference on World Wide Web*. ACM, 271–280.
- [5] Stuart Geman, Elie Bienenstock, and René Doursat. 1992. Neural networks and the bias/variance dilemma. *Neural computation* 4, 1 (1992), 1–58.
- [6] Pankaj Gupta, Ashish Goel, Jimmy Lin, Aneesh Sharma, Dong Wang, and Reza Zadeh. 2013. Wtf: The who to follow service at twitter. In *Proceedings of the 22nd international conference on World Wide Web*. ACM, 505–514.
- [7] Jonathan L Herlocker, Joseph A Konstan, Al Borchers, and John Riedl. 1999. An algorithmic framework for performing collaborative filtering. In *Proceedings of the 22nd annual international ACM SIGIR conference on Research and development in information retrieval*. ACM, 230–237.
- [8] Yifan Hu, Yehuda Koren, and Chris Volinsky. 2008. Collaborative filtering for implicit feedback datasets. In *Data Mining, 2008. ICDM'08. Eighth IEEE International Conference on*. IEEE, 263–272.
- [9] Santosh Kabbur, Xia Ning, and George Karypis. 2013. FISM: factored item similarity models for top-N recommender systems. In *ACM SIGKDD International Conference on Knowledge Discovery and Data Mining*. ACM, 659–667.
- [10] George Karypis. 2001. Evaluation of item-based top-n recommendation algorithms. In *Proceedings of the tenth international conference on Information and knowledge management*. ACM, 247–254.
- [11] Yehuda Koren, Robert Bell, and Chris Volinsky. 2009. Matrix factorization techniques for recommender systems. *Computer* 42, 8 (2009), 30–37.
- [12] Hao Ma, Tom Chao Zhou, Michael R Lyu, and Irwin King. 2011. Improving recommender systems by incorporating social contextual information. *ACM Transactions on Information Systems (TOIS)* 29, 2 (2011), 9.
- [13] Julian McAuley and Jure Leskovec. 2013. Hidden factors and hidden topics: understanding rating dimensions with review text. In *Proceedings of the 7th ACM conference on Recommender systems*. ACM, 165–172.
- [14] Andriy Mnih and Ruslan Salakhutdinov. 2007. Probabilistic matrix factorization. In *NIPS*. 1257–1264.
- [15] Rong Pan, Yunhong Zhou, Bin Cao, Nathan Nan Liu, Rajan Lukose, Martin Scholz, and Qiang Yang. 2008. One-class collaborative filtering. In *Data Mining, 2008. ICDM'08. Eighth IEEE International Conference on*. IEEE, 502–511.
- [16] Ulrich Paquet and Noam Koenigstein. 2013. One-class collaborative filtering with random graphs. In *Proceedings of the 22nd international conference on World Wide Web*. ACM, 999–1008.
- [17] Sanjay Purushotham, Yan Liu, and C-C Jay Kuo. 2012. Collaborative topic regression with social matrix factorization for recommendation systems. *arXiv preprint arXiv:1206.4684* (2012).
- [18] Steffen Rendle, Christoph Freudenthaler, Zeno Gantner, and Lars Schmidt-Thieme. 2009. BPR: Bayesian personalized ranking from implicit feedback. In

- Proceedings of the twenty-fifth conference on uncertainty in artificial intelligence.* AUAI Press, 452–461.
- [19] Jiliang Tang, Xia Hu, Huiji Gao, and Huan Liu. 2013. Exploiting Local and Global Social Context for Recommendation. In *IJCAI*. 264–269.
- [20] Chong Wang and David M Blei. 2011. Collaborative topic modeling for recommending scientific articles. In *Proceedings of the 17th ACM SIGKDD international conference on Knowledge discovery and data mining*. ACM, 448–456.
- [21] Jingwei Xu, Yuan Yao, Hanghang Tong, Xianping Tao, and Jian Lu. 2015. Ice-breaking: mitigating cold-start recommendation problem by rating comparison. In *Proceedings of the 24th International Conference on Artificial Intelligence*. AAAI Press, 3981–3987.
- [22] Jingwei Xu, Yuan Yao, Hanghang Tong, Xianping Tao, and Jian Lu. 2016. RaPare: A Generic Strategy for Cold-Start Rating Prediction Problem. *IEEE Transactions on Knowledge and Data Engineering* (2016).
- [23] Yuan Yao, Hanghang Tong, Guo Yan, Feng Xu, Xiang Zhang, Boleslaw K Szymbanski, and Jian Lu. 2014. Dual-regularized one-class collaborative filtering. In *Proceedings of the 23rd ACM International Conference on Conference on Information and Knowledge Management*. ACM, 759–768.
- [24] Xiaodong Zheng, Hao Ding, Hiroshi Mamitsuka, and Shanfeng Zhu. 2013. Collaborative matrix factorization with multiple similarities for predicting drug-target interactions. In *Proceedings of the 19th ACM SIGKDD international conference on Knowledge discovery and data mining*. ACM, 1025–1033.