



# Low-cost Arduino controlled dual-polarity high voltage power supply

Eric J. Davis<sup>a,\*</sup>, Brian H. Clowers<sup>b</sup>

<sup>a</sup> Whitworth University, Department of Chemistry, 300 W Hawthorn Rd, Spokane, WA 99251, United States

<sup>b</sup> Washington State University, Department of Chemistry, PO Box 644630, Pullman, WA 99164, United States



## ARTICLE INFO

### Article history:

Received 31 May 2022

Received in revised form 18 October 2022

Accepted 27 November 2022

### Keywords:

Ion Mobility Spectrometry

High Voltage

Power Supply

Laboratory Instrumentation

Chemical Instrumentation

## ABSTRACT

Ion Mobility Spectrometry (IMS) provides low ppbv detection limits for gas-phase or aqueous analytes. These instruments rely on an electric field to produce ion motion. This electric field is typically 200–600 V/cm with a 15 cm cell, requiring an HV source of 6–10 kV. In this work, we present a low-cost alternative for supplying this high voltage. Inexpensive, commercially available 0–20 kV HV modules are mapped to an analog 0–5 V input signal, controlled using an Arduino microcontroller and digital analog converter. Dual polarities are selectable through a front-panel switch and ramps potentials between settings to avoid damage to attached devices.

© 2022 The Author(s). Published by Elsevier Ltd. This is an open access article under the CC BY-NC-ND license (<http://creativecommons.org/licenses/by-nc-nd/4.0/>).

## Specifications table

Hardware name	<i>Arduino Controlled Dual-Polarity High Voltage Power Supply</i>
Subject area	<ul style="list-style-type: none"> <li>• Engineering and materials science</li> <li>• Chemistry and biochemistry</li> <li>• Environmental, planetary and agricultural sciences</li> <li>• Educational tools and open-source alternatives to existing infrastructure</li> <li>• General</li> </ul>
Hardware type	<ul style="list-style-type: none"> <li>• Electrical engineering and computer science</li> <li>• Measuring physical properties and in-lab sensors</li> </ul>
Closest commercial analog	<i>XP Power FJ20R040 – 20 kV, 40 W reversible HV power supply</i> <i>FuG HCP-35-20000 – 20 kV, 30 W reversible HV power supply</i>
Open source license	<i>Creative Commons Attribution 3.0 United States</i>
Cost of hardware	<i>~\$1,200 for the HV modules (depending on maximum voltage desired) plus \$500 for Arduino control system. \$1,700 total for a 20 kV dual polarity supply.</i>
Source file repository	<a href="https://doi.org/10.5281/zenodo.7221871">https://doi.org/10.5281/zenodo.7221871</a>

\* Corresponding author.

E-mail address: [ericdavis@whitworth.edu](mailto:ericdavis@whitworth.edu) (E.J. Davis).

## Hardware in context

The Arduino HV power supply system has been specifically designed as an affordable alternative to commercially available high voltage power supplies for use with Ion Mobility Spectrometry (IMS) [1,2], especially PCB-IMS system in modern use [3–5]. IMS cells typically consist of 20–60 individual, stacked, electrically separated, ring-shaped electrodes connected through a resistor chain on the order of 50 M $\Omega$ . Application of high voltage at the front of the tube and ground to the end of the resistor chain produces an electric field into which gas-phase ions may be introduced and separated according to their size-to-charge ratios [6,7]. These separations allow parts-*per-billion* level detection limits of analytes and IMS is especially useful within military and security applications in the detection of trace levels of explosives [2,8], narcotics [9,10], and chemical warfare agents [11].

The operation of an IMS cell requires a highly stable High Voltage (HV) power supply with minimal ripple and programmable output to account for atmospheric conditions and optimal separation characteristics in the IMS experiment [12–15]. While such power supplies are commercially available, the advent of low-cost IMS cells through the application of printed-circuit boards (PCB) for the IMS cell and associated electronics [3] has resulted in an IMS cell that costs less than \$1,000 for everything except the HV power supply. The application of PCB's to IMS has recently produced a numerous modifications to the IMS experiment, especially low-cost portable systems [16], cyclic IMS [17], PEEK-based stacked IMS cells [18], and Structures for Lossless ion Manipulations (SLIM) [19,20]. While SLIM and cyclic IMS systems require custom power supplies and circuit design, a typical drift-time IMS cell requires two HV supplies, one to power the IMS cell and a second to provide a potential bias to an ionization source. Select configurations exist that allow for the source power supply to float on the HV used for the IMS, however, in most applications two supplies are generally required. The high cost of such commercial supplies (over \$5,000) makes this the single most expensive portion of a drift-time IMS experiment.

This work demonstrates an Arduino-controlled power supply using commercially available HV power supply modules at a fraction of the cost of a typical HV supply for the IMS cell or ionization source. This is a dual-mode supply that allows for the rapid switching of polarity (positive or negative) from a single supply source.

## Hardware description

The hardware described herein is intended as a multipurpose high voltage power supply system with digital control over the output potential from commercially purchased high voltage supply modules. Designed originally for use with Ion Mobility Spectrometry (IMS), this supply design will work for any high voltage, low current applications and allow rapid and simple potential and polarity adjustments in an inexpensive package. *The safety controls and circuit are not designed for user safety in a high current application. Any modification to a high current application should be performed with care and under the guidance of experienced high energy consultants. The HV modules used herein are factory limited to a maximum of 1 mA output with a maximum of 1,000 pF output capacitance and 0.2 J stored energy; sufficient for application to IMS while ensuring user safety below the safety threshold of 10 J. This system does demonstrate a shock hazard due to its output greater than 50 V<sub>rms</sub> [21].*

The front panel and LCD screen provide a user interface for potential selection and control of high voltage output from the supply in either positive or negative modes. A simple user interface utilizes a rotary encoder to select menu items, set output potentials, view output voltage, and initiate or disable high voltage output. For safety, the front panel includes a high voltage enable/disable switch and a rapid shutdown button in the center with a latching action. If this button is pushed (from any screen on the user interface), internal relays immediately close, grounding the power supply modules voltage adjustment pins and disabling all external high voltage, resulting in the power supply discharging to ground as rapidly as possible through the applied load. With the exception of this mode, enabling or disabling power supplies results in a 1,000 V/s ramp rate to protect both internal and external circuits from sudden onset of high voltage. The ramp rate is adjustable within the Arduino software (it is not editable from the user interface). Dual polarity is provided through the utilization of two internal power supply modules, one positive, one negative, with identical output characteristics. A front panel switch allows user selection of either mode with LED indicators on the front and rear panels to demonstrate which mode and connectors to use for the external equipment. Changing polarity requires both switching the front panel switch and swapping the rear cable between outputs. Alternative hardware designs to position these HV connectors on the front panel for applications where polarity is frequently changed are provided.

Digital control is produced through an Arduino Uno R3 microcontroller manipulating a digital analog voltage converter (DAC) (Adafruit MCP4725). The DAC allows 12-bit control in the range of zero to maximum (5) volts, corresponding to zero to 100 % of the output capability of the power supply modules. EEPROM memory algorithms allow microcontroller recall of the prior HV setting. While the absolute value of the electric field is essential for IMS, reproducibility of the setting is equally important during experimentation. The capacity to return to the same setting digitally provides an additional level of reproducibility that is difficult to achieve using analog-only controls. Connection from the DAC to the HV modules (ESD-EMC HVM-A-203.13 P24) is routed through a pair of relays (Sainsmart 2-Channel 5 V Relay Module) independently controlled by the Arduino. When the user selects positive mode, the positive relay switches to state 1 and DAC potentials are routed to the voltage adjustment pin of the positive HV module. Conversely, the negative mode relay is switched to state 2 where ground is permanently wired, disabling the negative HV module while the positive module is in use. User selection of negative mode has the opposite effect, where the positive supply's adjustment pin is grounded and the negative supply's pin is

routed to the DAC output. For use with IMS, only one polarity is required at any given time, so the use of the supply in both simultaneously was purposefully disabled. Rapid shutdown mode places both relays in state 2 immediately and disables all HV output until the switch is released. Upon release, the power supply is set back to a default, HV off condition and has the same programmatic effect as power cycling the unit.

The system is powered by an internal 24 V, 2.71 A AC/DC power supply (Mean Well EPS-65-24-C). This +24 V rail is used to power the HV modules, a pair of internal cooling fans, and an LM2596 buck converter set to +9 V output. The +9 V rail is used to power the Arduino controller. All I2C components (Rotary Encoder, LCD screen, and DAC) are connected to the Arduino through a Grove (Seeed Studio Grove Base Shield V2.0) quick-connect shield and are powered by the +5 V rail provided by the Arduino. All LED's and switches are powered by this +5 V rail through digital control channels of the Arduino. External HV connectors use an Alden style plug and receptacle for high voltage isolation and safety and a rear panel grounding stud allows HV return to the modules' sinks. Each connector is labeled with color-coded LED indicators for user clarity on the active module at any given time. A rear panel HV active LED provides for user safety when switching polarities to avoid connector removal while HV is active.

- High voltage digitally controlled through an MCP4725 digital analog converter. This provides 4,096 steps along the range of voltages produced by the power supply module. For a 20 kV supply, this provides a minimum voltage change of 4.88 V per delineation.
- Arduino control allows for customizability in both hardware and software.
- Grove connectors provide rapid plug and play connectivity.
- Internal power supplies provide +24 and +9 V rails to the Arduino and HV power supply modules. Arduino outputs provide a +5 V rail for I2C and LED components.
- Internal relays pull adjustment pins of power supplies to ground when not in use to disable them.

### Design files summary

Design file name	File type	Open source license	Location of the file
Arduino PS 2.0.sch	Eagle Schematic	<i>Creative Commons Attribution 3.0 United States</i>	<a href="https://doi.org/10.5281/zenodo.7221871">https://doi.org/10.5281/zenodo.7221871</a>
Arduino_Control_4.0.ino	Arduino Program	<i>Creative Commons Attribution 3.0 United States</i>	<a href="https://doi.org/10.5281/zenodo.7221871">https://doi.org/10.5281/zenodo.7221871</a>
Bottom Panel.ipt	Inventor Design File	<i>Creative Commons Attribution 3.0 United States</i>	<a href="https://doi.org/10.5281/zenodo.7221871">https://doi.org/10.5281/zenodo.7221871</a>
Bottom Panel.dwg	Inventor Design File	<i>Creative Commons Attribution 3.0 United States</i>	<a href="https://doi.org/10.5281/zenodo.7221871">https://doi.org/10.5281/zenodo.7221871</a>
Front Panel.ipt	Inventor Design File	<i>Creative Commons Attribution 3.0 United States</i>	<a href="https://doi.org/10.5281/zenodo.7221871">https://doi.org/10.5281/zenodo.7221871</a>
Front Panel.dwg	Inventor Design File	<i>Creative Commons Attribution 3.0 United States</i>	<a href="https://doi.org/10.5281/zenodo.7221871">https://doi.org/10.5281/zenodo.7221871</a>
Rear Panel.ipt	Inventor Design File	<i>Creative Commons Attribution 3.0 United States</i>	<a href="https://doi.org/10.5281/zenodo.7221871">https://doi.org/10.5281/zenodo.7221871</a>
Rear Panel.dwg	Inventor Design File	<i>Creative Commons Attribution 3.0 United States</i>	<a href="https://doi.org/10.5281/zenodo.7221871">https://doi.org/10.5281/zenodo.7221871</a>
Side Panel.ipt	Inventor Design File	<i>Creative Commons Attribution 3.0 United States</i>	<a href="https://doi.org/10.5281/zenodo.7221871">https://doi.org/10.5281/zenodo.7221871</a>
Side Panel.dwg	Inventor Design File	<i>Creative Commons Attribution 3.0 United States</i>	<a href="https://doi.org/10.5281/zenodo.7221871">https://doi.org/10.5281/zenodo.7221871</a>
BOM.xlsx	Excel File	<i>Creative Commons Attribution 3.0 United States</i>	<a href="https://doi.org/10.5281/zenodo.7221871">https://doi.org/10.5281/zenodo.7221871</a> and <a href="#">Supplementary materials</a>
Combined Design Files.zip	Zip File	<i>Creative Commons Attribution 3.0 United States</i>	<a href="https://doi.org/10.5281/zenodo.7221871">https://doi.org/10.5281/zenodo.7221871</a>
Alternative Design.zip	Zip File	<i>Creative Commons Attribution 3.0 United States</i>	<a href="https://doi.org/10.5281/zenodo.7221871">https://doi.org/10.5281/zenodo.7221871</a>

[Arduino PS.sch](#) – Schematic of modular high voltage power supply. Also pictured as [Fig. 5](#).

[Arduino\\_Control\\_4.0.ino](#) – Arduino code for uploading firmware to microcontroller. Will require the Arduino application or online account with Arduino for flashing firmware.

[Bottom Panel.ipt](#) – Design schematic for bolt pattern layout of the bottom panel of the power supply box. Created using Autodesk Inventor 2022. Also pictured in [Fig. 3](#).

[Front Panel.ipt](#) – Design schematic for bolt pattern layout of the front panel of the power supply box. Created using Autodesk Inventor 2022. Also pictured in [Fig. 2](#).

[Rear Panel.ipt](#) – Design schematic for bolt pattern layout of the rear panel of the power supply box. Created using Autodesk Inventor 2022. Also pictured in [Fig. 2](#).

[Side Panel.ipt](#) – Design schematic for bolt pattern layout of the side panels of the power supply box. Created using Autodesk Inventor 2022. Also pictured in [Fig. 4](#).

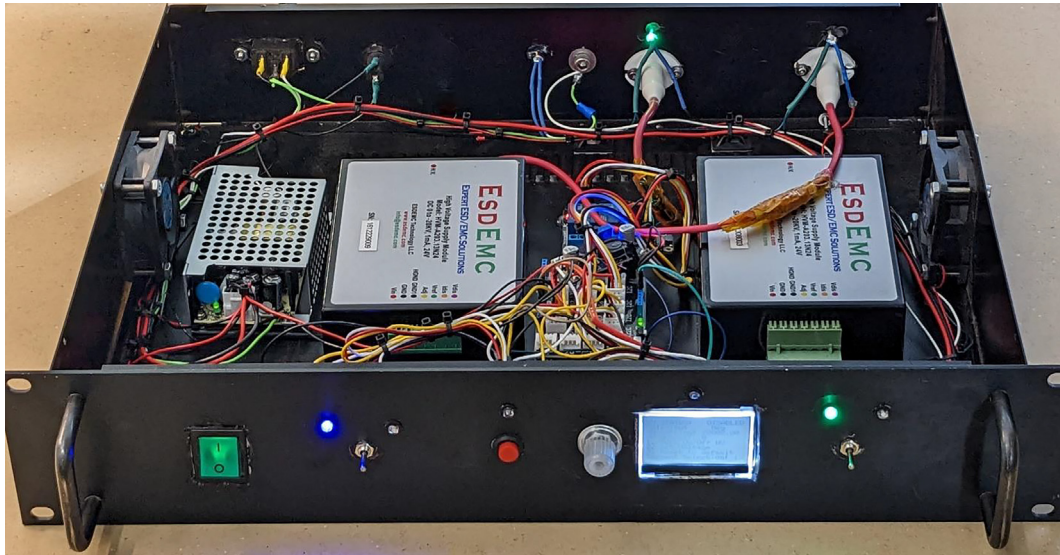

Fig. 1. Assembled HV power supply.

[BOM.xlsx](#) – Bill of materials itemized list. Also uploaded to [Supplementary Materials](#).

[Combined Design Files.zip](#) – Compressed (ZIP) file containing all files listed above, plus \*.dwg and \*.pdf files for the inventor files to allow printing.

[Alternative Design.zip](#) – Compressed (ZIP) file containing alternative versions of the \*.ipt files described above for front panel outputs.

### Bill of materials summary

Bill of Materials attached in [supplementary material](#) and provided in Zenodo Repository.

### Build instructions

In this section, assembly of the dual polarity HV power supply as shown in [Fig. 1](#) is described. This is broken into 3 distinct sections: *2U Rack Mount Enclosure Preparation*, *Internal Wiring*, and *Software Setup*.

#### 2U Rack Mount Enclosure Preparation:

Before the circuit may be constructed, the rack mount box must be modified to allow for the connectors, ports, and user interface modules to pass through to the internals of the box. This includes both front and rear panel openings which must be created in the metal box. [Fig. 2a](#) provides schematics of the front panel and [Fig. 2b](#) provides schematics of the rear panel. A label maker or laser engraver may be used to label each control as desired. A drill with standard indexed bits may be used for all round holes (LED, switches, buttons, and fuses). A rotary cutoff tool may be used for the square openings (LCD, power switch, and power in). LED's (colors overlaid in the label images in [Fig. 2](#)) are held in place with LED panel mount holders (BOM Line 4), switches, buttons, encoders, and fuses are threaded using included hardware, the power switch is held in place with integrated friction connectors, and the power in and HV out connectors are attached with external hardware. All designs are set for either #6 (power in) or #8 (HV out connectors) ANSI hardware. The grounding stud is an ANSI ¼ – 20 bolt. We found it advantageous to use a small amount of hot glue to protect the exposed leads internally and prevent any movement of the LEDs once mounted.

With the front and rear panels drilled and all components installed, the bottom and side panels were prepared for bolting all internal components. [Fig. 3](#) demonstrates the bottom panel drilling diagram and a top-down view of the assembled power supply with all internals. The HV power supplies are attached to the bottom panel using #8 ANSI hardware. The Arduino and relay module are attached to the bottom panel using #6 ANSI hardware. Finally, the 24 V power supplies are attached to the bottom panel using M3x4mm screws.

The side panels should be prepared according to [Fig. 4](#) to allow mounting of cooling fans for the internal components. The 60 mm hole may be cut using a rotary cutting tool or large step, while the mounting holes are designed for #8 ANSI hardware; 1.5 in. bolts are necessary to extend through the fans for mounting purposes. Two panels should be prepared, mirror images (200 mm from the front of the supply for each fan). Fan guards are placed on the outside, fans on the inside with one fan as an inlet and the second as an outlet to ensure air movement across all internal components. Once all components have been installed, assemble the box according to manufacturer instructions, leaving the top cover off for access.

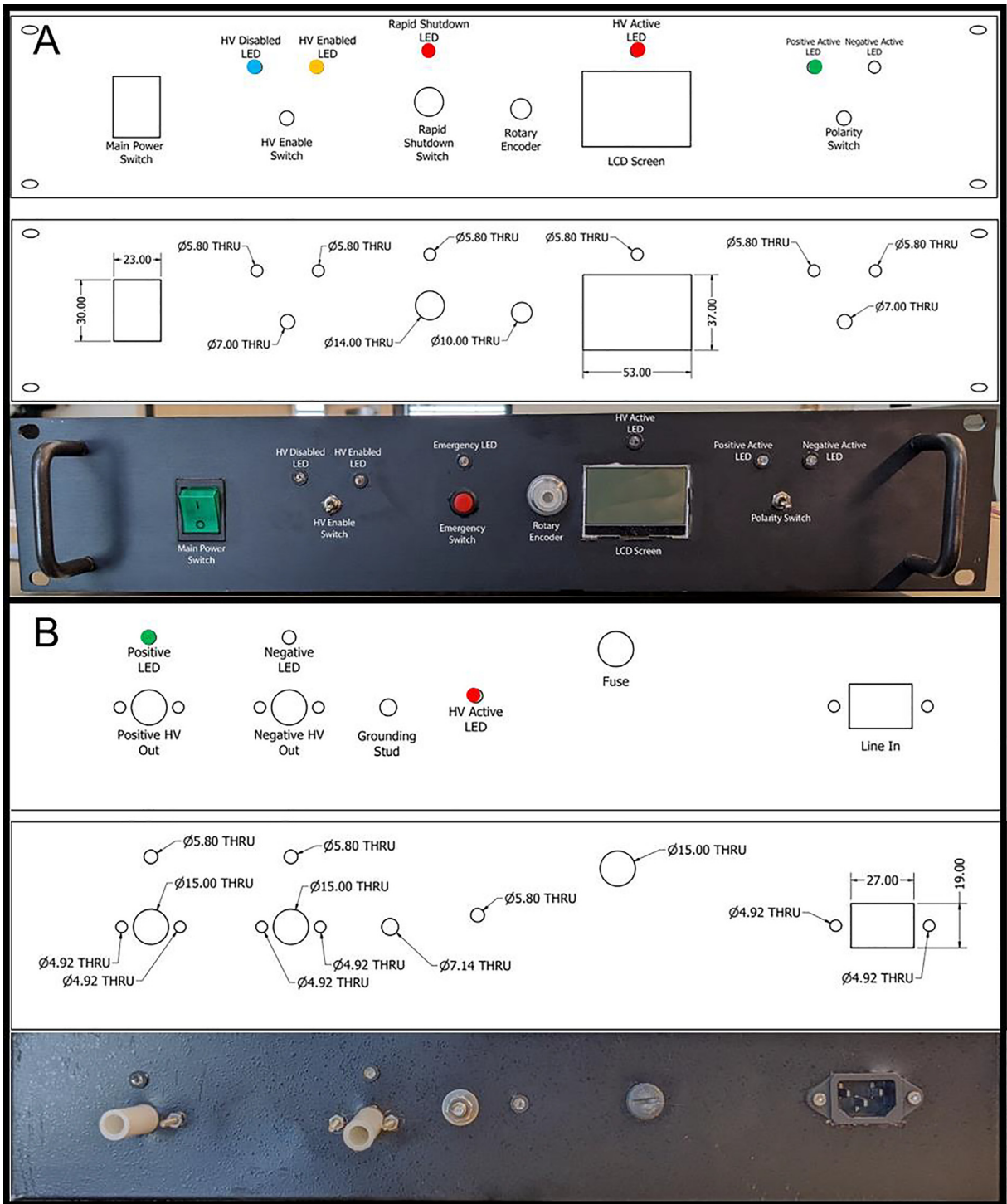
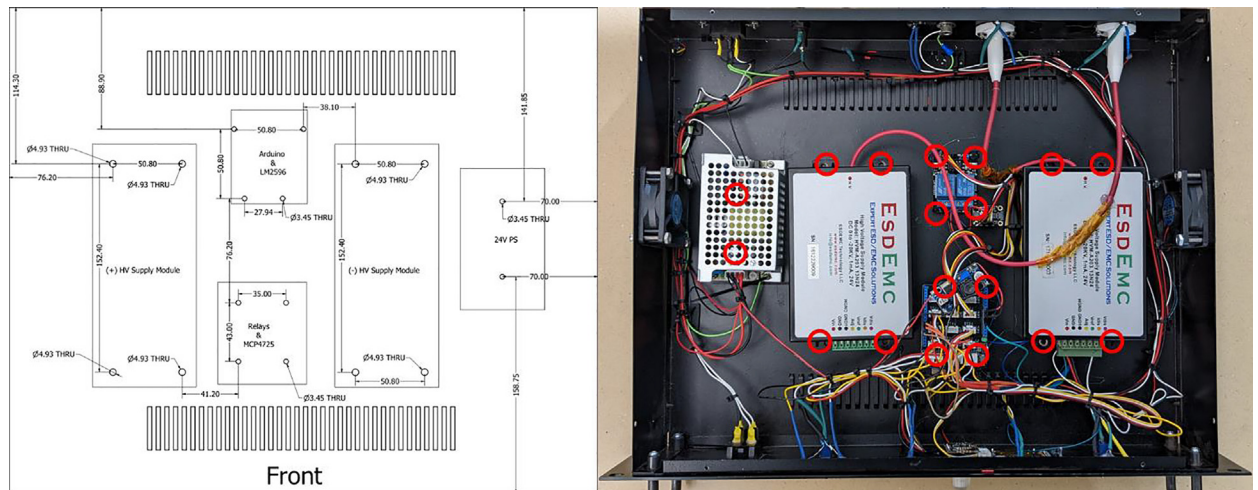

Fig. 2. Panel labeling (top), cutout (middle), and photograph of completed panel (bottom) for both Front (A) and Rear (B) panels.

Circuit preparation

Depending on options selected when purchased, the I2C encoder may require assembly. Please follow manufacturer's directions for soldering the rotary encoder to the provided PCB board. Once attached, use solder to jumper the connections on the bottom of the PCB at the points A0, A5, and A6 to set the encoder's I2C address. With these soldered connections, the



**Fig. 3.** Bottom Panel hole diagram and component layout. Red circles in image indicate locations of hardware for each attached component. (For interpretation of the references to color in this figure legend, the reader is referred to the web version of this article.)

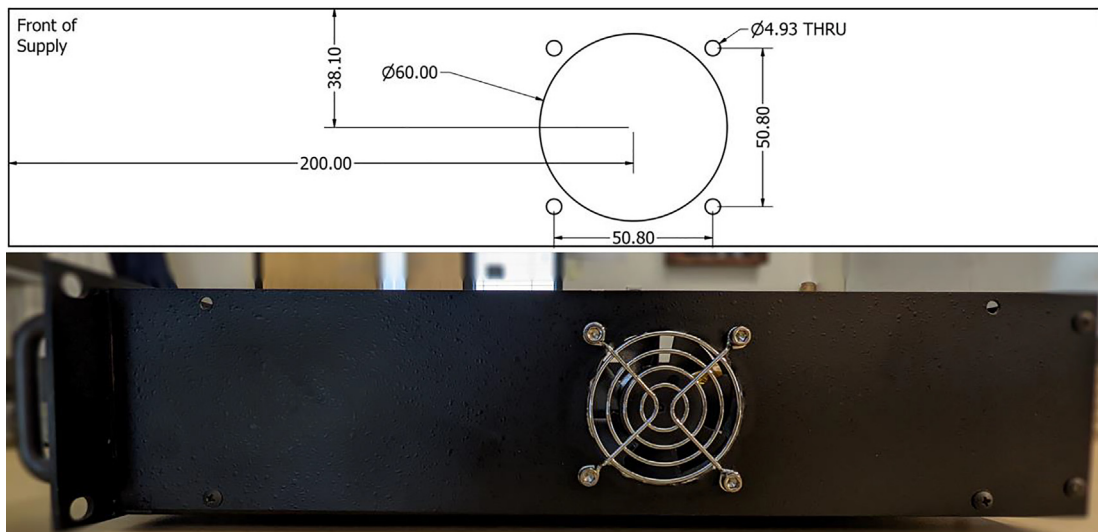
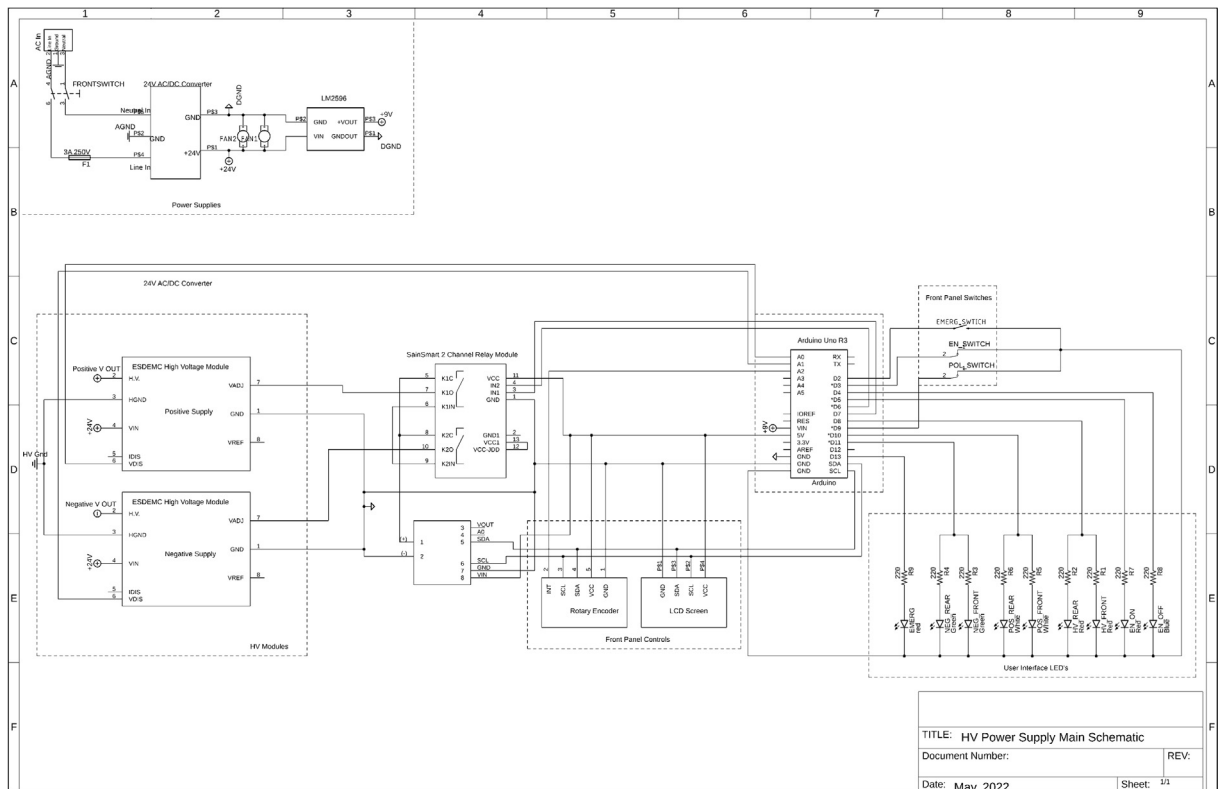

**Fig. 4.** Side panel for HV power supply. Two panels (left and right) should be prepared.

I<sub>2</sub>C addresses are set as follows: LCD I<sub>2</sub>C address: 0x51 (default); Rotary Encoder I<sub>2</sub>C address: 0x61 (A0, A5, and A6 jumpers soldered); MCP4725 I<sub>2</sub>C address: 0x62 (default).

### Internal wiring

With all internal components in place, wiring should be accomplished according to the schematics detailed in Fig. 5. An image of the completed device internals is shown in Fig. 3. The LCD display may be connected to the Arduino using a Grove connector (BOM Line 20) while the rotary encoder (BOM Line 3) and digital potentiometer (BOM Line 16) are attached with a Grove to Molex pin adapter (BOM Line 19). All other connections are soldered and joins are protected with heat shrink tubing (BOM Line 29). The wiring shown made heavy use of modified Grove to Molex connectors to connect each device to the pin-outs of the Arduino Grove Shield (BOM Line 19). In this application, the Molex connectors were cut off and components were directly soldered in place for secure connections. All soldered connections should be covered with an appropriate heat shrink tubing (BOM Line 29). Wiring order is most easily performed as outlined below:



**Fig. 5.** Schematic of Power Supply Wiring. All connections made should either be soldered or using Grove Connectors for electrical safety. HV outputs must use appropriately shielded HV rated connectors.

### Wiring Order:

1. AC Line in (hot and neutral) wired to front switch (DPST) (BOM 12).
2. AC Line in, Neutral, and ground connections to 24 V power supply (BOM 8)
  - a. Both Line in and Neutral are switched by the DPST before the 24 V supply.
  - b. Line in should be wired in series with the fuse (BOM 11 and 25).
  - c. Line in and Neutral connections are made through a VHR-3 N (BOM 35) connector using a SH connector contact (BOM 37) crimp connected to the neutral line.
  - d. Ground is connected to the chassis of the 24 V supply using an M2 screw
3. Wire line in ground to the grounding stud
4. From 24V supply using VHR-4N connector (BOM 36) and VH connector contact (BOM 37).
  - a. Connect (+) to red on both fan (solder)
  - b. Connect (+) to (+) input on an LM2596 buck converter (BOM 14) (**9V rail output**)
  - c. Connect (+) to Vin (Red pin) on HV power supply
  - d. Connect (-) to black on both fans (solder)
  - e. Connect (-) to (-) input on buck converter.
  - f. Connect (-) to HV power supply V-in GND
5. Flash control software onto the Arduino according to instructions provided with the Arduino microcontroller.
6. Solder a Molex connector to the (+) and (-) output terminals of the LM2596.
7. Attach standoffs to the Arduino UNO (BOM 6)
8. Attach a standoff to the rearmost connection hole on the Grove shield (BOM 17). Connect the LM2596 to this standoff and plug the LM2596 outputs into the "Vin and Gnd" terminals of the Arduino Grove shield.
9. Affix the Grove shield to the Arduino Uno.
10. Install Arduino onto base plate using screws into the bottom of the standoffs (BOM 34).
11. Solder HV output lines to the respective HV connectors (BOM 13). **Care must be taken with this high voltage connection.** Use multiple layers heat shrink tubing rated for high voltage applications. Fig. 3 demonstrates using polyimide film tape (yellow) as a high voltage barrier (BOM Line 32).

12. Attach both HV modules to the baseplate using #6 ANSI screws through the previously drilled holes. It is helpful to detach the control pin output from the HV supply at this step so wiring may occur externally.
13. Attach HV connectors to the rear panel using #6 ANSI screws through the previously drilled holes.
14. Use Grove cable to connect from one I2C port to the LCD screen
15. Use Grove to Molex cable to connect from another I2C port to the rotary encoder (pay attention to the pinout diagram).
16. Use a female to male Molex connector (BOM 31) to connect the encoder pin "int" to A3 on the Arduino.
17. Install standoffs onto the relay module (BOM 34). One standoff near the output pins of the relay should be connected through an upper standoff for connecting the MCP4725 (BOM 16) to the relay module.
18. Solder output wires onto the "Optional Output" pins of the MCP4725. These provide ground (referenced to the Arduino Gnd pin) and output voltage to supply the relay.
19. Attach the MCP4725 to the relay module standoff previously installed.
20. Use a Grove to Molex cable to connect from Grove Shield D6 to the relay box. IN1 should connect to D7, IN2 should be connected to D6.
21. Connect (+) output of the MCP4725 to pins 6 and 9 on the relay circuit
22. Connect (-) output of the MCP4725 to pins 5 and 8 on the relay circuit.
23. Connect GND from each HV supply to pins 5 and 8 on the relay circuit to reference the Arduino ground to the HV supply ground.
24. From the bottom relay (K1), connect the center pin (10) to VADJ of HV Power Supply 2 (Negative)
25. From the top relay (K2), connect the center pin (7) to VADJ of HV Power Supply 1 (Positive)
26. Use a Grove to Molex cable to connect from an Arduino I2C port to the MCP4725.
27. Attach the Relay/MCP4725 module to the bottom plate using the previously drilled holes and appropriate screws for the standoffs used.
28. Connect HV GND on both power supplies to the grounding stud internally.
29. Connect Vdis on the positive HV supply to pin A0 on the Arduino.
30. Connect Vdis on the negative HV supply to pin A1 on the Arduino.
31. Insert the wired connector back into each HV supply.
32. Solder 220  $\Omega$  resistors (BOM 21) onto the anode of each LED.
33. Solder from the resistor on each LED to the respective digital Arduino channel (see schematics). Grove connectors may be used to connect to the respective digital I/O pins as desired.
34. Wire each LED cathode to the Arduino ground rail.
35. Connect one side of each switch (Rapid Shutdown, HV Enable, and Polarity) to Arduino ground rail.
36. Connect the second side of each switch to the respective digital Arduino channel (see schematics).

Once all wires are connected, zip connectors should be used to combine cables into bundles to allow proper airflow through the combined unit. Once complete, the system will need to be tested to ensure accurate wiring and proper HV control according to the following procedure. **Warning, this step requires the ability to measure high voltages safely. Ensure appropriate engineering controls to protect users and equipment from high voltage exposure.** *The procedure outlined below assumes correct values at each step before proceeding to the next step. If an erroneous result is observed, immediately stop the test and correct any circuit errors before proceeding.*

1. Internally, disconnect the supply connectors (green) to both HV supply modules to prevent their activation during initial testing.
2. Plug the supply into building power, turn on the supply, and wait for the home screen to appear.
3. Disable HV power supplies via the front panel switch and observe the relays. Both relays should show a red (state 2) light.
4. Enable HV power supplies via the front panel switch and observe the relays. One should be in state 1 (red LED off on the relay) and the other should be on, corresponding to the selected polarity.
5. Switch the polarity and ensure the relays change to the appropriate states for the second supply.
6. Press the "rapid shutdown" button and observe the relays; they should both indicate State 2 (red LED active).
7. Release the rapid shutdown switch before proceeding.
8. Using a DMM, measure the output of the MCP4725. It should read 0.00 V if the HV output has not been activated.
9. Set a potential of 10,000 V, enable HV, and note the MCP4725 output. It should read 2.5 V. Repeat for a series of set potentials and observe the output with reference to a 0–5 V control potential.
10. Set output to 100 V, turn off HV, turn off the main power switch, and unplug the supply from building power. Wait several minutes to ensure all power supplied have discharged.
11. Reconnect the green HV connectors to the HV modules.
12. Connect the Positive HV output to an appropriate load and attach a measuring device. A grounded Fluke 80K-40 high voltage probe (or similar) attached to a DMM will work for this process. **If no such probe is available, do not proceed.**
13. Plug in and power on the supply.
14. Enable and engage high voltage output and record the output potential (both on the screen and on the multimeter).
15. Change through a series of HV outputs and record the output potential to ensure accuracy on both HV modules.



### Software edits

Depending on the maximum output of the high voltage power supply used, some edits within the Arduino software may be required for correct operation. These editable items are described in the code and found at lines 91, 92, and 93. Line 91 should be edited for any supply with a maximum output potential other than  $\pm 20$  kV. Line 92 may be edited to alter the ramp rate of the power supply; higher values will ramp the supply faster, with 4096 removing the ramping feature entirely. Line 93 may be edited for older Arduino units as the EEPROM memory ages and becomes unstable after 100,000 uses. Edit in multiples of 8 to set to a new memory block within the EEPROM.

### Software troubleshooting

If the DAC is reading correctly per the test outlined above but the output is not what is expected, uncomment line 413. After uploading the software, the HV Ramp Up screen will now report the DAC output setting below the potential output. The system may be operated normally with this line uncommented, but it is suggested to disconnect the HV modules and test the output from the DAC in this mode to ensure it matches the desired output from the setting shown in the HV Ramp Up screen.

### Operation instructions

**Safety Warning:** Exercise extreme caution when operating and working around the high-voltage (HV) power supply system, especially during assembly and with the cover removed. Be vigilant regarding the voltage potentials used and the current the unit can produce. Establish appropriate safety controls to shield the system during construction and operation. Always dissipate any residual voltages through an appropriate load to ground before servicing.

During assembly, care must be taken to always maintain the system in an off state. Follow the assembly instructions as provided to minimize possibility of electrical shock during assembly. Always work with another person in case an emergency occurs and stand on an insulating pad. Work one handed when possible and sink all components to ground after unplugging prior to maintenance to ensure operator safety.

During operation, with the cover closed, no high voltages are present outside of the grounded box. However, rear ports do allow access, with appropriate connectors, to both positive and negative HV potentials. Appropriate precautions should be taken regarding connecting this device to the unit to be controlled and appropriate shielding should be in place prior to operation. The rapid shutdown switch is positioned on the front of the HV unit to immediately close the internal relays to bring control potentials to zero as quickly as the supply module may sink the potential through the external load.

Assembly of this supply as detailed above requires knowledge in basic circuits, soldering, high voltage safety, and basic metal working experience and tooling.

### Operation

Connect the power supply unit to the external device to be powered from one of the two rear connectors prior to powering on the unit. Ensure the HV enabled switch is set to disabled and the polarity switch is set to the desired polarity. After powering on, the front screen should display as shown in Fig. 6 (all figures demonstrated with Negative mode active).

From the main screen, all user-operated controls may be selected by rotating the rotary encoder to select options 1–3. Option 1 will ramp the applied potential from zero to HV setting at the ramp rate selected in the setup process described above if selected while HV STATUS is in the OFF state. If selected when HV STATUS is in the ON state, the system will ramp the potential down from HV Setting to zero volts. Fig. 7 demonstrates the screens displayed through this process. If HV On is selected while the system is in DISABLED mode (front switch is in the disabled position), an error message will be displayed to the user for 5 s to change front panel switch to enable HV output before returning to the home screen.

If Option 2 is selected (Set Voltage), the screen will display as shown in Fig. 8. From this screen, the prior setting is displayed at the top and the cursor will begin blinking in the “ones” place on the screen. Rotating the encoder will change these values from 0 to 9 for a given space. Clicking the encoder moves between spaces and will cycle until “BACK” is selected. At this point, the user may rotate the encoder between BACK, OK, and CANCEL and clicking the encoder button will select the highlighted option. BACK will return to the “ones” place where the potential may be set if a mistake was made. CANCEL will return the user to the main screen without altering the HV setting. Finally, OK will save the new setting to the EEPROM of the device, after which one of three options may occur. (1) if HV is OFF or DISABLED, the user will be returned to the main screen with the new HV setting displayed. (2) if HV is ON and the new potential is higher than the previous setting, the HV ramp up screen will be displayed until the new setting has been established. Finally, (3) if HV is ON and the new potential is lower than the previous setting, the HV ramp down screen will be displayed until the new setting has been established.

### Front panel options

There are four controls accessible to the user on the front panel (besides the main power switch). These include the rotary encoder and its use as described above. Also included are the HV enable switch, the polarity switch, and the latching rapid

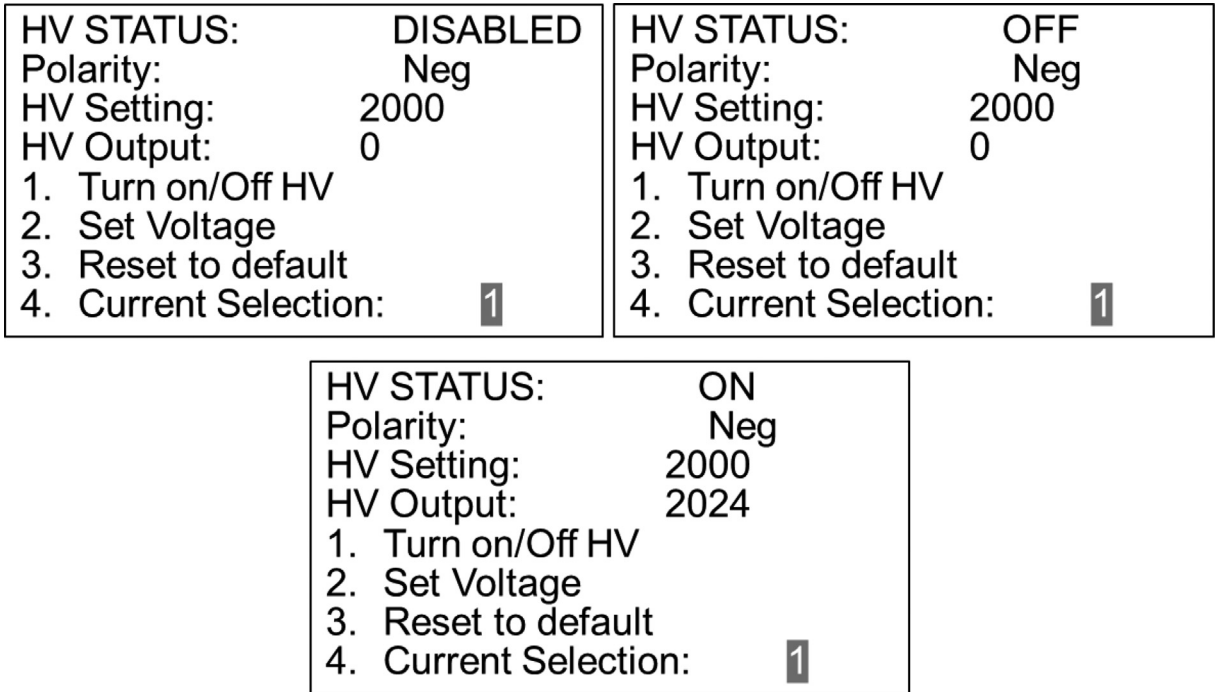

Fig. 6. Home screen of HV power supply when potential output is disabled (top left), enabled and off (top right), and active (bottom).

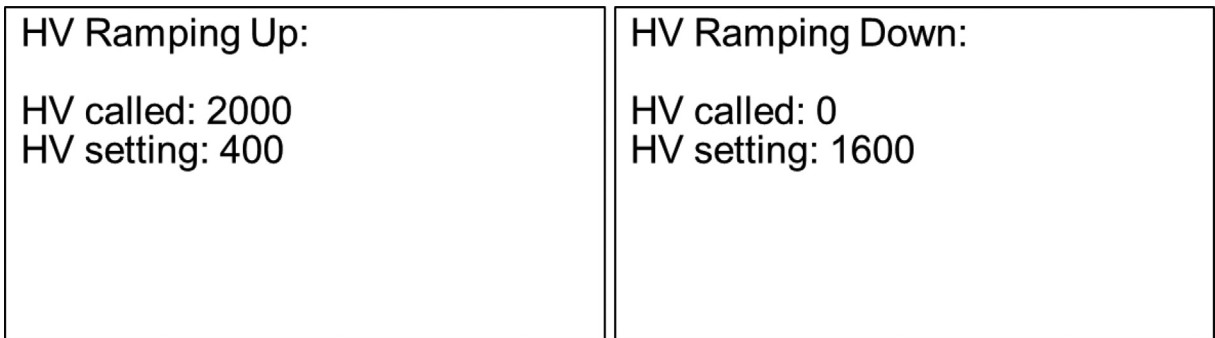

Fig. 7. High Voltage ramping (up or down) user displays. In each mode, the HV setting is what is currently being sent to the power supplies while HV called is the final setting desired through the given mode. The ramp rate is determined by steps per second as set in the setup process. These screens are also utilized if HV settings are changed while output is engaged.

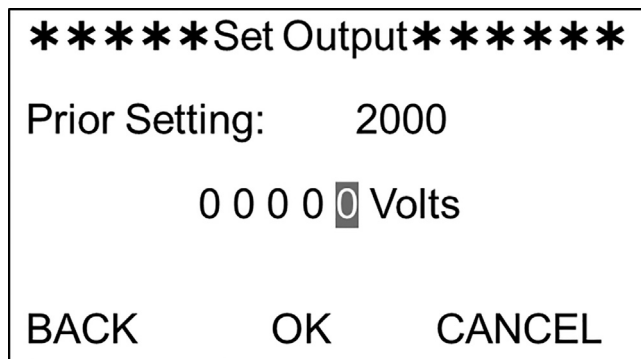

Fig. 8. HV setting display screen. When numbers are selected, rotating the encoder will cycle the numbers between 0 and 9 and clicking will advance to the next number. When BACK is highlighted, rotating the encoder will change between selecting BACK, OK, or CANCEL and clicking will select the highlighted option.

shutdown button. The use of the HV enable switch as it related to the main screen is described above. However, if this switch is switched from enabled to disabled while the high voltage is active, the system will automatically switch into HV ramp down mode and reduce all potentials to 0 V before disabling the system at the relays as a safety mechanism. Note that this is a controlled ramp-down procedure, not a rapid shutdown for safety.

If at any time, the user presses the Rapid Shutdown button on the front panel, the system will immediately close both relays and display the screen demonstrated in Fig. 9. The internal HV will also be set to the OFF state via both relays shunting to State 2 and driving the HV module adjust pins to ground. This will immediately cause the power supply to sink current at the highest rate possible from the load. Such use may reduce the lifespan of the high voltage supply or damage connected equipment and so should not be used for routine shutdowns. The screen shown in Fig. 8 will remain until the switch is pressed again, after which the software will undergo a full reset, ensuring user safety.

The polarity switch allows user selection of the power supply used for HV output. This switch may be changed at any time during operation. If HV output is OFF, changing the polarity switch will only result in changing the main screen between "NEG" and "POS" displays and the illumination of the appropriate LED's on the front and back of the unit. If HV output is on when this switch changed, HV ramp down is called and the potential reduced to zero on the output line before the polarity light indicators are changed to inform the user when it is safe to work with the attached equipment.

**Validation and characterization**

Operation of the HV power supply was confirmed through direct measurement of the output through a Fluke 80 K-40 HV probe (Fig. 10) and application of the supply to an Ion Mobility Spectrometry cell requiring a steady potential of ± 10 kV on the first ring for normal operations (Fig. 11). The modular HV supply was compared to a commercially available power supply (XP Power, Sunnyvale CA, FJ20R040) operated via front-panel controls.

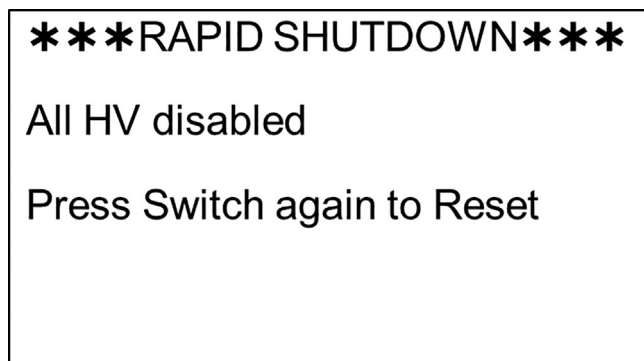

Fig. 9. Rapid Shutdown mode user screen display.

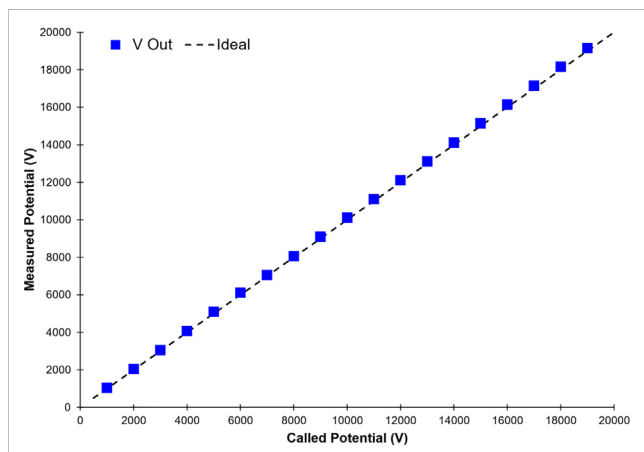
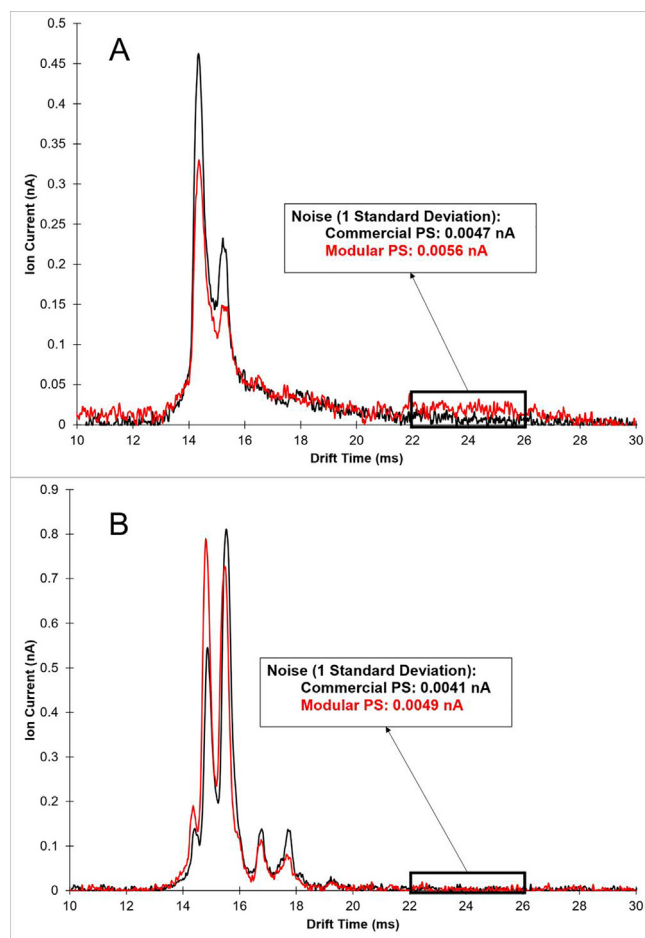

Fig. 10. Measured vs Called potential for negative power supply module in HV power supply. Black trace indicates 1:1 ideal. The maximum deviation from ideal is <100 V relative to Earth ground, within the ±0.5 % load regulation parameters of the HV module.



**Fig. 11.** Ion Mobility spectra in the positive (A) and negative (B) modes. Black traces were obtained with an XP Power FJ20R040 supply, Red traces with the supply as described. Both the commercial and custom supplies provided sufficient and stable potentials to obtain consistent IMS spectra, though the custom supply did demonstrate slightly higher levels of background noise. (For interpretation of the references to color in this figure legend, the reader is referred to the web version of this article.)

When operated with 1000 V increments, the supply demonstrated an average accuracy of  $\pm 1.3\%$  across the range of the supply, within the combined errors of the dependent devices (Arduino, MCP4725, LM2596, 24 V supply, etc.). The greatest deviations occurred at the extreme ends of the requested curve (highest and lowest voltages), consistent with the stated limitations of the MCP4725 board used for DAC control. This resulted in a linear correlation to called vs output (Fig. 10) with an  $R^2$  of 0.999994. This supply was also maintained at 20 kV (supply maximum) for 24 h, demonstrating a standard deviation of  $\pm 15$  V (0.07 %) when measured to 0.01 V at a 2 Hz sampling rate. Data demonstrated in Fig. 10 were obtained from the negative power supply and are displayed as absolute value for clarity.

Fig. 11 demonstrates the recorded IMS spectrum for the positive mode (A) and negative mode (B) 50 average reactant ion peaks for a corona discharge ionization (CDI) source biased at 3.5 kV above the first ring. In IMS, reactant ions are always present and multiple peaks for a CDI source are not uncommon. A standard deviation of the baseline was obtained across a 2 ms range where no peaks were observed for direct comparison between the commercial and built power supplies. For both positive and negative modes, the noise level was slightly higher for the modular supply than the commercial supplies. However, general peak shapes, resolution, and drift times were identical, demonstrating a consistent, stable output across the averages obtained. It should be noted that variances in relative peak heights for reactant ions from a CDI source in IMS are variable within a short period depending on humidity, pressure, and temperature, so the different peak heights demonstrated in this data are not due to differences between the power supplies used but between the time required to transition the instrument between HV supply sources and obtain the displayed data.

It should also be noted that while the XP Power supplies are sold as reversible high voltage supplies, changing potential is a tedious process involving swapping entire internal modules. This process requires approximately 30 min to complete. The ability to rapidly change polarities as provided by the described supply is highly advantageous when working with samples that require both polarities. Finally, while some commercial supplies do ramp potentials, many commercial supplies either

do not provide this functionality or will only ramp up in potential. As IMS relies upon a series of highly sensitive electronics attached to the HV portion of the instrument, a moderated ramp is desired for turning the instrument on and off to protect these devices.

### Capabilities:

- Flexible, stable high-voltage output in both the positive and negative modes.
- Rapid switching between polarities via a front-panel switch (though a cable change is required)
- Ramp up and Ramp down of high voltage potentials to protect attached equipment.
- Rapid shutdown mode allows rapid discharge of applied potentials to protect the user and equipment.

### Limitations:

- DAC 12-bit resolution limits the minimum potential difference between settings to 4.88 V (assuming a 20 kV HV module).
- Output potential demonstrates slightly higher noise levels than commercially-available power supplies.
- Output limited to 1 mA current

### CRedit authorship contribution statement

**Eric J. Davis:** Software, Validation, Writing – original draft, Visualization, Funding acquisition. **Brian H. Clowers:** Conceptualization, Writing – review & editing, Funding acquisition, Validation.

### Declaration of Competing Interest

The authors declare that they have no known competing financial interests or personal relationships that could have appeared to influence the work reported in this paper.

### Acknowledgments

Funding: This work was supported in part by the M.J. Murdock Charitable Trust and the Whitworth Summer Fellowship Program. Contributions from BHC were supported by the NSF 2003042.

### Appendix A. Supplementary data

Supplementary data to this article can be found online at <https://doi.org/10.1016/j.ohx.2022.e00382>.

### References

- [1] S. Armenta, M. Blanco, Ion mobility spectrometry: a comprehensive and versatile tool for occupational pharmaceutical exposure assessment, *Anal Chem.* 84 (10) (2012) 4560–4568.
- [2] K.M. Roscioli, E. Davis, W.F. Siems, A. Mariano, W. Su, S.K. Guharay, H.H. Hill, Modular ion mobility spectrometer for explosives detection using corona ionization, *Anal. Chem.* 83 (15) (2011) 5965–5971.
- [3] T. Reinecke, B.H. Clowers, Implementation of a flexible, open-source platform for ion mobility spectrometry, *HardwareX.* 4 (2018) e00030.
- [4] M.L. Poltash, J.W. McCabe, M. Shirzadeh, A. Laganowsky, B.H. Clowers, D.H. Russell, Fourier transform-ion mobility-Orbitrap mass spectrometer: a next-generation instrument for native mass spectrometry, *Anal. Chem.* 90 (2018) 10472–10478, <https://doi.org/10.1021/acs.analchem.8b02463>.
- [5] A. Bohnhorst, A.T. Kirk, S. Zimmermann, Simulation aided design of a low cost ion mobility spectrometer based on printed circuit boards, *Int. J. Ion Mobil. Spec.* 19 (2016) 167–174, <https://doi.org/10.1007/s12127-016-0202-7>.
- [6] H.H. Hill Jr., W.F. Siems, R.H. St. Louis, Ion Mobility Spectrometry, *Analytical Chemistry.* 62 (1990) 1201A-1209A. doi: 10.1021/ac00222a001.
- [7] A.B. Kanu, P. Dwivedi, M. Tam, L. Matz, H.H. Hill, Ion mobility-mass spectrometry, *J. Mass Spectrometry.* 43 (1) (2008) 1–22.
- [8] R.G. Ewing, D.A. Atkinson, G.A. Eiceman, G.J. Ewing, A critical review of ion mobility spectrometry for the detection of explosives and explosive related compounds, *Talanta* 54 (2001) 515–529, [https://doi.org/10.1016/S0039-9140\(00\)00565-8](https://doi.org/10.1016/S0039-9140(00)00565-8).
- [9] J. Almirall, P. Diaz-Guerra, H. Holness, K. Furton, Field Detection of Drugs and Explosives by SPME-IMS, US Department of Justice, 2012.
- [10] T. Keller, A. Schneider, E. Tutsch-Bauer, J. Jaspers, R. Aderjan, G. Skopp, Ion mobility spectrometry for the detection of drugs in cases of forensic and criminalistic relevance, *Int. J. Ion Mobility Spectrometry* 1 (1999) 22–34, <https://doi.org/10.1016/j.forsciint.2006.03.032>.
- [11] A.B. Kanu, P.E. Haigh, H.H. Hill, Surface detection of chemical warfare agent simulants and degradation products, *Anal. Chim. Acta* 553 (2005) 148–159, <https://doi.org/10.1016/j.aca.2005.08.012>.
- [12] E.J. Davis, K.F. Grows, W.F. Siems, H.H. Hill, Electrospray ionization-voltage sweep-Ion mobility spectrometry for biomolecules and complex samples, *Int. J. Ion Mobil. Spec.* 17 (3-4) (2014) 147–156.
- [13] W.F. Siems, C. Wu, E.E. Tarver, H.H.J. Hill, Measuring the resolving power of ion mobility spectrometers, *Anal. Chem.* 66 (23) (1994) 4195–4201.
- [14] W. Baether, S. Zimmermann, F. Gunzer, Investigation of the influence of voltage parameters on decay times in an ion mobility spectrometer with a pulsed non-radioactive electron source, *Int. J. Ion Mobility Spectrometry* 13 (2010) 95–101, <https://doi.org/10.1007/s12127-010-0046-5>.
- [15] T. Reinecke, A.L. Davis, B.H. Clowers, Determination of gas-phase ion mobility coefficients using voltage sweep multiplexing, *J. Am. Soc. Mass Spectrom.* 30 (2019) 977–986, <https://doi.org/10.1007/s13361-019-02182-x>.
- [16] C.-P. Shih, K.-C. Yu, H.-T. Ou, P.L. Urban, Portable pen-probe analyzer based on ion mobility spectrometry for in situ analysis of volatile organic compounds emanating from surfaces and wireless transmission of the acquired spectra, *Anal. Chem.* 93 (2021) 2424–2432, <https://doi.org/10.1021/acs.analchem.0c04369>.

- [17] K. Giles, J. Ujma, J. Wildgoose, S. Pringle, K. Richardson, D. Langridge, M. Green, A cyclic ion mobility-mass spectrometry system, *Anal. Chem.* 91 (2019) 8564–8573, <https://doi.org/10.1021/acs.analchem.9b01838>.
- [18] A. Ahrens, J. Möhle, M. Hitzemann, S. Zimmermann, Novel ion drift tube for high-performance ion mobility spectrometers based on a composite material, *Int. J. Ion Mobil. Spec.* 23 (2020) 75–81, <https://doi.org/10.1007/s12127-020-00265-0>.
- [19] A. Hollerbach, C.R. Conant, G. Nagy, Y.M. Ibrahim, Implementation of ion mobility spectrometry-based separations in structures for lossless ion manipulations (SLIM), *Methods Mol Biol.* 2394 (2022) 453–469, [https://doi.org/10.1007/978-1-0716-1811-0\\_23](https://doi.org/10.1007/978-1-0716-1811-0_23).
- [20] R. Wojcik, G. Nagy, K. Isaac, I.K. Attah, S.V.B. Webb, K.K. Garimella, A. Weitz, M.E. Hollerbach, M.R. Monroe, F.F. Ligare, R.V. Nielson, R.S. Norheim, T.O. Renslow, Y.M. Metz, R.D.S. Ibrahim, SLIM ultrahigh resolution ion mobility spectrometry separations of isotopologues and isotopomers reveal mobility shifts due to mass distribution changes, *Anal. Chem.* 91 (2019) 11952–11962, <https://doi.org/10.1021/acs.analchem.9b02808>.
- [21] High Voltage Safety, Safety. (n.d.). <https://safety.ep.wisc.edu/hazards/high-voltage-safety> (accessed October 14, 2022).



Eric J. Davis, Ph.D. is an Associate Professor of Chemistry at Whitworth University in Spokane, WA, focusing on the development of Ion Mobility Spectrometry in an undergraduate research environment, where he has been on faculty since 2019. Prior to joining Whitworth University, he was a faculty member with Azusa Pacific University, Azusa, CA, from 2015–2019 and Fresno Pacific University, Fresno, CA, from 2012–2015. Eric is the author of 18 peer-reviewed articles and 1 patent. He holds a BS in biochemistry from the University of Portland and a Ph.D. in Instrumental Chemistry under Dr. Herbert Hill at Washington State University, Pullman, WA, in 2012 with his dissertation titled: “Novel Instrumental Approaches to Ion Mobility Spectrometry: High-Pressure, Voltage-Sweep, and Radiative-Ion-Ion-Recombination.” His research has been funded by the National Science Foundation and the Murdock Trust. He lives in Spokane, WA with his wife and four children.



Brian H. Clowers, Ph.D. is an Associate Professor of Chemistry at Washington State University focusing on the fundamentals, development, and application of rapid gas-phase separations techniques with an emphasis on ion mobility and mass spectrometry in support of molecular ‘omics campaigns. Prior to joining WSU as an Assistant Professor of Chemistry in 2013, Brian worked for the National Security Directorate at the Pacific Northwest National Laboratory (PNNL) where he was part of an interdisciplinary team focusing on forensic challenges across the threat spectrum. Recently promoted to the rank of Associate Professor, Clowers is the author of over 85 peer-reviewed articles, 7 patents, and 1 book chapter. He holds a BS in chemistry from the University of Nevada, Reno and a Ph.D. in chemistry from Washington State University (2005). Clowers has also served as a post-doctoral fellow at the University of California, Davis and PNNL and currently serves as a scientific advisor for PNNL’s internal research endeavors. Additional service commitments include membership on the Editorial Advisory Committee for the *Journal of the American Society for Mass Spectrometry* and instructor for the short courses on ion mobility spectrometry at the annual conferences for the American Society for Mass Spectrometry and the International Society for Ion Mobility Spectrometry.