

Dissecting 3D Printing for Engineering Design Process Education of High School Preservice Teachers

Abstract

3D printing (3DP) has been becoming more and more popular throughout the education system from Kindergarten to University. High school is a critical period for students to decide their imminent university major selection which in turn will impact their future career choices. High school students are usually intrigued by hands-on tool such as 3DP which is also an important contributor to other courses such as robotics. The recent years have seen more investment and availability of 3DP in high schools, especially Career and Technical Education (CTE) programs. However, mere availability of 3DP is not enough for teachers to fully utilize its potential in their classrooms. While basic 3DP skills can be obtained through a few hours of training, the basic training is insufficient to ensure effective teaching Engineering Design Process (EDP) at the high school level. To address this problem, this project develops an EDP course tightly integrated with 3DP for preservice teachers (PST) who are going to enter the workforce in high schools. Engineering design process (EDP) has become an essential part for preservice teachers (PST), especially for high school STEM. 3DP brought transformative change to EDP which is an iterative process that needs virtual/physical prototyping. The new PST course on EDP will be purposefully integrated with an in-depth discussion of 3DP. The approach is to dissect a 3D printer's hardware, explain each component's function, introduce each component's manufacturing methods, describe possible defects, and elucidate what works and what does not. This has at least four benefits: 1) PSTs will know what is possibly wrong when a printer or printing process fails, 2) PSTs will learn more manufacturing processes besides 3DP that can be used to support engineering design prototyping, 3) PSTs will know how to design something that can meet the manufacturing constraints, i.e., can be actually fabricated, and 4) reduce errors and frustrations caused by failed design and failed prints which happen frequently to novices in 3DP. After graduation, PSTs will bring the knowledge to their future high schools and will be more confident in teaching engineering design, reverse engineering, prototype development, manufacturing, and technology. The developed course will be implemented and assessed in a future semester.

Keywords: Preservice teacher education, engineering design process, 3D printing

1. Introduction

Engineering Design Process (EDP) is an integral component of what engineers do and how they approach societal problems. The National Center for Engineering and Technology Education (Hynes, et al., 2021) defined EDP as an approach inclusive of defining a problem and developing a model to be refined through data analysis to produce a solution consisting of technological and social elements (Daugherty & Custer, 2012). 3D printing (3DP) can provide critical and timely prototype needs in EDP, offering “the greatest potential for applying science knowledge in the classroom and engaging in engineering practices” (National Research Council, 2012), pp. 201–202). 3DP is a kind of Additive Manufacturing (AM), but is often used interchangeably with AM.

3DP has been becoming more and more popular throughout the education system from Kindergarten to University. High school is a critical period for students to decide their imminent university major selection which in turn will impact their future career choices. High school students are usually intrigued by hands-on tool such as 3DP which is also an important contributor to other courses such as robotics.

The recent years have seen more investment and availability of 3DP in high schools, especially Career and Technical Education (CTE) programs. However, mere availability of 3DP is not enough for teachers to fully utilize its potential in their classrooms. While basic 3DP skills can be obtained through a few hours of training, the basic training is insufficient to ensure effective teaching EDP at the high school level. To address this problem, this project develops an EDP course tightly integrated with 3DP for preservice teachers (PST) who are going to enter the workforce in high schools.

The rest of the paper is organized as follows. Section 2 is the literature review. Section 3 elaborates the course structure, example course contents, and pedagogy. Section 4 is the conclusion and future work.

2. Literature Review on Engineering Design, 3D Printing in Education, and Pedagogy

Engineering and technology relate to the applications of science, and they offer students a path to strengthen their understanding of the role of sciences. *EDP* is a common series of steps that engineers use in creating functional products. It often needs to be repeated many times as needed and design improvements are made as engineers learn from failure. Virtual and/or physical prototypes need to be made with various manufacturing processes, many of which may not be accessible to K-12 teachers and students. The rise of *3DP* brought transformative changes to this situation. It allows a person with limited fabrication lab access to be able to generate physical prototypes too.

Engineering design has become an essential part for STEM PST, especially for high schools. The 2018 report “Strategy for American Leadership in Advanced Manufacturing” of the National Science & Technology Council, published by the Executive Office of the President of the United States, recommended that “specific attention should be applied to curricula in additive manufacturing, computer-aided design, and engineering” (National Science & Technology Council, 2018). While 3DP is great, a person without proper training will not be able to use a 3DP effectively. To make 3DP an effective tool for supporting EDP, it is necessary to provide aspiring teachers with sufficient training.

Technological Pedagogical and Content Knowledge (TPACK): 3DP has been used in various disciplines to visualize the science concepts (Papavlasopoulou, Giannakos, & Jaccheri, 2017), most notably in the maker movement. Several studies in East Asia introduced 3DP to PSTs and developed a TPACK-based curriculum (Sullivan & McCartney, 2017; Yi, Park, & Lee, 2016; Song, 2018). The TPACK framework transcends the three individual components of *content*, *pedagogy*, and *technology* (**Figure 1**) (Mishra & Koehler, 2006). As shown in **Figure 1**, TPACK has **seven components**: TK, PK, CK, TPK, TCK, PCK, and TPCK. The framework argued that developing teachers’ TPCK should be an important consideration in the teacher development programs concerned with enabling teachers to instruct effectively with technology (So, 2013). The TPACK framework advocates ‘*learning by design*’ and suggests when teachers are aware of how

to use 3DP and how to effectively integrate such technology into the curriculum, students can actively learn through their use. Chai and Koh (2017) proposed the Scaffolded TPACK Lesson Design Model (STLDM) to change teachers' TPACK and design beliefs (Chai & Koh, 2017).

Nationwide, the National Research Council has developed new engineering and technology standards that have recently become part of the K-12 curriculum at a national level, NGSS (National Research Council, 2012). **3DP** is directly aligned with the Framework for K-12 STEM Education (Quinn & Bell, 2013). It can engage students in practices that intersect engineering, technology, and applications of science, thus addressing the NGSS objective to strengthen “the science education provided to K-12 students by making the connection between engineering, technology, and applications of science” (National Research Council, 2012). NGSS has been adopted by 20 states, but not including Texas where Houston is located. In Texas, Texas Essential Knowledge and Skills (TEKS) has stipulated detailed standards in STEM.

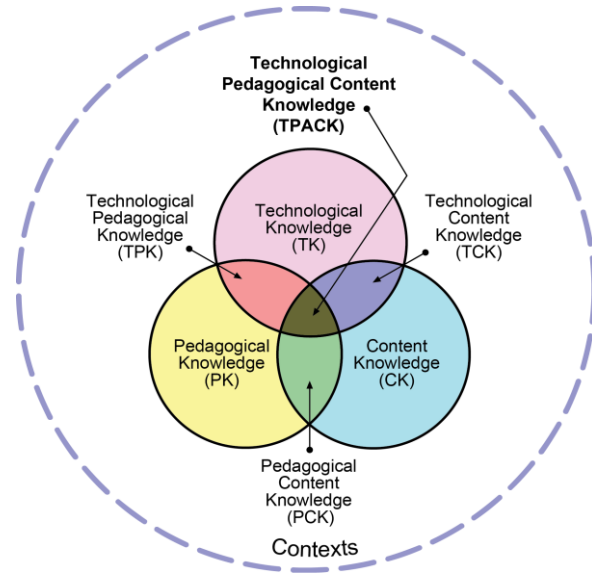

Figure 1. TPACK Model

Problem-based Learning with POGIL Methodology (Figure 2):

In higher education, concepts such as “self-directed learning,” “inquiry based learning,” “experiential learning,” “service learning,” “project-based service learning,” “active learning,” CDIO (Conceive, Design, Implement and Operate), “problem-based learning” and “project-based learning” were introduced in the decades after the World War II (Kolmos & de Graaff, 2014). These learning concepts come under the umbrella of *learner-centered learning* models. There is a wide variety of implementation of problem-based learning and project-based learning (both known as PBL) in engineering education (Beddoes, Jesiek, & Borrego, 2010).

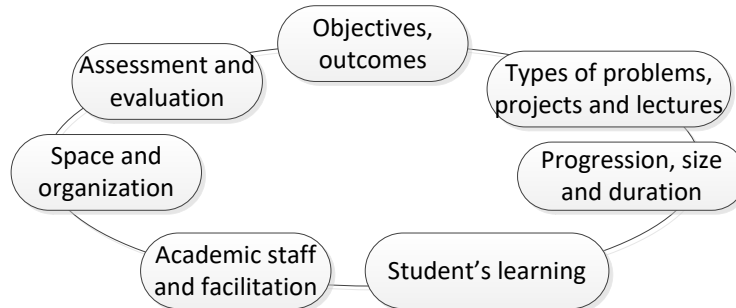

Figure 2. Seven Elements of PBL Curriculum Model

POGIL (Process Oriented Guided Inquiry Learning) embodies *active learning* and *PBL* (Figure 4) (Process Oriented Guided Inquiry Learning, 2022) (Elliot & Chiu, 2013). POGIL uses guided inquiry to not only improve student learning outcomes but also help with the development of important student skills in information processing, critical thinking, problem solving, teamwork, and communication. To improve student self-regulation, POGIL uses PBL so that learning may occur through an instructional scaffolding approach.

3. Dissecting 3D Printing to Teach Engineering Design Process

We followed the STLDM to design modules and integrate them into the CUIIN 4397 Engineering Design and Technology course in the teachHOUSTON program at University of Houston (teachHOUSTON, 2022). STLDM consists of a two-stage design process: 1) the first stage focuses on the formulation of the learning objectives; 2) the second stage focuses on selecting the pedagogical means to achieve the objectives (Chai & Koh, 2017).

Engineering design process (EDP) has become an essential part for preservice teachers (PST), especially for high school STEM. 3DP brought transformative change to EDP which is an iterative process that needs virtual/physical prototyping. The new PST course on EDP will be purposefully integrated with an in-depth discussion of 3DP. We are developing a new PST course on EDP which tightly integrates with an in-depth discussion of 3DP. Our innovative approach is to dissect a 3D printer's hardware, explain each component's function, introduce each component's manufacturing methods, describe possible defects, and elucidate what works and what does not.

Table 1 outlines the four course modules in *Tasks 1 and 2*, in terms of TPACK. There are four modules in this course. The details are as follows.

3.1 Module I: Introduction to EDP with Reverse Engineering.

Working in teams of three to four, teachers are asked to conduct interviews and surveys to generate a customer needs analysis for a consumer product. The customer needs matrix is utilized to inform the implications for redesign. Teams sketch predicted internal structures of the products, disassemble the product, and compare to their prediction. Functional models and activity diagrams are created to gain a deeper understanding of how the product functions.

Table 1 CUIIN 4397 TPACK-based Course Module Development Summary

#	Hrs	Contents	Key Information	TPACK
I	6	Engineering design process	Reverse Engineering of a product; customer needs matrix; sketch; functional models; activity diagrams	CK,PC K, TK
II	9	Part 1: 3DP dissection and reverse engineering	Disassemble a 3D printer and identify components, materials, and their manufacturing methods	TCK
	3	Part 2: 3DP operation	3D printing process, G code, STL, slicer	TK
	6	Part 2: 3D modeling	SolidWorks Apps for Kids; open source models	TK,CK
	3	Part 2: 3DP troubleshooting	Print quality, calibration, post-processing, maintenance	TK
II I	6	Invention design challenge	Each group prototype an innovation using 3D printed parts and standard components that can be purchased	PK,PCK TPK
IV	12	Curricular development	Preservice teachers' own lesson plans	TPCK

3.2 Module II: 3D Printing

3.2.1 Part I of Module II

For *Part I* of Module II, each PST group will start with assembling a 3D printer, load a model in software controller, print a model, and clean up. This allows the teachers to understand how 3D printing works. After this, we will start to explain its machine elements and manufacturing methods by dissecting and referring to 3D printer components. During the hands-on learning process, each group will disassemble and assemble various parts of 3D printers as a reverse engineering approach to gain a deeper understanding.

Among the consumer 3DP, the most common type is Fused Deposition Modeling (FDM) which uses plastic filament as the raw material. In our course module development, we focus on FDM printer because: 1) it contains many typical mechanical machine elements; 2) it is easier and safer to maintain and operate; and 3) it is most popular and affordable in K-12. (**Figure 3**). We identified the major machine elements of a FDM 3DP (**Table 2**) (Groover, Introduction to Manufacturing Processes, 2011; Groover, Fundamentals of Modern Manufacturing: Materials, Processes, and Systems, 2015).

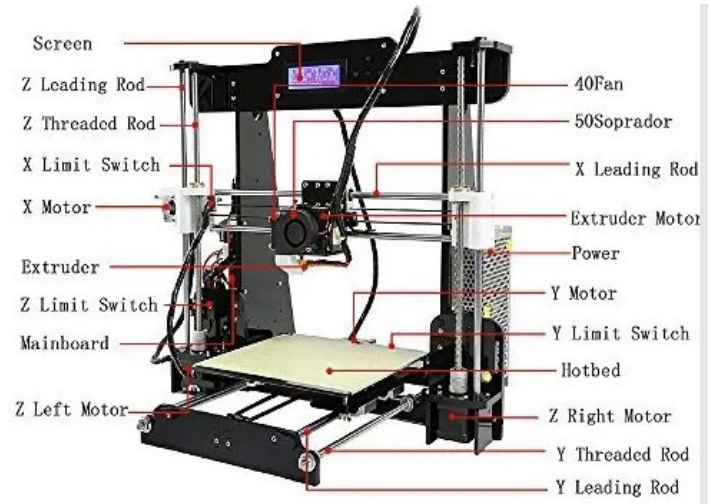

Figure 3. A FDM Printer with Components

Table 2 Machine Elements from the 3D Printer Hardware

No	Components	Materials and/or Machine Elements	Manufacturing Processes
1	Plastic filament	Polymer materials	Plastics extrusion
2	Aluminum frame	Aluminum bar	Bulk deformation
3	Heated bed	Aluminum sheet metal	Sheet metal working
4	Belt and pulley	Belt and pulley standard	Rubber, casting / machining
5	Spring	Spring standard	Winding
6	Bearing	Bearing standard	Heat treatment, sheet metal
7	Leadscrew rod	Screw standard	Rolling
8	Bolt and nut	Bolt and nut standard	Cutting, forging, heat treatment
9	Nozzle	Rotational part	Machining

We have developed course materials for these machine elements. Given the limited hours in each course module, our target is to present the most useful information to the PSTs (undergraduate students who may not necessarily have the background in engineering or technology) with concise description. It is not our intention to write a comprehensive tutorial or textbook on machine

elements which will require one or two semesters of instruction with multiple courses. As an example, below is the excerpt from the section of *Leadscrew Rod*.

A leadscrew rod is a threaded rod that is used to translate rotary motion into linear motion. The thread form (shape of the thread) is designed to allow the lead screw nut to easily move on the leadscrew rod. The most common thread forms found in leadscrew rods can be seen in **Figure 4**.

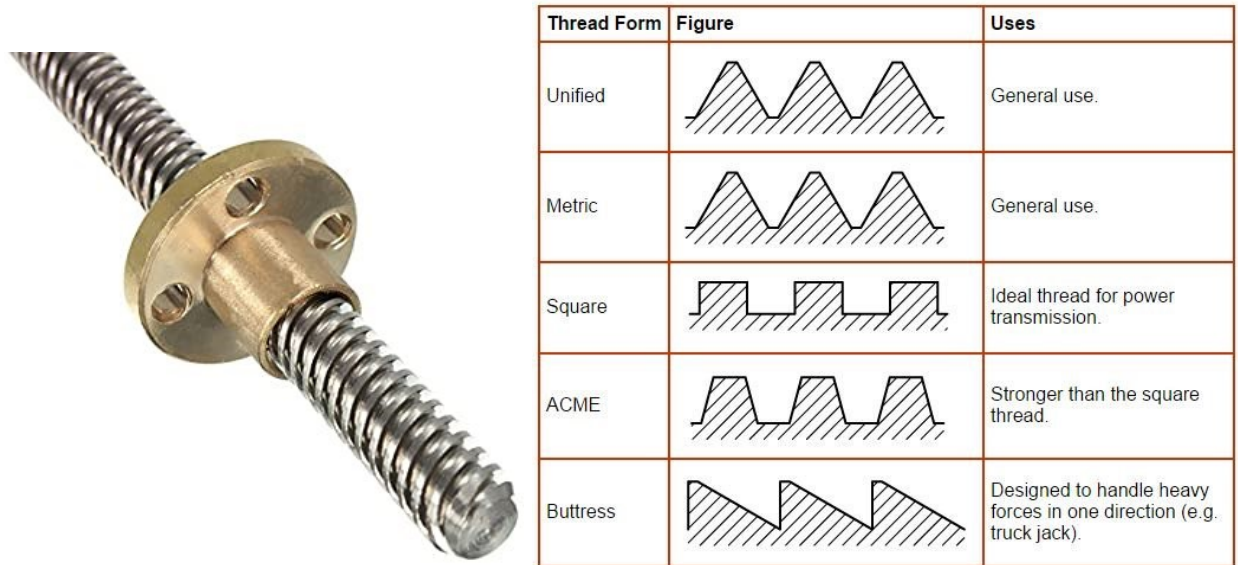

Figure 4. Lead Screw and its typical thread forms

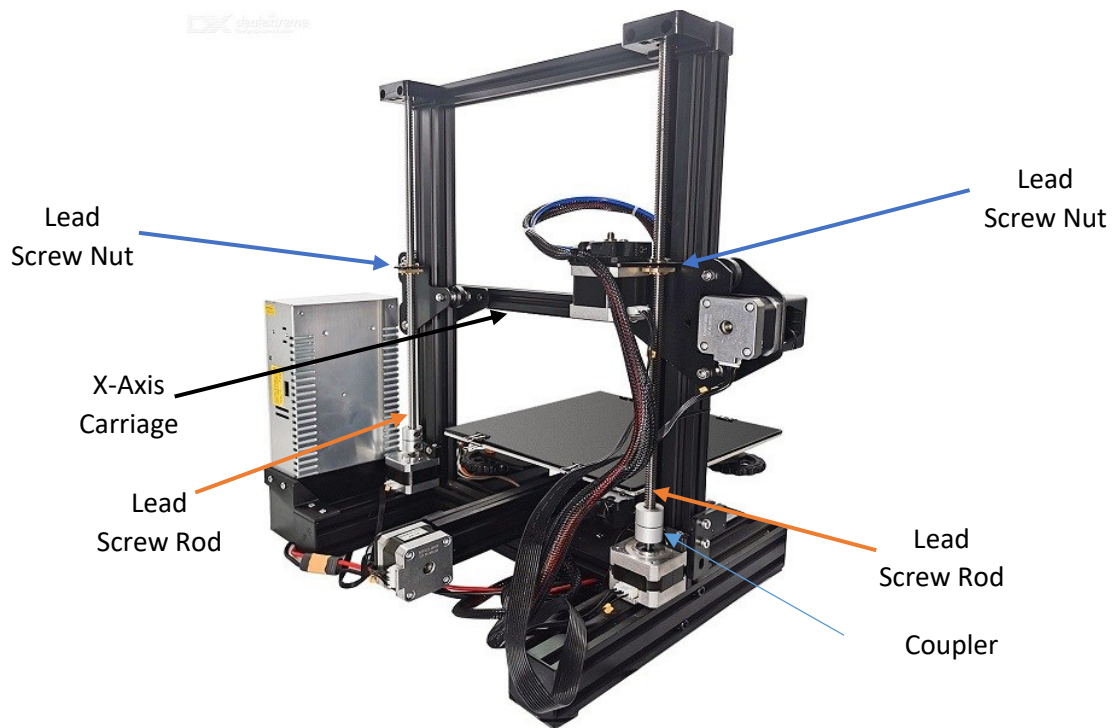

Figure 5. Lead screw rod and nuts

Some advantages of leadscrew rods are that they are a relatively cheaper option when compared to other more expensive power transmission options (such as ball screws). The lead

screw nut does not have any internal components which allows it to run smoothly and quietly. Finally, many lead screws do not backdrive easily. Backdriving is when a force is unwillingly applied to the lead screw rod, resulting in the nut moving on the lead screw unintentionally. An example of this would be the weight of a 3D printer X-axis carriage causing the carriage to slide down the Z-axis lead screw rod (**Figure 5**).

Leadscrew rods are used by 3D printers to transfer the rotary motion of the stepper motors to the linear motion required to move the Z axis. Lead screw rods are widely used in all types of 3D printers at a hobby or professional level and are very reliable so long as they are very straight and not bent. They are generally mated to the stepper motor using a coupler, as seen in **Figure 5**. The most common thread form used in 3D printers is the Metric thread form, also known as the Trapezoidal thread form (**Figure 6**). Figure 6 shows the two main components of the leadscrew rod, spindle and flanged nuts. They come in standard sizes. The most important parameters are diameters and pitch (linear distance travelled with one revolution of threads).

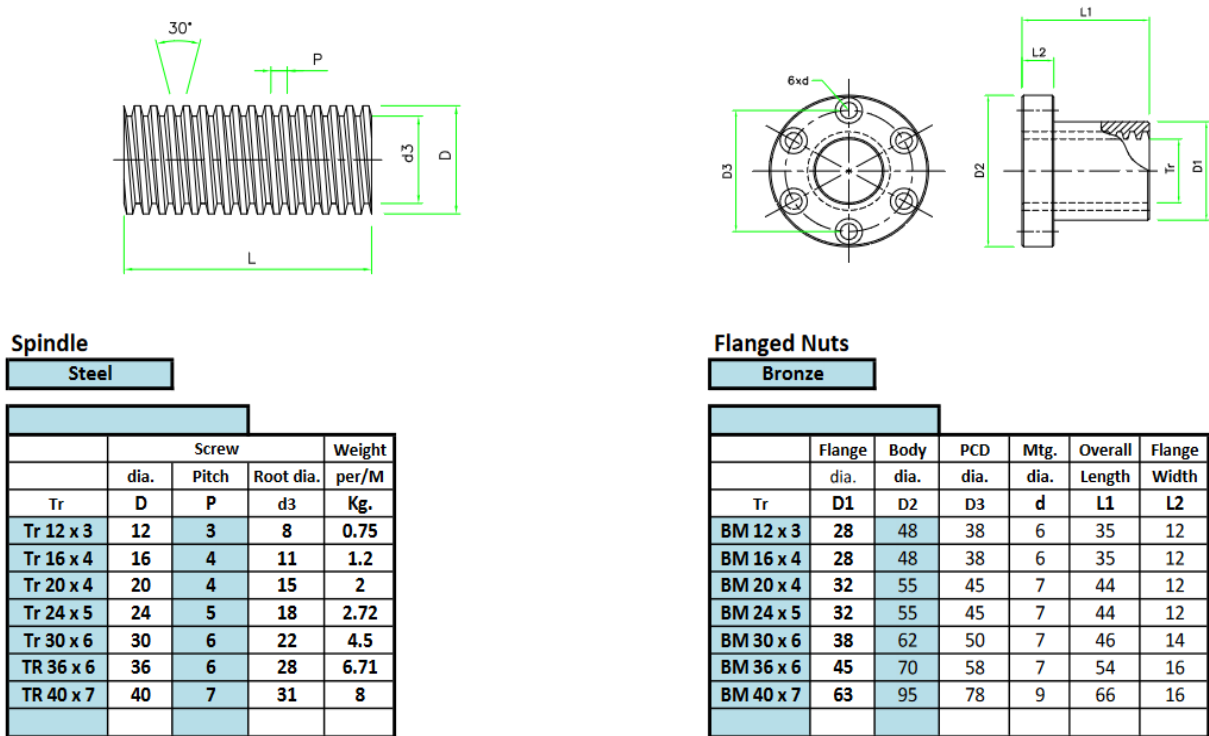

Figure 6. Two components of the leadscrew rod: steel spindle and bronze flanged nuts

3.2.2 Part 2 of Module I

For *Part 2* of Module II: 3D modeling and printing, **POGIL-based PBL** will be used as pedagogy. After explaining the fundamental theory of CAD, a few demos will be provided to explain the whole tool chain. Based on POGIL, with each demo, a series of critical thinking questions will be asked to jump start active learning and activate exploration and what-if analysis. After that, PSTs will be challenged with a series of modeling tasks in TinkerCAD (TinkerCAD, 2022).

3.3 Module III: Invention Design Challenge

PSTs will develop a prototype for an invention selected through guided brainstorming and working knowledge of scientific and mathematical concepts. Examples include prosthetics, assistive technologies, and personal protection equipment (TeachEngineering.org, 2022).

3.4 Module IV: PST Lesson Plan Development

During the final module of course, PSTs will be encouraged to design hands-on activity lesson plans using the EDP. This process builds on the existing pedagogical content knowledge of PSTs and challenges them to explore the novel instructional approaches discussed during the course.

4. Conclusion

This project develops an Engineering Design and Technology course with dissected 3D printing components for PSTs. This innovative approach has multiple benefits: 1) PSTs will know what is possibly wrong when a printer or printing process fails, 2) PSTs will learn more manufacturing processes besides 3DP that can be used to support engineering design prototyping, 3) PSTs will know how to design something that can meet the manufacturing constraints, i.e., can be actually fabricated, and 4) reduce errors and frustrations caused by failed design and failed prints which happen frequently to novices in 3DP. After graduation, PSTs will bring the knowledge to their future high schools and will be more confident in teaching engineering design, reverse engineering, prototype development, manufacturing, and technology. The developed course will be implemented and assessed in the classroom in Fall 2023 semester. It will be first used in the teachHouston program, the flagship teacher education program at University of Houston. After successful implementation and improvement, it will be disseminated to a broader audience.

Acknowledgment

This project is sponsored by the National Science Foundation grant #1855147, #1955036, #2141674, and #2220683. The support is greatly appreciated.

References

- Beddoes, K. D., Jesiek, B. K., & Borrego, M. (2010). Identifying opportunities for collaboration in international engineering education research on problem- and project-based learning. *Interdisciplinary Journal of Problem-based Learning*, 4(2).
- Chai, C., & Koh, J. (2017). Changing teachers' TPACK and design beliefs through the Scaffolded TPACK Lesson Design Model (STLDM). *Learning: Research and Practice*. doi:10.1080/23735082.2017.1360506
- Daugherty, J. L., & Custer, R. L. (2012). Secondary level engineering professional development: Content, pedagogy, and challenges. *International Journal of Technology and Design Education*, 22, 51-64.
- Elliot, D., & Chiu, C.-C. (2013). Implementation of Process Oriented Guided Inquiry Learning (POGIL) in Engineering. *Advances in Engineering Education*, 3(1).
- Groover, M. (2011). *Introduction to Manufacturing Processes* (1st ed.). Wiley.

- Groover, M. (2015). *Fundamentals of Modern Manufacturing: Materials, Processes, and Systems* (6th ed.). Wiley.
- Hynes, M., Portsmore, M., Dare, E., Milto, E., Rogers, C., & Hammer, D. (2021). *Infusing engineering design into high school STEM courses*. Retrieved 2021, from National Center for Engineering and Technology Education: <http://ncete.org/flash/pdfs/Infusing%20Engineering%20Hynes.pdf>
- Kolmos, A., & de Graaff, E. (2014). Problem-based and project-based learning in engineering education. In *Cambridge Handbook of Engineering Education Research*. Cambridge University Press.
- Mishra, P., & Koehler, M. (2006). Technological pedagogical content knowledge: A framework for teacher. *Teachers College Record*, 108(6), 1017-1054.
- National Research Council. (2012). *A Framework for K-12 Science Education: Practices, Crosscutting Concepts, and Core Ideas* (Board on science education, division of behavioral and social sciences and education ed. ed.). Washington, DC: The National Academies Press.
- National Science & Technology Council. (2018). *Strategy for American Leadership in Advanced Manufacturing*. National Science & Technology Council;.
- Papavlasopoulou, S., Giannakos, M., & Jaccheri, L. (2017). Empirical studies on the maker movement, a promising approach to learning: a literature review. *Entertainment Computing*, 18, 57-78.
- Process Oriented Guided Inquiry Learning*. (2022). Retrieved September 2022, from POGIL: <http://pogil.org/>
- Quinn, H., & Bell, P. (2013). How designing, making, and playing relate to the learning goals of K-12 science education. In M. Honey, & D. Kanter, *Design. Make. Play: growing the next generation of STEM innovators*. New York, NY: Routledge.
- So, Y. (2013). Analysis of the Structural Relations between TPACK (Technology, Pedagogy and Content Knowledge), Teaching Efficacy, and Perceived Teaching Professionalism in Primary School Teachers. *Asian Journal of education*, 14(4), 125-147.
- Song, M. (2018). Learning to teach 3D printing in schools: how do teachers in Korea prepare to integrate 3D printing technology into classrooms? *Educational Media International*. doi:10.1080/09523987.2018.1512448
- Sullivan, P., & McCartney, H. (2017). Integrating 3D printing into an early childhood teacher preparation course: Reflections on practice. *Journal of Early Childhood Teacher Education*, 38(1), 39-51.
- TeachEngineering.org. (2022). *Engineering Design Process*. Retrieved 2022, from TeachEngineering.org: <https://www.teachengineering.org/design/designprocess>

teachHOUSTON. (2022). *teachHOUSTON program*. Retrieved from University of Houston:
<https://www.uh.edu/nsm/teachhouston/>

TinkerCAD. (2022). *TinkerCAD*. Retrieved from Autodesk: <https://www.tinkercad.com/>

Yi, S., Park, H., & Lee, Y. (2016). Development of the TPACK-Based Curriculum with 3D Printer for Pre-service Teachers. *The E-Learn: World Conference on E-Learning in Corporate, Government, Healthcare, and Higher Education*. Washington, DC. Retrieved from <https://www.learntechlib.org/p/173978>