

Solar Photovoltaic Generation: Benefits and Operation Challenges in Distribution Networks

Mohammad E. Khodayar, Mohammad Ramin Feizi, Ali Vafamehr

Keywords: Solar PV, Distribution Network Operation and Control

* This work is partially supported by grant ECCS-1710923 National Science Foundation.

1. Introduction

The Solar photovoltaic (PV) generation is a modular electricity generation asset that converts solar energy into electricity. Solar PV units can be manufactured for various applications in different capacities. As the price of solar PV panels decreases with the advancement in technology and the economies of scale, the installed capacity of PV is increased in the transmission and distribution networks. The global PV generation capacity reached 398 GW in 2017 to produce over 460 TWh electricity and to hold about 2% of the global electricity generation [1]. In the U.S., 1.7 gigawatts (GW) of solar PV capacity is installed in the third quarter of 2018 to increase the installed capacity to 60 GW. The total installed capacity of PV generation is expected to be doubled over the next five years; and by 2023, it is estimated that over 14 GW of PV generation capacity will be installed annually [2]. Several challenges in the energy sector were addressed by improving the penetration level of PV generation technology. The greenhouse gas emission due to burning the fossil fuels, the high cost of energy, lack of electricity supply in remote and underdeveloped regions as well as the high transmission and distribution network losses in urban and developed regions are among the challenges that could be addressed by PV generation in the modern global electricity industry. Here, we briefly present these challenges and evaluate the impact of PV generation technology to address them.

1.1. Emission

Greenhouse gas emission is the main driver of climate change. A considerable portion of the emission worldwide is produced in China as it holds the largest carbon footprint in the world since 2004. China is accountable for 27.6% of global carbon dioxide production in 2017 [3] and in order to reduce the carbon footprint, the government is heavily invested in renewable energy resources. Since 2015, China has had the largest installed capacity and power generation of PV and by 2017, 130 GW of solar PV generation is installed with the total capacity projected to be 400 GW by 2030. This effort is further pushed by the National Development & Reform Commission agency in China to increase in the share of renewable energy resources from 20% to 35% by 2030 [4].

In the United States, the considerable source of greenhouse gas emission stems from burning fossil fuels for electricity and transportation. Electricity production has the largest share of greenhouse gas generation after the transportation sector and approximately 68% of the generated electricity is provided by burning fossil fuels including coal and natural gas [5]. Photovoltaic and solar thermal technologies supplied 1% of the total US electricity in 2017 [6]. Solar generation technology contributes to the reduction of the adverse effects of fossil fuel-based generation in the transmission and distribution sectors. It is estimated that typically, solar panels circumvent about 75% of annually grid-related emissions (0.7 tons CO₂/year per kW of solar capacity) in the State of Texas [7].

1.2. Rural Electrification

Access to energy is crucial for industrialization, eradication of poverty and promoting economic growth. About 96% of the global urban population is supplied with electricity; however, merely 77% of the global rural population is electrified [8]. Rural electrification is hindered by slow and costly grid expansions and expensive local generation resources. Two-thirds of the African population, making up about 640 million people, have no access to electricity [9]. Hundreds of millions more are relying on undependable and intermittent energy supply. The demand for electricity to support education and medical facilities is so high across most parts of Africa and the developing world, that many communities and businesses without dependable energy supply are utilizing expensive, polluting and unreliable petroleum-powered generation resources. While a considerable number of projects aim to increase the capacity of the existing electricity grid, such solutions may not seem practical for a majority of individuals in Africa especially those

who live in rural and remote areas. Renewable resources are often the only practical solution for rural electrification. The emerging technologies to provide off-grid power to rural areas, and innovative business models (e.g. mobile money and pay-as-you-go financing) are emerging to promote solar power generation for rural electrification. As the electricity demand is fairly low for rural dwellers, the small-scale PV system is particularly appropriate for households in rural or even urban areas with undependable grid services. The diverse application of solar PV in rural areas includes Solar Home Systems (SHSs), street lighting, water pumping systems, and solar lanterns. A number of countries are investing in solar power generation for rural electrification. Nigeria is targeting to increase the share of solar power generation to 20% of the total electricity generation by 2030. Presently, the generation mix includes 86% of gas-fired plants and 14% of hydropower. The “Jigawa 1 GW Solar Procurement Programme” is a rural solar energy electrification program developed by the Nigerian Rural Electrification Agency to use PV and concentrated solar power technologies for generating electricity in northern Nigeria [10]. Off-grid solar systems are fairly prevalent in East Africa and it is estimated that the capacity of off-grid SHS reaches 1,000 MW by 2022 [11].

In Bangladesh, SHS initiative introduced in January 2003, was supported by the government-owned Infrastructure Development Company Limited (IDCOL) to serve the off-grid rural communities as a part of the government’s effort to warrant electricity access to all residents of Bangladesh by 2021. Approximately 4.12 million SHSs were developed until May 2017, in the areas where the grid expansion was challenging and costly. The program secured the solar electricity supply for 12% of the nation’s population and aims to expand the solar generation capacity to 220 MW through financing 6 million SHS installations by 2021 [12].

The world bank reported that India has the largest population with no access to electricity in 2014. Despite abundant power supplied using coal generation technology, 240 million people had no access to electricity in 2015-2017 either because of lack of electricity grid infrastructure, or the high price of electricity. In February 2017, the cost of solar PV generation was \$0.046/kWh which is dropped to \$0.041/kWh in May 2017 [13]. This cost is 15% lower than the cost of energy provided by coal generation technology. The progressing economy of renewable generation and the falling economy of the coal energy sector has shifted the focus of the India government and investors toward clean energy. India invested about \$42 billion in the renewable energy sector since 2014 and the share of the solar sector in 2017 was over \$10 billion. In the first half of 2018, the generation capacity of solar PV generation was 767.51 MW and by November 2018, 26694 MW solar generation capacity has been approved to be developed. The share of utility-scale and rooftop solar generation from this expanded capacity is 87% and 13% respectively. By 2022, the Ministry of New and Renewable Energy (MNRE) aims to develop 175 GW capacity for renewable energy resources with a 57% share for solar energy [14]. Trains with rooftop solar panels and solar powered water pumps for agriculture applications are examples of successful projects initiated in 2017 [15]. By 2040, it is expected that the renewable resources provide 49 % of total electricity in India and the price of solar energy drops by 66% with the development of more efficient battery storage [16].

1.3. Transmission and Distribution Loss

The average annual loss in transmission and distribution is estimated as 5% of the generated electricity in the United States [17]. In 2017, 226112 Thousand MWh of energy was lost in the transmission and distribution sectors [18]. The transmission and distribution losses have a direct correlation with the demand in the electricity network. In 2017, the residential and commercial customers utilized about 39% (equal to 38 quadrillion British thermal units) of the total generated electricity in the U.S. [19]. To avoid the cost and the loss associated with transmitting electricity over long distances, solar PV generation is used to supply residential and commercial customers. Installing small-scale or utility-scale PV generation facilities will reduce the net demand being served by the transmission and distribution networks. Net demand is the demand minus the local renewable generation. Reducing the net demand not only improves the available capacity of the transmission and distribution networks but also reduces the energy loss. In 2017, the direct-use electricity (electricity that is generated and consumed without transmitting in transmission and distribution network) was 141,114 Thousand MWhs. The generated electricity of PV units partially contributes to the direct-use electricity that is not transmitted through the network and does not contribute to the network loss.

1.4. Cost of Energy

Electricity prices are highly dependent on the volatility of the fossil fuel market and availability of the fuel, especially in the islands such as Hawaii that still heavily rely on imported oil for generating electricity. Hawaii's residents pay approximately 3 times as much for the electricity as the rest of the United States. The average price of electricity in 2014 was \$0.34/kWh in Hawaii compared to \$0.10/kWh in the rest of the U.S. High electricity prices, ample solar resource, and progressive energy policies including tax credits and the utilities' distributed energy resource programs yield unprecedented growth of solar generation in Hawaii. The cumulative solar capacity installed in Hawaiian Electric, Hawaii Electric Light, and Maui Electric is 695 MW at the end of 2017 which shows 109 MW increase from 2016. This increase in capacity includes 82,000 rooftop solar systems that are approved for interconnection as well as the addition of 27.6 MW Waianae solar facility that provides some of the state's cheapest renewable generation. Recently, the public utility commission issued an order to update Hawaii's existing interconnection program, creating two new tariffs for distributed energy resources to provide an option to the customers with rooftop solar generation and home energy storage to reduce their energy bills by exporting the excess power captured during the day to non-daytime hours. Beyond distributed PV generation resources, the utility-scale PV generation contributed to the reduction of energy costs for Hawaii residents [20]. Examples of such projects include Waianae Solar (27 MW) with \$0.145/kWh energy price; 13 MW PV system with 52 MWh battery energy storage with \$0.139/kWh energy price; and a 28 MW PV system with 100 MWh battery energy storage with \$0.11/kWh price of energy. From 2020 all the new households being built in California are required to have solar panels. The solar panels save \$0.168/kWh on average \$0.193 /kWh price of electricity. It is estimated that each installation will save \$9,500 in electricity expenses per building over 30 years [21].

2. Operation Challenges and Solutions in the Distribution Networks

A considerable share of the PV generation is coupled with the low voltage distribution networks. Small-scale PV systems (with the capacity of less than 1 MW) provided about 37% of the annual generation of PV generators in 2016. Such systems are located close to industrial, commercial and residential customers. In 2016, the residential sector in the U.S. had 52% of the total small-scale solar PV generation [22]. The annual U.S. small-scale PV generation capacity is expected to rise from 19,467 gigawatt-hours (GWh) in 2016 to 32,900 GWh in 2018 [23] and the small-scale PV capacity is 40% of the total grid-connected solar capacity in the U.S. California has the largest installed capacity of small-scale PV output in 2016 [24]. The continuous integration of distributed energy resources (DERs) from small-scale rooftop installations with several kilowatts capacity to large scale (tens of MW) generation capacities offers many advantages to the economy and environment; however, maintaining the stability of the distribution system, and ensuring the reliability and power quality of service are among the challenges faced by the distribution network operators. The increase in the installed capacity of photovoltaic (PV) generation introduces technical complications triggered by the mismatch between the generation and demand in the low-voltage distribution networks. The uncertainties in the available solar irradiation and the increase in the real power injection at buses with excess PV generation at hours of peak PV generation and off-peak load may lead to overvoltage in the network. The overvoltage could go beyond the thresholds that could be handled by the inverter protection system. Maintaining the voltage within the acceptable range (0.88 p.u. – 1.1 p.u. according to IEEE1547) is crucial as any violation would lead to disconnection of the distributed generation from the network. The increase in the voltage at buses with excess PV generation leads to the reverse power flow to the main substations while high demand and low PV generation would cause extensive voltage drop along the feeder [25]. Furthermore, voltage fluctuation, flicker, harmonics, unbalanced power flow, and line overloading are among the emerging challenges related to the large-scale integration of PV generation in the distribution networks. In order to alleviate the adverse effects of PV generation, developing effective operation planning solutions is crucial for the utilities with such considerable installed capacities. The State of Hawaii aims to increase the penetration level of renewable energy to 100% by 2045. If not addressed properly, such a high penetration of PV generation would eventually degrade the power quality, and cause reliability issues in the distribution network. In this section, two main operation functions to reduce these adverse effects are addressed: a) voltage control; and b) the optimal operation planning of the distribution networks.

2.1. Voltage Control in Distribution Network

Voltage regulation at the load buses is the vital concern for the utilities with a considerable capacity of PV generation. Conventionally, voltage regulation in the distribution network is performed by tap changers, switched capacitors (SCs), and step voltage regulators (SVRs). Fig. 1 shows a radial distribution network with voltage regulation devices. As shown in this figure, the transformer connected to the utility feeder is equipped with an on-load tap changer (OLTC) to regulate the voltage at bus “A”. To do so, it measures the current at utility substation and estimates the voltage drop along the feeder at bus “D” where the load is being served. Unlike the transformer with OLTC that is usually placed on distribution feeder, the SVR is a tap changing automatic regulator placed along the feeder [26]. In this figure, the SVR regulates the voltage on bus “C”. Consequently, the voltage on the load bus (i.e. bus “D”) can be adjusted. Switched capacitors (SCs) adjust the voltage at connected buses by regulating the reactive power with controlled switching. The transformer with OLTC and SVR regulate the voltages assuming forward flow of power from bus “A” toward the load at bus “D”. These devices compensate for the voltage drop along the line impedance by increasing the voltage in the upstream bus.

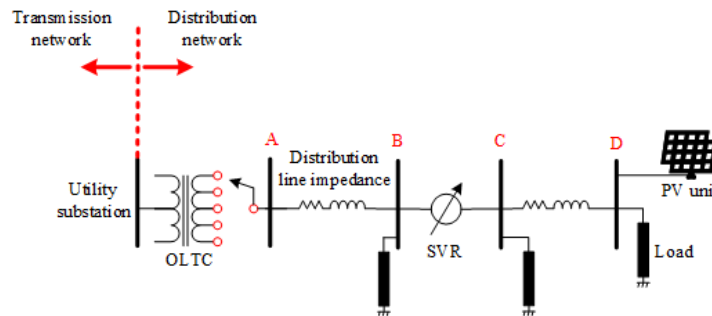

Fig. 1. Distribution network with voltage regulation assets

The voltage regulating devices are controlled independently by considering the local measurements of current and voltage at the installed locations. Integrating PV units at bus “D”, may lead to bidirectional power flow in the distribution feeder. Particularly for large PV units, the potential excess generated power at bus “D” leads to reverse power flow from bus “D” towards bus “A” that finally results in overvoltage at bus “D”. Fig. 2 shows the Thevenin equivalent of the utility grid with a voltage source and series impedance. Typically, the series impedance of the utility is small, thus the voltage drop is not significant. Despite the small magnitude of the series impedance of the utility, the loads’ currents could be sufficiently high to have a significant voltage drop on the series impedance. As a solution, grid operators increase the sending voltage on the utility end to maintain the voltage of the load bus in the acceptable range. Increasing the voltage on the utility end can be problematic when the generation of PV units is more than the required load. Because the excessive generation of PV will reverse the power flow direction toward the utility feeder through the series impedance (red arrow shows the direction of the reverse power flow in Fig. 2), a negative voltage drop would exist on the series utility feeder impedance. Thus, the voltage on the load bus would be the summation of utility voltage and the voltage on the series impedance, and therefore, the voltage magnitude on the load bus could easily go beyond the allowed overvoltage threshold.

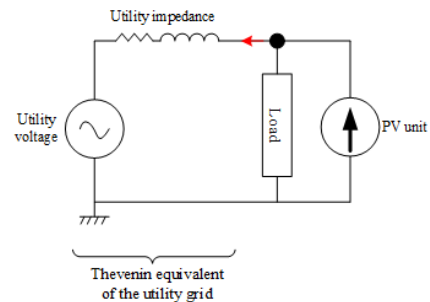

Fig. 2. Utility grid connected to PV generation

Integrating PV units at the load bus not only changes the voltage profile of the feeders by making the power flow bidirectional but also leads to voltage flicker and voltage unbalance at the load ends as the power output of the PV units fluctuates. Voltage unbalance – defined as the ratio of the negative sequence to positive sequence voltage components – is a major problem in the distribution networks. The increase in the voltage unbalance may lead to overheating of motor loads and transformers in the distribution networks. Moreover, inverter-based loads will operate with poor efficiency due to the injection of harmonic currents in case of voltage unbalance in the electricity grid. Unbalanced voltage in the distribution network stems from unequal network impedances, unbalanced three-phase demands across the feeders, and unbalanced PV units’ generation.

Voltage variation and voltage rise have an adverse effect on voltage regulation assets. The OLTC transformer's mechanism is based on the voltage estimation on the load bus by measuring the current at the feeder. Therefore, intermittency of PV units increases the unpredictability of the voltage on load bus and decrease the efficiency of OLTC transformer's performance in voltage regulation. Furthermore, voltage flickers raised by the integration of PV units at the load buses could increase the number of tap changes in the OLTC transformer. OLTC transformer and VRs perform voltage regulations using mechanical tap changers; therefore, they are not fast enough to keep up with the variations of the voltage at the load buses. Moreover, the increased number of operations of these devices results in the increase in the wear and tear and maintenance costs, and reduction in their life cycle. In extreme scenarios, the high reverse power of PV units may damage these devices as they are designed for forward-power flow and usually the permissible reverse power flow is lower than the rated apparent power.

Several control strategies were proposed in the literature to prevent overvoltage through controlling the reactive power [27]. Curtailing the PV generation [28], real and reactive power control [29], utilizing of storage units [30],[31], dynamic voltage restorer (DVR), STATCOM, and SVC in the distribution network, and adjusting the transformer taps are among the practices to prevent overvoltage in the distribution feeders. Regulating real and reactive power can help to mitigate voltage deviations. Controlling the reactive power by the PV inverters could mitigate the overvoltage in the distribution feeder; however, this approach will reduce their effective lifetime [32]. Curtailing PV generation during overvoltage periods is another approach to reduce the voltage in the distribution networks [33]. This technique is more effective compared to controlling the reactive power as the R/X ratio is high in the distribution network. However, the power curtailment strategies adversely affect the PV owners' revenue and reduce the leveraged capacity of PV generation in the network [30].

Most of the recent research on voltage control in distribution system was focused on three-phase radial networks and three-phase PV systems, while limited research effort was dedicated to addressing the challenges in the operation and control of the single-phase PV generation units in the distribution networks. Installing single-phase rooftop PV generation in distribution systems, and the diverse energy usage on each phase will increase the voltage unbalance on the distribution feeder. Considering the high installed capacity of single-phase rooftop PV generation require more efficient approaches to mitigate the voltage unbalance and enhance the power quality in the distribution network. Coordinating PV generation with battery energy storage (BES) is an effective approach to mitigate the voltage unbalance and power flow in the distribution systems. Such coordination further mitigates the fluctuation of net demand, decreases the PV curtailment, improves the stability of the networks to handle the abrupt variations of the demand and mitigates the probability of having reverse power flow in the distribution network. The reduction in the BES costs provide incentives to leverage this technology to a) serve the load in peak periods and reduce the peak electricity demand, b) mitigate PV generation curtailment and smoothen the PV generation profile, and c) compensate for the voltage drops in the distribution feeders.

Centralized, decentralized, and distributed control schemes are the predominant frameworks for voltage control and energy management in the distribution networks. Voltage control in the distribution network can be performed centrally by regulating the injected real and reactive power. This approach requires real-time measurements and strong communication links to ensure the observability of the distribution network. In the decentralized control approach, each entity (e.g. distributed generation (DG) unit) uses local information to autonomously control the voltage at the point of connection. A major advantage of the decentralized control over the centralized control is the independence from the communication network and faster response for voltage control. Furthermore, the autonomous feature of this control methodology increases the controllers' flexibility in dealing with the intermittency of the PV generation units. Another advantage of this control approach is the improvement in the network performance with limited deployment cost of the communication systems. However, this approach increases the power losses in feeders and controllers may interfere with each other's operations. In the distributed control scheme, a sparse network facilitates communication among the local control agents [34]. This scheme is mostly based on a consensus among the agents to reach a global average value by regulating the local system parameters, such as voltage and power generation [34]. The distributed control schemes are superior to centralized control schemes in dependability, expandability and communication costs. In [31], [30]-[35] a consensus-based algorithm is proposed for the voltage control along a balanced radial distribution feeder. The PV reactive voltage control capability for balancing the three-phase unbalanced distribution network is proposed in [36]. In this paper, two types of connections for single-phase PV is considered and the three-phase network

is balanced by using the PVs that are connected among the phases. The centralized control approach in comparison with decentralized and distributed approaches is less complicated to implement. However, it is more expensive as it requires a larger number of communication links between the central controllers and other agents. Distributed control scheme provides a better solution to address the short-comings of centralized and decentralized energy management approaches.

Here, a distributed control approach is proposed to mitigate the unbalanced voltage in the distribution network with high penetration of single-phase PV-BES systems. Single phase PV-BES systems are connected to the distribution feeder and linked together by the communication links. The communication links facilitate reaching a consensus among the PV-BES controllers. Here, a two-level control strategy is proposed in which, in the first level, the voltage along the distribution feeder is regulated and in the second level the three-phase system is balanced by leveraging appropriate control signals in BES systems. The proposed control strategy would manage load/generation balance, regulate voltage for each phase, balance the voltage magnitudes among three-phases and control the state of charge (SOC) of the BES system. The advantages of the proposed control framework are as follows:

- Coordination among single-phase PV and BES systems to balance the unbalanced three-phase distribution network
- Minimizing the PV curtailment based on the capacity of the BES systems

The proposed control framework is shown in Fig. 3. At the first level, the voltage of each phase is measured and if there is a difference between the reference and the measured voltages, an error signal will be sent to the BES converter that is connected to the same phase, to regulate the dispatch. Here, the voltage is locally measured at the grid interconnection point of PV-BES system. The interaction among BES systems using the communication links is shown in Fig. 4. As it is demonstrated, each BES system communicates with its neighbors that are connected to the same phase as well as the BES systems on other phases on the same bus. Coordination among BES systems improve the voltage profile along each phase of the feeder and prevents any violation in the SOC of BES systems. The proposed distributed and coordinated control scheme is based on the weighted consensus strategy, in which the participation factors for increasing/decreasing the voltage are proportional to the capacity of the BES system. During the voltage rise, the power injected by the PV-BES inverter to the grid is reduced by storing the excess PV generation to the battery; and during voltage drop that usually coincidence with low PV generation, the stored energy in BES system is injected back to the grid. The voltage along the feeder can reach a consensus by sharing the measured voltage on each bus along the feeder among the neighboring BES systems. The objective of the proposed distributed control approach for BES systems is to procure the exchanged power among BES systems and the grid to maintain the voltage along the feeder within the acceptable limits. The exchanged power is regulated by controlling the bi-directional inverters and BES buck-boost DC/DC converters. The second level aims to balance the voltage of the unbalanced three-phase system. The communication between the BES systems installed on different phases facilitates the voltage balance on three-phase feeder while the voltage of each phase does not exceed the voltage limits.

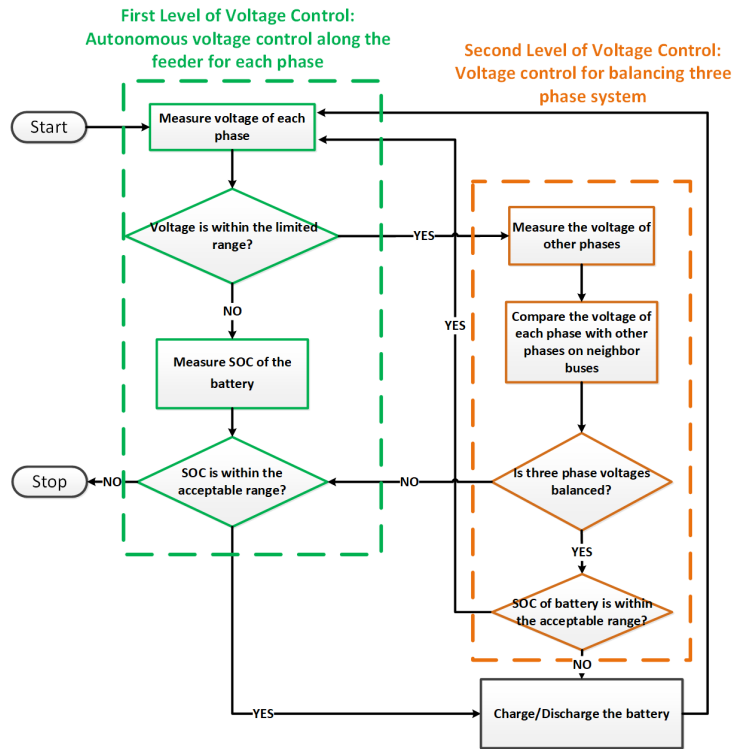

Fig. 3. Two-level control strategy to: a) regulate the phase voltage; b) to balance the three-phase voltage along the distribution feeder

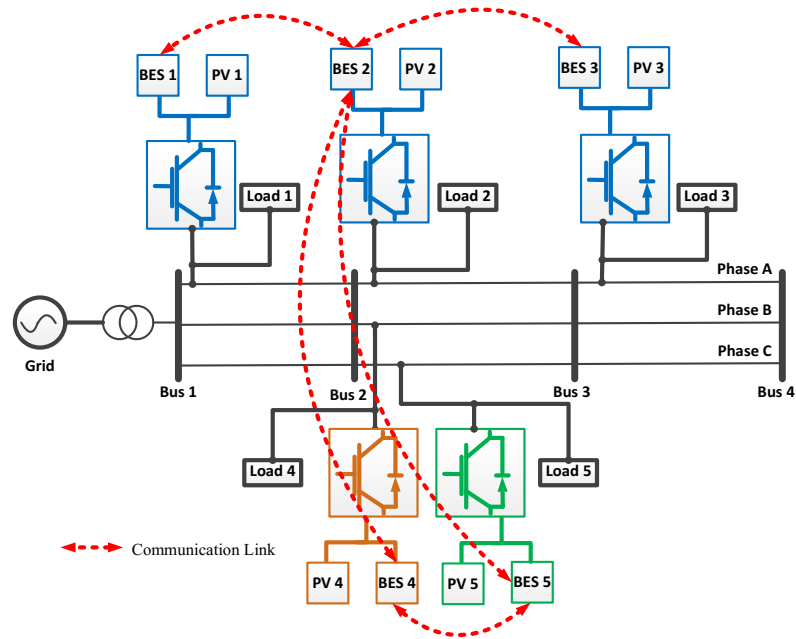

Fig. 4. Network interconnection of BES systems with respective communication links

2.2. Distribution Network Operation Planning

The uncertainty and variability in the PV generation and demand coupled with the possible outages in the network assets, present considerable difficulties to ensure the security and reliability of the distribution networks. The uncertainty and variation in PV generation and demand profiles not only impact the voltage profile in the distribution network but also cause nodal demand and supply mismatches. Currently, utilities rely on PV generation curtailment as a solution to mitigate the mismatch between the generation and demand; however, such solution has an adverse effect on the economic and sustainability of the energy supply and reduces the profit of the entities with PV generation units in the distribution networks. In order to address these challenges, an effective operation planning framework for the distribution networks is required. Such framework is characterized by the following functionalities: 1) Quantify the variability and uncertainty of PV generation and demand to determine an improved estimation of net demand; 2) Develop a quasi-static time series (QSTS) short-term operation planning approach that addresses single or multiple objectives and captures: a) the physical unbalanced AC power flow in the distribution network, b) temporal interdependence among the strategic decisions of autonomous entities including microgrids, DERs, and controllable loads; c) spatial correlation among the operation strategies of autonomous entities; d) system-wide operation strategies including voltage regulation, network reconfiguration, flexible AC transmission system (FACTS) switching, phase balancing, and dispatching the controllable generation and demand resources in the distribution network.

While the operation planning framework is usually focused on minimizing the operation cost, it can also address single or multiple objectives such as improving the voltage profile, minimizing the distribution network loss, or maximizing the reliability of energy supply. The autonomous entities in the distribution network including DERs, controllable loads, and consumers with generation behind the meter that could form microgrid or nanogrids, communicate with the distribution system operator (DSO) to respond to the provided instructions and to ensure the reliability and security of the distribution network. An example of such instructions is to provide real/reactive power support to regulate the voltage along the distribution feeder. The short-term operation planning framework of the distribution network will be formulated as a network/security constrained unbalanced optimal power flow (UOPF) problem. The uncertainties in demand and generation profiles, the contingencies in distribution network (e.g. outages in feeders, DERs, and distribution lines), and the transitions between grid-connected and island modes for microgrids and nanogrids, would impact the power flow and may jeopardize the distribution network security by violating the branch flow and/or bus voltage limits. Considering the uncertainties in the operation horizon as a result of volatile PV generation, demand, and component outages, the DSO leverages risk-based unbalanced optimal power flow tools to procure: 1) the operation strategies for normal condition that address the economics and security of the network, and 2) the corrective operation strategies that eliminate the violations in the network variables triggered by the contingencies and/or variation of generation and demand. Fig. 5 shows the algorithm that addresses the interaction among the DSO and other entities in the distribution network including consumers with behind the meter PV generation and energy storage, such as microgrids and smart buildings [37]. The proposed operation framework supported by the communication network is summarized in the following main steps:

- a) The DSO solves the distribution network operation problem, minimizing the operation cost, voltage deviation or distribution network loss. The problem can capture the unbalanced operation of the distribution network and the imposed uncertainties by PV generation, demand, and availability of the distribution assets;
- b) The decisions made by the DSO are passed as “operation signals” to the local agents including smart buildings with energy storage and PV, microgrid energy management systems, and other autonomous systems with DERs. The agent’s operation sub-problems are solved for their heterogeneous objectives subjected to the local operation constraints including reliability and security constraints, demand behavior and customer preferences. The outcomes of the sub-problems are “response signals” to the DSO reflecting their states and/or other operational requirements. It is worth noting that the mismatch between the “response signal” and “operation signal” is minimized using a penalty factor in the objective function of each distribution network entity.
- c) The DSO will integrate the provided “response signals” and solve the distribution network operation problem to find a new operation solution and update the “operation signals”. In this framework, the mismatches between the “operation signals” and received “response signals” are penalized in the objective function using the

determined penalty factors in the DSO’s network operation problem. This iterative process continues until there would be a consensus among the DSO and other entities in the distribution network. The consensus is reached when the “operation signal” is not updated for each entity and the “operation signal” matches the “response signal”.

The advantage of the proposed approach is that the DSO does not require to consider all operation variables and constraints used by the local entities in distribution network (e.g. room temperatures in smart buildings, reliability requirements of microgrids, network constraints within microgrid territory, etc.). This will increase the solution speed and maintain the privacy of the entities in the distribution network by limiting the shared information among these entities and the DSO.

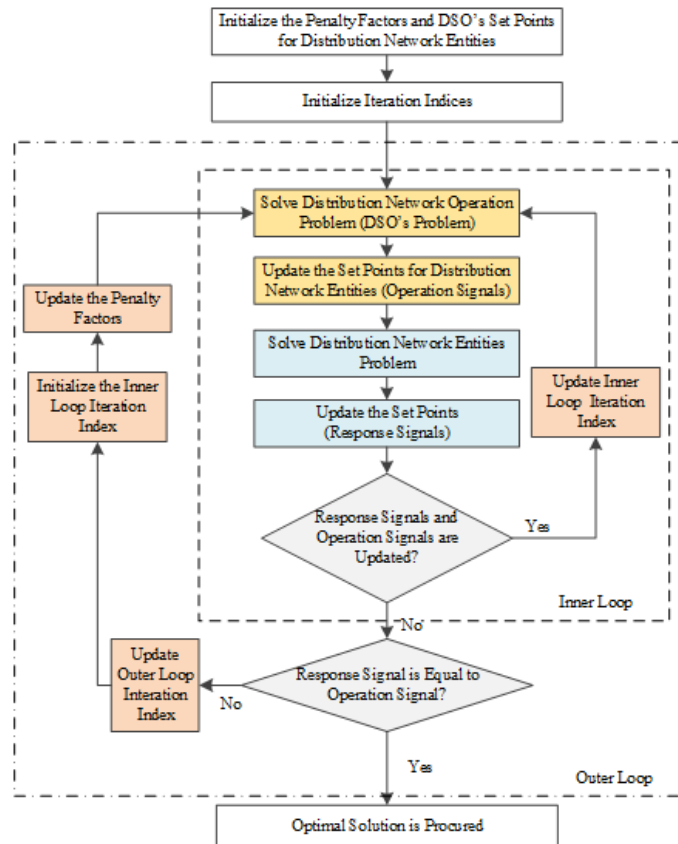

Fig. 5. Distribution Network Operation Framework

3. Conclusion

In this paper, the advantages of PV generation technology to alleviate the challenges in the electricity transmission and distribution network are discussed. The challenges related to emission in electricity generation, rural electrification, cost of energy, and transmission and distribution loss could be addressed with large-scale integration of PV generation close to the residential, commercial and industrial customers. Next, the challenges of operating PV generation in the distribution network is discussed. Specifically, voltage fluctuation, voltage rise, and voltage imbalance are addressed by the proposed voltage control strategy that leverages the communication among energy storage facilities to maintain the voltage along the distribution feeders within the acceptable range. The operation planning of the distribution networks considering multiple generation and demand entities including PV generation, energy storage, smart building, microgrids and other controllable loads is presented. A distributed operation framework is proposed that captures the interactions among the DSO and other entities in the distribution network. The proposed framework features the heterogeneous objectives of distribution network entities and the DSO as well as the privacy and computation efficiency for determining the best operation strategies in the distribution network. The

uncertainty in generation, demand, as well as the availability of the distribution assets, could be captured using the risk-based operation formulations in the proposed framework.

4. References

- [1] “Solar energy,” [Online]. Available: <https://www.ica.org/topics/renewables/solar>
- [2] “U.S. Solar Market Insight,” Dec. 13, 2018. [Online]. Available: <https://www.seia.org/us-solar-market-insight>
- [3] “The Global Carbon Atlas,” Jul. 9, 2018. [Online]. Available: <https://chinapower.csis.org/china-greenhouse-gas-emissions>
- [4] K. Lowder, “China Proposes 75% Increase To 2030 Renewable Energy Target,” Sep. 27, 2018. [Online]. Available: <https://cleantechnica.com/2018/09/27/china-proposes-75-increase-to-2030-renewable-energy-target>
- [5] “Sources of Greenhouse Gas Emissions,” [Online]. Available: <https://www.epa.gov/ghgemissions/sources-greenhouse-gas-emissions>
- [6] “Electricity in the United States is produced with diverse energy sources and technologies”, Apr. 20, 2018. [Online]. Available: https://www.eia.gov/energyexplained/index.php?page=electricity_in_the_united_states
- [7] E. Spiller, P. Sopher, N. Martin, M. Mirzatanun, X. Zhang, “The environmental impacts of green technologies in TX,” *Energy Econ.* vol. 68, pp. 199–214, October 2017.
- [8] “Access to electricity, urban (% of urban population),” [Online]. Available: <https://data.worldbank.org>
- [9] A. Schaltuper, “Two-thirds of Africa’s population still don’t have access to electricity – and it’s threatening the security of the continent,” Jul. 21, 2018. [Online]. Available: <https://www.independent.co.uk/voices/africa-energy-poverty-afdb-kenya-nigeria-lpg-gdp-electricity-europe-global-south-a8449626.html>
- [10] E. Bellini, “Nigeria kicks off 1 GW solar IPP program for rural electrification,” Sep. 7, 2018. [Online]. Available: <https://www.pv-magazine.com/2018/09/07/nigeria-kicks-off-1-gw-solar-ipp-program-for-rural-electrification>
- [11] “Solar leads the charge in another record year for renewables,” Oct. 4, 2017. [Online]. Available: <https://www.ica.org/publications/renewables2017>
- [12] Infrastructure Development Company Limited (IDCOL) [online] <http://idcol.org/home/solar>
- [13] K. Pathi, “From coal to solar, India’s energy landscape is almost too hard to keep up with,” May 2017, [online] <https://qz.com/india/992611/from-coal-to-solar-indias-energy-landscape-is-almost-too-hard-to-keep-up-with/>
- [14] Emerging markets outlook 2018, BloombergNEF, Nov. 2018.
- [15] D. Ghoshal, “India is rolling out trains with solar-powered coaches that’ll save thousands of litres of diesel,” July 2017 [online] <https://qz.com/india/1030696/india-is-rolling-out-trains-with-solar-powered-coaches-thatll-save-thousands-of-litres-of-diesel/>
- [16] Renewable Energy Industry in India, [online] <https://www.ibef.org/industry/renewable-energy.aspx>
- [17] “How much electricity is lost in electricity transmission and distribution in the United States?” Jan. 9, 2019. [Online]. Available: <https://www.eia.gov/tools/faqs/faq.php?id=105&t=3>
- [18] “Electric Power Annual 2017,” Dec. 20, 2018 [Online]. Available: Electric Power Annual 2017
- [19] “How much energy is consumed in U.S. residential and commercial buildings?” May. 3, 2018. [Online]. Available: <https://www.eia.gov/tools/faqs/faq.php?id=86&t=1>
- [20] “Hawaii Energy Facts & Figures,” Energy. Hawaii. Gov. Jun. 2018. [Online]. Available: Hawaii Energy Facts & Figures 2018
- [21] E. Kosak, “Residential PV Costs Within Crashing Distance Of \$1 In California,” Jul. 1, 2018. [Online]. Available: <https://cleantechnica.com/2018/07/01/residential-pv-costs-within-crashing-distance-of-1-in-california>

- [22] "More than half of small-scale photovoltaic generation comes from residential rooftops," Jun. 1, 2017. [Online]. Available: <https://www.eia.gov/todayinenergy/detail.php?id=31452>
- [23] "EIA adds small-scale solar photovoltaic forecasts to its monthly Short-Term Energy Outlook," Jul. 11, 2017. [Online]. Available: <https://www.eia.gov/todayinenergy/detail.php?id=31992>
- [24] "More than half of small-scale photovoltaic generation comes from residential rooftops," Jun. 1, 2017. . [Online]. Available: <https://www.eia.gov/todayinenergy/detail.php?id=31452>
- [25] P. Chaudhary, and M. Rizwan. "Voltage regulation mitigation techniques in distribution system with high PV penetration: A review," *Renewable and Sustainable Energy Reviews* vol. 82, pp. 3279-3287, 2018.
- [26] M. Nasif, A. Zahedi, "Review of control strategies for voltage regulation of the smart distribution network with high penetration of renewable distributed generation," *Renewable and Sustainable Energy Reviews*. vol. 64, pp. 582-595, Jun. 2016.
- [27] Carvalho, Pedro MS, Pedro F. Correia, and Luís AFM Ferreira. "Distributed reactive power generation control for voltage rise mitigation in distribution networks." *IEEE transactions on Power Systems* 23.2 (2008): 766-772.
- [28] Demirok, Erhan, et al. "Clustered PV inverters in LV networks: An overview of impacts and comparison of voltage control strategies." *Electrical Power & Energy Conference (EPEC), 2009 IEEE*. IEEE, 2009.
- [29] Tonkoski, Reinaldo, and Luiz AC Lopes. "Voltage regulation in radial distribution feeders with high penetration of photovoltaic." *Energy 2030 Conference, 2008. ENERGY 2008. IEEE*. IEEE, 2008.
- [30] Wang, Yu, et al. "Coordinated control of distributed energy-storage systems for voltage regulation in distribution networks." *IEEE Transactions on Power Delivery* 31.3 (2016): 1132-1141.
- [31] Zeraati, Mehdi, Mohamad Esmail Hamedani Golshan, and Josep M. Guerrero. "A Consensus-Based Cooperative Control of PEV Battery and PV Active Power Curtailment for Voltage Regulation in Distribution Networks." *IEEE Transactions on Smart Grid* (2017).
- [32] Oshiro, Masato, et al. "Optimal voltage control in distribution systems using PV generators." *International Journal of Electrical Power & Energy Systems* 33.3 (2011): 485-492.
- [33] Kabir, M. N., et al. "Coordinated control of grid-connected photovoltaic reactive power and battery energy storage systems to improve the voltage profile of a residential distribution feeder." *IEEE Transactions on industrial Informatics* 10.2 (2014): 967-977.
- [34] Golsorkhi, Mohammad S., et al. "A distributed control framework for integrated photovoltaic-battery-based islanded microgrids." *IEEE Transactions on Smart Grid* 8.6 (2017): 2837-2848.
- [35] Zeraati, Mehdi, Mohamad Esmail Hamedani Golshan, and Josep M. Guerrero. "Distributed control of battery energy storage systems for voltage regulation in distribution networks with high PV penetration." *IEEE Transactions on Smart Grid* 9.4 (2018): 3582-3593.
- [36] Zeraati, Mehdi, Mohamad Esmail Hamedani Golshan, and Josep M. Guerrero. "Voltage Quality Improvement in Low Voltage Distribution Networks Using Reactive Power Capability of Single-Phase PV Inverters." *IEEE Transactions on Smart Grid* (2018).
- [37] S. D. Manshadi, and M. E. Khodayar. "Decentralized operation framework for hybrid AC/DC microgrid." 2016 North American Power Symposium (NAPS). IEEE, 2016.