

## D meson – pion scattering on CLS 2+1 flavor ensembles

---

**John Bulava,<sup>a</sup> Ben Hörz,<sup>b</sup> Renwick, J. Hudspeth,<sup>c</sup> Christopher Johnson,<sup>c</sup> Daniel Mohler<sup>c,d,\*</sup> and Colin Morningstar<sup>e</sup>**

<sup>a</sup>*Deutsches Elektronen-Synchrotron DESY,  
Platanenallee 6, 15738 Zeuthen, Germany*

<sup>b</sup>*Intel Deutschland GmbH  
Dornacher Strasse 1, 85622 Feldkirchen, Germany*

<sup>c</sup>*GSI Helmholtz Centre for Heavy Ion Research,  
64291 Darmstadt, Germany*

<sup>d</sup>*Institut für Kernphysik, Technische Universität Darmstadt,  
Schlossgartenstrasse 2, D-64289 Darmstadt, Germany*

<sup>e</sup>*Dept. of Physics, Carnegie Mellon University,  
Pittsburgh, Pennsylvania 15213, USA*

*E-mail:* [daniel.mohler@tu-darmstadt.de](mailto:daniel.mohler@tu-darmstadt.de)

We report progress on finite-volume determinations of heavy-light-meson – Goldstone boson scattering phase shifts using the Lüscher method on CLS 2+1 flavor gauge field ensembles. In a first iteration we will focus on D-meson – pion scattering in the elastic region at various pion masses using ensembles with three lattice spacings. We employ ensembles on the CLS trajectory with a fixed trace of the quark-mass matrix as well as ensembles with a strange-quark mass fixed close to its physical value. This will allow us to study both the light- and the strange quark-mass dependence of positive parity heavy-light hadrons close to threshold.

*The 39th International Symposium on Lattice Field Theory (Lattice2022),  
8-13 August, 2022  
Bonn, Germany*

---

\*Speaker

## 1. Introduction

In recent years the determination of scattering amplitudes from Lüscher’s finite volume method [1, 2] has progressed tremendously, see for example [3] for a review. As part of this progress, proof of principle calculations have been performed for many physical systems. While successfully illustrating the possibilities of these methods most determinations of scattering amplitudes have been limited to a single lattice spacing and to just a few values of the light- and strange-quark masses.

In our project we plan to calculate scattering of heavy-light mesons with the QCD (pseudo) Goldstone bosons (pions and kaons) for a variety of light-quark masses and lattice spacings. This will allow for the determination of the scattering lengths as well as the determination of pole singularities related to QCD bound states and resonances like the  $D_{s_0}^*(2317)$  or  $D_0^*(2300)$ . For the latter, unitarized  $\chi PT$  leads to a much lower mass (see [4, 6] and references therein) than indicated by the PDG [5]. This picture has recently been qualitatively confirmed in a calculation by the Hadron Spectrum Collaboration [7], where a pole mass much lower than the naive PDG value has been obtained. Note that this is not in contradiction with old results in [8] (where a Breit-Wigner has been assumed) when a pole search is performed with that data.

Results from such studies can be used as input for effective field-theory fits as recently presented in [6, 9], where the authors obtain the low energy constants in the chiral EFT from fits to heavy-light ground-state masses and elastic phase-shifts from Lattice QCD. This promising approach bridges the gap between lattice data at unphysical pion masses and physical (coupled-channel) systems.

In Section 2 we review the gauge configurations and lattice methodology used for our calculations. A crucial ingredient is the use of a relativistic heavy-quark action. The non-perturbative tuning of this action is detailed in [10] and briefly reviewed in Section 3. We then proceed to illustrate the expected quality of the data for elastic D-meson – pion scattering in Section 4 and conclude with a brief outlook.

## 2. Lattice Methodology

We use the gauge field configurations generated [11, 12] by the CLS consortium with 2+1 flavors of improved Wilson fermions. Figure 1 shows an overview of existing gauge field configurations along two different quark-mass trajectories. The bulk of the CLS ensembles are generated along a trajectory with constant trace of the (light and strange) quark-mass matrix and these ensembles are shown in the left pane of the figure. The right pane of the figure shows ensembles where the strange-quark mass is instead kept constant at approximately the physical strange-quark mass. We use the lattice scale determined in [13] to translate results to physical units.

To calculate observables we use the distillation method [14], particularly in the form of stochastic distillation or stochastic Laplacian Heavyside (LapH) smearing [15]. Table 1 illustrates the stochastic distillation scheme employed in this study. For “fixed” lines connecting the hadron sources and sinks we use a different scheme than for the “relative lines” starting and ending at the same timeslice; while both schemes use interlacing in Laplacian eigenmodes, only the relative lines use time interlacing. Note that this scheme has by now been extensively employed, see for example [16]. This scheme allows us to construct correlator matrices build from both quark-antiquark and

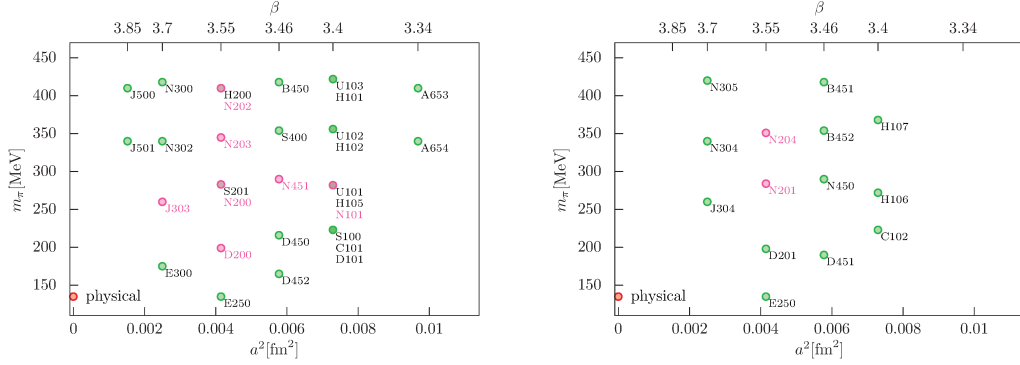

**Figure 1:** Overview of gauge field ensembles generated by the CLS consortium along quark-mass trajectories with constant trace of the quark-mass matrix (left pane) and along a trajectory where the strange-quark mass has been fixed to its physical value (rhs pane). The ensembles highlighted with magenta color will be used in the current project.

quark-line type	dilution scheme	# source times	$N_\eta$	# inversions
charm NXXX	(TF,SF,LI12)	2	4	384 each
light fixed NXXX	(TF,SF,LI12)	2	6	576 each
light relative NXXX	(TI8,SF,LI12)	interlaced	2	768 each
strange fixed NXXX	(TF,SF,LI12)	2	3	288 each
charm D200	(TF,SF,LI16)	3	4	768
charm J303	(TF,SF,LI12)	4	4	768
strange fixed J303	(TF,SF,LI12)	4	3	576

**Table 1:** Stochastic distillation scheme used for the gauge field ensembles in this study.  $N_\eta$  refers to the number of noises for a given quark line. For further description see main text.

meson-meson interpolators (projected to specific momenta) for all quantum numbers of interest. The perambulator matrices encoding the quark-propagation have been saved to disk for future use, while we calculate the Laplacian eigenmodes on the fly for each new run.

### 3. Tuning a relativistic heavy-quark action

In a practical calculation using Lüscher’s finite-volume method [1, 2] we need to reliably determine small energy shifts with regard to the non-interacting finite-volume energies. As typical gauge-field libraries contain only a few volumes for any given combination of the inverse gauge coupling  $\beta$  and the dynamical quark masses, the use of moving frames to obtain different kinematics is crucial. In moving frames discretization effects affecting the dispersion relation are a particular concern, as a substantially altered dispersion relation introduces hard-to-quantify systematic uncertainties for precisely determining small energy shifts, in particular in a coupled-channel scenario. It is therefore highly desirable to minimize in particular heavy-quark discretization effects. This can be achieved with a properly tuned RHQ action, where a detailed discussion of the discretization effects has been provided in what is also known as the Fermilab approach, see in particular [17–19].

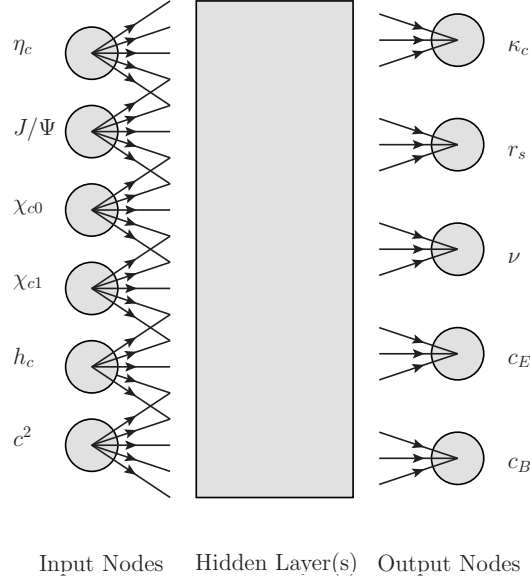

**Figure 2:** Illustration of the neural net used for the non-perturbative tuning of our charm-quark action.

For our project we will use the RHQ action in the concrete form of [20] with 5 parameters, but we would like to emphasize that 3 or 4 parameter versions used previously in the literature [21] could instead be used. We opt to tune the parameters of the heavy-quark action non-perturbatively using a neural net machine-learning approach detailed in a recent publication [10].

For our tuning we calculate some low lying stable charmonium states at zero and non-zero momentum drawing our action parameters randomly from Gaussian distributions. We proceed to determine their masses and the speed of light squared  $c^2$ . We use about 20-50 runs per gauge ensemble and split up this dataset into a training and a validation set. The setup of our neural net is illustrated in Figure 2. Once (partially trained) we use the physical masses and physical speed of light as input for the neural network, which then makes parameter predictions expected to reproduce the stable states and a relativistic dispersion relation. By performing additional runs with parameters close to these predictions we can further improve our training data set. As we observe only a negligible dependence on the light sea-quark masses we also make parameter predictions using several ensembles at a given lattice spacing.

The left pane of Figure 3 shows the measures speed of light squared for our resulting action parameters on all ensembles used in the tuning. As can be seen typical deviations from one are less than 1%. The right pane of the Figure shows the measured dispersion relation for the heavy-light  $D$  and  $D^*$  mesons (data points) compared to the relativistic dispersion relation (green line) on CLS ensemble N451. A quantitative analysis for heavy-light mesons is still work in progress.

#### 4. Towards D-meson – pion scattering

Figure 4 show the extracted energy spectrum in the rest frame and in one of the moving-frame irreducible representations. Expected none-interacting  $D$ -meson – pion energy levels are shown as red solid lines (included in the basis) and red dashed lines (not included). We also show a rough

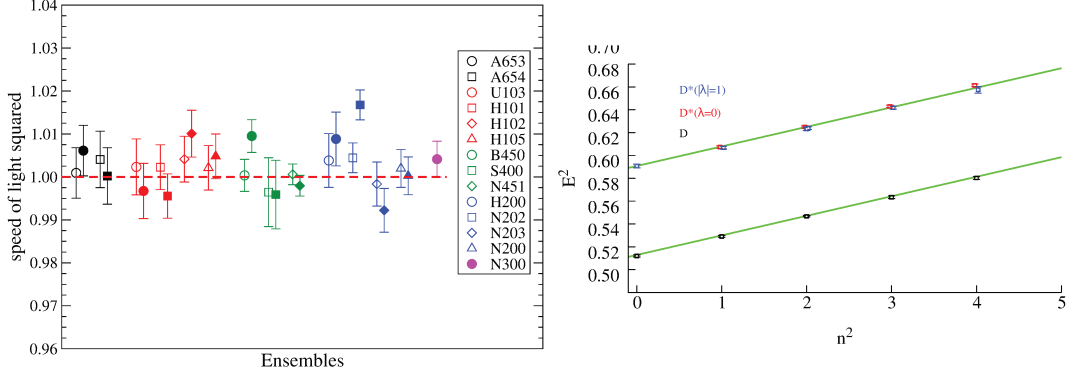

**Figure 3:** Left pane: Spin-averaged speed of light squared for the tuned RHQ action. Open symbols are from tuning parameters on each ensemble singly, while closed symbols are from using all ensembles with a given  $\beta$  and neglecting possible light- and strange-quark mass dependence. Right pane: Dispersion relation for heavy-light  $D$  and  $D^*$  mesons on ensemble N451.

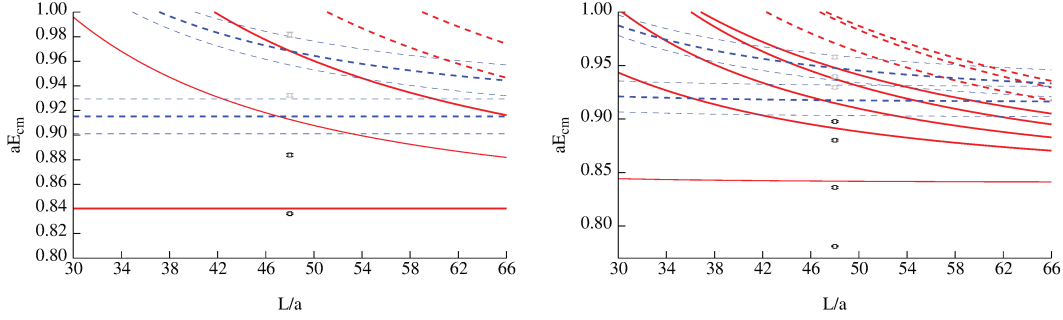

**Figure 4:** Low-lying finite volume energies extracted in the  $A1^+$  rest-frame irrep and in the  $A1$  moving-frame irrep with frame momentum  $(0, 0, 1)$  in units of  $\frac{2\pi}{L}$ . The non-interacting energy levels are given by the red and blue lines described in the text. Grey data points are currently not used in the analysis.

estimate of the  $D$ -meson –  $\eta$  threshold and its uncertainty in blue. The data points displayed in black are currently used in the analysis, while the grey data points are for now excluded. Note that an additional low-lying level due to the  $D^*$  meson is visible in the right pane of the figure. Overall we see a similar pattern than in [7].

Note that the subduction pattern of continuum  $J^P$  states into the lattice irreps has been worked out in [7, 22] and we show the corresponding result in Table 2. As can be seen the mixing pattern is quite complicated for the case of unequal hadron masses.

Figure 5 shows very preliminary result for the S-wave  $D$ -meson – scattering phase-shift close to threshold on CLS ensemble N451 at a pion mass of approximately 280 MeV and with a lattice spacing  $a \approx 0.074$  fm. While this result is from the full set of 1011 gauge-field configurations, only 1 time source has been used so far, and correspondingly a better statistical precision can be expected for future results on this ensemble. In addition to S-wave scattering, we are also planning to investigate scattering in P-wave.

$\vec{P}/\frac{2\pi}{L}$	Irrep	$J^P(\vec{P}=0),  \lambda (\eta)(\vec{P}\neq 0)$	$D\pi J^P$	$D^*\pi J^P$
(0,0,0)	$A1^+$	$0^+, 4^+$	$0^+$	
	$T1^-$	$1^-, 3^-$	$1^-$	
	$E^+$	$2^+, 4^+$	$2^+$	
(0,0,n)	$A1$	$0^{(+)}, 4$	$0^+, 1^-, 2^+$	
	$E2$	$1, 3$	$1^-, 2^+$	$1^+$
(0,n,n)	$A1$	$0^{(+)}, 2, 4$	$0^+, 1^-, 2^+$	
	$B1$	$1, 3$	$1^-, 2^+$	$1^+$
	$B2$	$1, 3$	$1^-, 2^+$	$1^+$
(n,n,n)	$A1$	$0^{(+)}, 3$	$0^+, 1^-, 2^+$	

**Table 2:** Subduction pattern of continuum  $J^P$  states for various momentum rays (see [7, 22]) specified by  $\vec{P}/\frac{2\pi}{L}$  and various irreps.

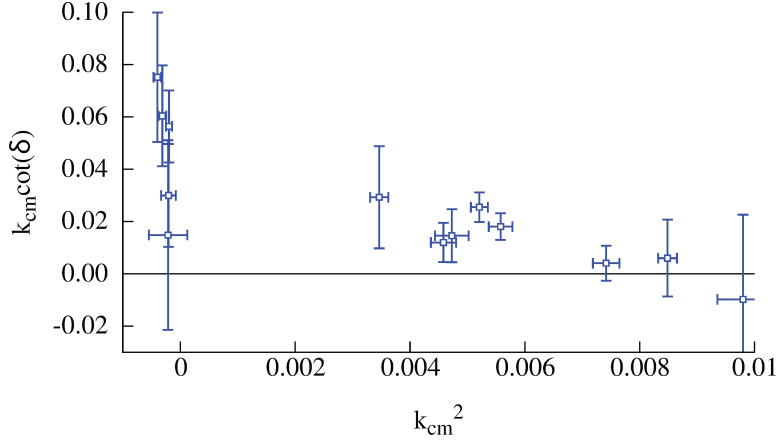

**Figure 5:** Preliminary results for the (elastic) s-wave scattering phase shift  $\delta$  displayed as  $k_{cm} \cot \delta$  over the center-of-mass momentum squared  $k_{cm}^2$  on CLS ensemble N451.

## 5. Summary and outlook

We are studying elastic D-meson – pion scattering with various light- and strange-quark masses and for multiple lattice-spacings using the CLS 2+1 flavor configurations. For the charm valence quark we use a relativistic quark action which was tuned using the low-lying charmonium spectrum. To control discretization effects we will perform our calculation at 3 lattice spacings. Discretization effects of the binding energy are of particular concern, as a recent study of the H-Dibaryon on CLS ensembles at unphysical quark masses [23] shows unexpectedly large discretization effects in the binding energy. The investigation of the light- and strange-quark mass-dependence is a particular focus of our study. In the future we plan to extend our calculations to coupled 2-hadron channels for which additional perambulators will need to be calculated for valence-quark diagrams containing strange-quark annihilation. We also plan to extend our investigation to multiple partial

waves and different flavor quantum numbers. With regard to future amplitude analysis, we plan to work towards an EFT or dispersive analysis to implement (further) constraints (from analyticity, unitarity, and crossing symmetry) for the amplitudes.

## Acknowledgments

D.M. acknowledges funding by the Heisenberg Programme of the Deutsche Forschungsgemeinschaft (DFG, German Research Foundation) – project number 454605793. CJM acknowledges support from the U.S. NSF under award PHY-1913158. Some simulations were performed on the national supercomputer HPE Apollo Hawk at the High Performance Computing Center Stuttgart (HLRS) under the grant number RinQCD4PANDA. This research was supported in part by the cluster computing resource provided by the IT Division at the GSI Helmholtzzentrum für Schwerionenforschung, Darmstadt, Germany (HPC cluster Virgo). We would like to thank the CLS consortium for providing the gauge configurations used in this work.

## References

- [1] M. Lüscher, *Volume Dependence of the Energy Spectrum in Massive Quantum Field Theories. 2. Scattering States*, *Commun. Math. Phys.* **105** (1986) 153–188.
- [2] M. Lüscher, *Two particle states on a torus and their relation to the scattering matrix*, *Nucl. Phys.* **B354** (1991) 531–578.
- [3] R. A. Briceño, J. J. Dudek and R. D. Young, *Scattering processes and resonances from lattice QCD*, *Rev. Mod. Phys.* **90** (2018) 025001, [1706.06223].
- [4] M.-L. Du, F.-K. Guo, C. Hanhart, B. Kubis and U.-G. Meißner, *Where is the lightest charmed scalar meson?*, *Phys. Rev. Lett.* **126** (2021) 192001, [2012.04599].
- [5] PARTICLE DATA GROUP collaboration, R. L. Workman et al., *Review of Particle Physics*, *PTEP* **2022** (2022) 083C01.
- [6] M. F. M. Lutz, X.-Y. Guo, Y. Heo and C. L. Korpa, *Coupled-channel dynamics with chiral long-range forces in the open-charm sector of QCD*, [2209.10601](#).
- [7] HADRON SPECTRUM collaboration, L. Gayer, N. Lang, S. M. Ryan, D. Tims, C. E. Thomas and D. J. Wilson, *Isospin-1/2  $D\pi$  scattering and the lightest  $D_0^*$  resonance from lattice QCD*, *JHEP* **07** (2021) 123, [2102.04973].
- [8] D. Mohler, S. Prelovsek and R. M. Woloshyn,  *$D\pi$  scattering and  $D$  meson resonances from lattice QCD*, *Phys. Rev. D* **87** (2013) 034501, [1208.4059].
- [9] X.-Y. Guo, Y. Heo and M. F. M. Lutz, *On chiral extrapolations of charmed meson masses and coupled-channel reaction dynamics*, *Phys. Rev. D* **98** (2018) 014510, [1801.10122].
- [10] R. J. Hudspith and D. Mohler, *Fully nonperturbative charm-quark tuning using machine learning*, *Phys. Rev. D* **106** (2022) 034508, [2112.01997].

- [11] M. Bruno et al., *Simulation of QCD with  $N_f = 2 + 1$  flavors of non-perturbatively improved Wilson fermions*, *JHEP* **02** (2015) 043, [[1411.3982](#)].
- [12] RQCD collaboration, G. S. Bali, E. E. Scholz, J. Simeth and W. Söldner, *Lattice simulations with  $N_f = 2 + 1$  improved Wilson fermions at a fixed strange quark mass*, *Phys. Rev. D* **94** (2016) 074501, [[1606.09039](#)].
- [13] M. Bruno, T. Korzec and S. Schaefer, *Setting the scale for the CLS 2 + 1 flavor ensembles*, *Phys. Rev. D* **95** (2017) 074504, [[1608.08900](#)].
- [14] HADRON SPECTRUM collaboration, M. Peardon, J. Bulava, J. Foley, C. Morningstar, J. Dudek, R. G. Edwards et al., *A Novel quark-field creation operator construction for hadronic physics in lattice QCD*, *Phys. Rev. D* **80** (2009) 054506, [[0905.2160](#)].
- [15] C. Morningstar, J. Bulava, J. Foley, K. J. Juge, D. Lenkner, M. Peardon et al., *Improved stochastic estimation of quark propagation with Laplacian Heaviside smearing in lattice QCD*, *Phys. Rev. D* **83** (2011) 114505, [[1104.3870](#)].
- [16] C. Andersen, J. Bulava, B. Hörz and C. Morningstar, *The  $I = 1$  pion-pion scattering amplitude and timelike pion form factor from  $N_f = 2 + 1$  lattice QCD*, *Nucl. Phys. B* **939** (2019) 145–173, [[1808.05007](#)].
- [17] A. X. El-Khadra, A. S. Kronfeld and P. B. Mackenzie, *Massive fermions in lattice gauge theory*, *Phys. Rev. D* **55** (1997) 3933–3957, [[hep-lat/9604004](#)].
- [18] M. B. Oktay and A. S. Kronfeld, *New lattice action for heavy quarks*, *Phys. Rev. D* **78** (2008) 014504, [[0803.0523](#)].
- [19] N. H. Christ, M. Li and H.-W. Lin, *Relativistic Heavy Quark Effective Action*, *Phys. Rev. D* **76** (2007) 074505, [[hep-lat/0608006](#)].
- [20] S. Aoki, Y. Kayaba and Y. Kuramashi, *A Perturbative determination of mass dependent  $O(a)$  improvement coefficients in a relativistic heavy quark action*, *Nucl. Phys. B* **697** (2004) 271–301, [[hep-lat/0309161](#)].
- [21] H.-W. Lin and N. Christ, *Non-perturbatively Determined Relativistic Heavy Quark Action*, *Phys. Rev. D* **76** (2007) 074506, [[hep-lat/0608005](#)].
- [22] D. J. Wilson, J. J. Dudek, R. G. Edwards and C. E. Thomas, *Resonances in coupled  $\pi K, \eta K$  scattering from lattice QCD*, *Phys. Rev. D* **91** (2015) 054008, [[1411.2004](#)].
- [23] J. R. Green, A. D. Hanlon, P. M. Junnarkar and H. Wittig, *Weakly bound  $H$  dibaryon from  $SU(3)$ -flavor-symmetric QCD*, *Phys. Rev. Lett.* **127** (2021) 242003, [[2103.01054](#)].