

A deformation of Robert-Wagner foam evaluation and link homology

Mikhail Khovanov and Nitu Kitchloo

ABSTRACT. We consider a deformation of the Robert-Wagner foam evaluation formula, with an eye toward a relation to formal groups. Integrality of the deformed evaluation is established, giving rise to state spaces for planar $GL(N)$ MOY graphs (Murakami-Ohtsuki-Yamada graphs). Skein relations for the deformation are worked out in details in the $GL(2)$ case. These skein relations deform $GL(2)$ foam relations of Beliakova, Hogancamp, Putyra and Wehrli. We establish the Reidemeister move invariance of the resulting chain complexes assigned to link diagrams, giving us a link homology theory.

CONTENTS

1. Introduction
 2. Deformed evaluation for $GL(N)$ foams
 3. Formal groups and generalized divided difference operators
 4. Deformed $GL(2)$ foam evaluation
 5. Reidemeister moves invariance and link homology
- References

1. Introduction

1.1. MOY graphs and quantum invariants for level one representation. Foams are 2-dimensional combinatorial CW-complexes, often with extra decorations, embedded in \mathbb{R}^3 . They naturally appear [Kh2, KRo2, MV1, MSV, QR, RWd] in the study of link homology theories that categorify quantum \mathfrak{sl}_N or \mathfrak{gl}_N link invariants for level one representations when $N \geq 3$.

Reshetikhin-Turaev-Witten invariants [RT, W] of oriented links L in the 3-sphere \mathbb{S}^3 depend on the choice of a simple Lie algebra \mathfrak{g} and an irreducible representation of \mathfrak{g} associated to each component of L . When $\mathfrak{g} = \mathfrak{sl}_N$ and the components are labelled by level one representations of \mathfrak{sl}_N , the Reshetikhin-Turaev-Witten invariant $P(L) \in \mathbb{Z}[q, q^{-1}]$ can be written [MOY] as a linear combinations of terms $P(\Gamma) \in \mathbb{Z}_+[q, q^{-1}]$ over trivalent oriented planar graphs Γ with edges labelled by integers between 1 to N . $P(\Gamma)$ is known as the Murakami-Ohtsuki-Yamada or *MOY invariant* of Γ .

2020 *Mathematics Subject Classification.* Primary 57K18, 14L05, 18N25.

©2024 by the authors

An edge labelled a corresponds to the identity intertwiner of $\Lambda_q^a V$, the latter a quantum group representation which q -deforms the a -th exterior power of the fundamental representation of the Lie algebra \mathfrak{sl}_N . At this point it is convenient to shift from \mathfrak{sl}_N to \mathfrak{gl}_N , and view $\Lambda_q^a V$ as a representation of $U_q(\mathfrak{gl}_N)$ rather than that of \mathfrak{sl}_N . This change will be more essential at the categorified level of homological invariants rather than for uncategorified quantum invariants, taking values in $\mathbb{Z}[q, q^{-1}]$.

Oriented labelled graphs Γ are built out of trivalent vertices that correspond to suitably scaled inclusion and projection of $\Lambda_q^{a+b} V$ into and out of the tensor product $\Lambda_q^a V \otimes \Lambda_q^b V$, see Figure 1.11.

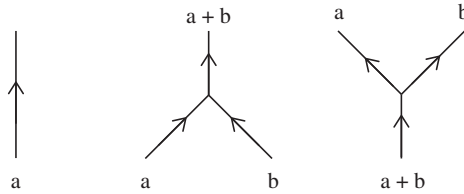

FIGURE 1.11. Generating diagrams for $GL(N)$ MOY graphs. They correspond to the identity intertwiner on $\Lambda_q^a V$ and projection and inclusion (up to scaling) between $\Lambda_q^a V \otimes \Lambda_q^b V$ and $\Lambda_q^{a+b} V$.

Quantum \mathfrak{gl}_N (or MOY) invariant of Γ is given by a suitable convolution of these maps, which for closed graphs Γ results in a Laurent polynomial $P(\Gamma) \in \mathbb{Z}[q, q^{-1}]$ with nonnegative coefficients, see [MOY] for integrality and [RW2, Appendix 2A] for nonnegativity via a suitable state sum formula. Planar graph invariant $P(\Gamma)$ can be computed either via a state sum formula or inductively via skein relations.

As we mention earlier, $\mathbb{Z}[q, q^{-1}]$ -linear combinations of invariants $P(\Gamma)$ give quantum link invariants $P(L)$, when $\mathfrak{g} = \mathfrak{gl}_N$ and components of L are labelled by level one representations, that is, by $\Lambda_q^a V$, over different a 's.

The reason for the popularity of this specialization (from \mathfrak{g} to \mathfrak{gl}_N and to level one representations), especially with an eye towards categorification, is the relative simplicity of these formulas compared to the case of general \mathfrak{g} and its representations, where canonical choices of intertwiners associated to graph's vertices are harder to guess, spaces of these intertwiners may be more than one-dimensional, decomposition of a crossing into a linear combinations of planar graphs has more complicated coefficients or may be difficult to select, and evaluations of $P(\Gamma)$ lose positivity, acquire denominators and live in $\mathbb{Q}(q)$ rather than $\mathbb{Z}_+[q, q^{-1}]$. Any such complication makes categorical lifting noticeably harder. An approach to categorification of the Reshetikhin-Turaev-Witten link invariants for an arbitrary \mathfrak{g} and arbitrary representations has been developed by Webster [We]. It is an open problem to find a foam-like interpretation of Webster link homology theories and refine them to achieve functoriality under link cobordisms.

1.2. Foams and Robert-Wagner evaluation. The key property of $P(\Gamma)$ is it having non-negative coefficients, that is, taking values in $\mathbb{Z}_+[q, q^{-1}]$, rather than just in $\mathbb{Z}[q, q^{-1}]$, where link invariants $P(L)$ live. In the lifting of $P(L)$ to homology groups, state spaces $\langle \Gamma \rangle$ will be graded, with graded rank (as a free

module over the graded ring R_N of symmetric functions, see below) having non-negative coefficients, thus lying in $\mathbb{Z}_+[q, q^{-1}]$, Homology groups $H(L)$ come from complexes of state spaces $\langle \Gamma \rangle$, built from various resolutions Γ of L .

Louis-Hadrien Robert and Emmanuel Wagner discovered a remarkable evaluation formula for $GL(N)$ foams [RW1]. Their formula leads to a natural construction of homology groups (or state spaces) for each planar trivalent MOY graph Γ as above.

At the categorified level of this story, Robert-Wagner foam evaluation leads to a state space $\langle \Gamma \rangle$, a graded module over the ring $R_N = \mathbb{Z}[x_1, \dots, x_N]^{S_N}$ of symmetric polynomials in x_1, \dots, x_N with coefficients in \mathbb{Z} . Robert and Wagner prove [RW1] that the graded R_N -module is free and finitely-generated, of graded rank $P(\Gamma)$.

Thus, graded rank of R_N -module $\langle \Gamma \rangle$ categorifies the quantum \mathfrak{gl}_N invariant (the Murakami-Ohtsuki-Yamada invariant) of these planar graphs. Forming suitable complexes out of these state spaces and taking homology groups leads to bigraded homology theories of links that categorify the HOMFLYPT polynomial and its generalizations to other quantum exterior powers of the fundamental representation [ETW], see also earlier approaches [Y, Wu1, Wu2] to categorification of \mathfrak{gl}_N link homology with components colored by arbitrary level one representations.

We now recall the details of Robert-Wagner’s foam invariant. A $GL(N)$ -foam F is a two-dimensional piecewise-linear compact CW -complex F embedded in \mathbb{R}^3 . Its facets are oriented in a compatible way and labelled by numbers from 0 to N called the *thickness* of a facet (facets of thickness 0 may be removed) with points of three types:

- A regular point on a facet of thickness a .
- A point on a singular edge, which has a neighbourhood homeomorphic to the product of a tripod T and an interval I . The three facets must have thickness $a, b, a + b$ respectively. One can think of thickness a, b facets as merging into the thick facet or vice versa, of the facet of thickness $a + b$ splitting into two thinner facets of thickness a and b .
- A singular vertex where four singular edges meet. The six corners of the foam at the vertex have thickness $a, b, c, a + b, b + c, a + b + c$ respectively.

Neighbourhoods of these three types of points are depicted below.

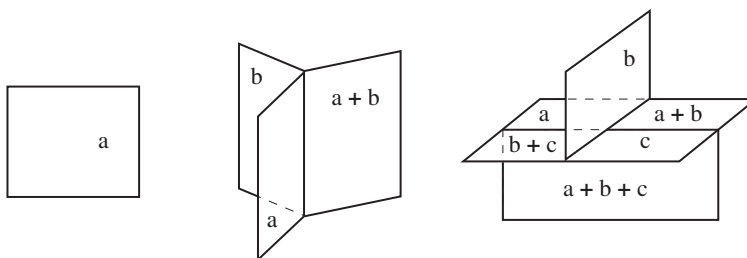

FIGURE 1.21. Three types of points on a foam.

Orientations of facets are compatible at singular edges, see Figure 1.23 below.

A singular vertex can be viewed, see Figure 1.22, as the singular point of the cobordism between two labelled trees that are the two splittings of an edge

of thickness $a + b + c$ into edges of thickness a, b, c , respectively. This is a kind of “associativity” cobordism, which is invertible when viewed as an appropriate module map between state spaces associated to MOY planar graphs in the foam theory. We follow the orientation conventions from [ETW]. They show compatible

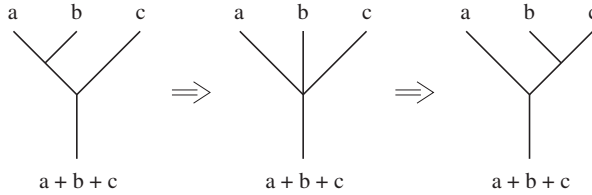

FIGURE 1.22. Cross-sections near a singular vertex.

orientations on facets of thickness a and b attached along a singular edge to a facet of thickness $a + b$. The same diagram shows induced orientations on top and bottom boundaries of foam F . This convention will be used once we pass from closed foams to foams with boundary, viewed as cobordisms between $GL(N)$ MOY graphs.

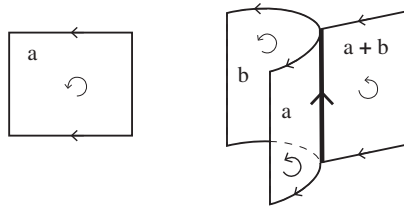

FIGURE 1.23. Orientation conventions from [ETW, Figure 1]. An orientation of a facet induces an orientation of its top boundary (if non-empty, for non-closed foams only) by sticking the first vector of the orientation basis up out of the foam. The remaining vector then induces an orientation of the boundary. For the bottom boundary the resulting orientation is reversed. To induce an orientation on a singular circle, approach it with an orientation basis from a thin facet and point the first vector into the thick facet. The second vector then defines an orientation of the singular circle (or a singular arc, if foam is not closed). This is the one convention we choose out of the four possible conventions for inducing orientations on the boundary and on singular lines, given an orientation of a facet.

Facets f of a foam F are the connected components of the set $F \setminus s(F)$, where $s(F)$ is the set of the singular points of F . Thickness of f is denoted $\ell(f)$. The set of facets of F is denoted $f(F)$. A coloring c of F is a map $c : f(F) \rightarrow 2^{I_N}$ from the set of facets to the set of subsets of $I_N = \{1, \dots, N\}$ such that subset $c(f)$ has cardinality $\ell(f)$ and for any three facets f_1, f_2, f_3 attached to a singular edge with $\ell(f_3) = \ell(f_1) + \ell(f_2)$ equality $c(f_3) = c(f_1) \sqcup c(f_2)$ holds. In other words,

the subset for f_3 is the union of subsets for f_1 and f_2 . A foam may come with decorations (dots). A dot on a facet f of thickness a represents a homogeneous symmetric polynomial P_f in a variables.

Any coloring c gives rise to closed surfaces $F_i(c)$, $1 \leq i \leq N$, which are unions of facets f such that $c(f)$ contains i . One also forms symmetric differences $F_{ij}(c) = F_i(c) \Delta F_j(c)$, which are the unions of facets f such that $c(f)$ contains exactly one element of the set $\{i, j\}$. Surfaces $F_{ij}(c)$, $i \neq j$ are closed orientable as well.

Robert-Wagner evaluation $\langle F, c \rangle_{RW}$ of a foam on a coloring c is

$$(1.1) \quad \langle F, c \rangle_{RW} = (-1)^{s(F,c)} \frac{P(F, c)}{Q(F, c)},$$

where

$$s(F, c) = \theta^+(c) + \sum_{i=1}^N i \chi(F_i(c))/2,$$

$$\theta^+(c) = \sum_{i < j} \theta_{ij}^+(c),$$

$$P(F, c) = \prod_{f \in f(F)} P_f(c),$$

$$Q(F, c) = \prod_{1 \leq i < j \leq N} (x_i - x_j)^{\chi(F_{ij}(c))/2}.$$

Here $\theta_{ij}^+(c)$ counts the number of circular seams on the surface $F_{ij}(c)$ along which the cyclic order of the three attached facets (with i but not j in the coloring c , with j but not i in the coloring, and with i, j in the coloring) is one of the two types, called *positive* type. Positivity is determined by the left hand rule with the direction of the thumb along the positive orientation, on turning the fingers of the left hand from the facet with color i to the one with color j for $i < j$.

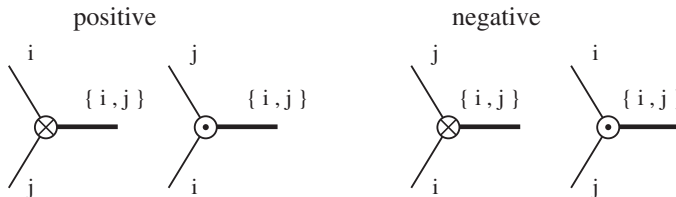

FIGURE 1.24. θ_{ij}^+ counts the number of positive (i, j) -circles, $i < j$.

$\chi(S)$ denotes the Euler characteristic of the surface S . Term $P_f(c)$ is the product of symmetric functions associated to the dots on the facet f , in variables x_k , where k runs over the elements of $c(f)$.

Now define

$$(1.2) \quad \langle F \rangle_{RW} = \sum_c \langle F, c \rangle_{RW},$$

the sum over all colorings c of F . We refer the readers to [RW1] for more details on $GL(N)$ -foams and their evaluations.

Later in the paper we deform Robert-Wagner evaluation and for the most part work with the deformation. To keep notations light, we use Robert-Wagner's notation $\langle F \rangle$ to denote deformed evaluation and denote their original one by $\langle F \rangle_{RW}$.

One of the first key results of Robert and Wagner **[RW1]** is that $\langle F \rangle_{RW}$ is a (symmetric) polynomial rather than just a rational function of x_1, \dots, x_N , thus an element of R_N .

Generic intersection of a foam F with a plane \mathbb{R}^2 in \mathbb{R}^3 will result in an oriented planar graph Γ , which is exactly a $GL(N)$ MOY graph. It is straightforward to introduce foams with boundary. With the evaluation $\langle F \rangle_{RW}$ for closed foams at hand, one can now define the state space $\langle \Gamma \rangle_{RW}$ of Γ as a graded R_N -module freely generated by symbols $\langle F \rangle_{RW}$ of foams F from the empty graph to Γ , modulo the relations that $\sum_k a_k \langle F_k \rangle_{RW} = 0$ for foams F_k from \emptyset to Γ and $a_k \in R_N$ iff for any foam G from Γ to the empty graph $\sum_k a_k \langle GF_k \rangle_{RW} = 0$. Here GF_k is a closed foam, the gluing or composition of G and F_k along Γ . Robert-Wagner state spaces (or homology) of graphs Γ are then used as building blocks for link homology groups **[ETW]**.

As an informal remark, we want to point out that the foams considered in the Robert-Wagner construction **[RW1]** should really be called $GL(N)$ -foams. For $SL(N)$ -foams one would want to allow seamed edges along which three facets of thickness a, b, c with $a + b + c = N$ or $a + b + c = 2N$ meet and allow singular vertices along which such seam edges interact. Robert and Wagner **[RW1, Section 2.3]** briefly discuss how to extend their evaluation to such foams.

Fundamental applications of Robert-Wagner foam evaluation are developed in **[ETW, RW2, RW3]**, with more clearly on the way, see also **[KR, Bo]**. Foam evaluation in the limit $N \rightarrow \infty$ and restricted to foams in special position provides a connection between foams and Soergel and singular Soergel bimodules **[RW2, KRW]**. Other approaches to Soergel and singular Soergel bimodules via foams **[Vz, MV1, QR, RWd, Wd]** do not use foam evaluation, utilizing instead matrix factorizations, more direct foam computations in $N = 2, 3$ cases, and other methods. Earlier, an extension of the Kapustin-Li formula was proposed for foam evaluation **[KR02]**, but due to its more implicit nature was not easy to apply **[MSV]**.

Looking beyond foam evaluation, both foams as they are used in link homology and spin foams **[Ba]** have “foam” in their names, but we don't know if there is a relation between the two theories beyond this observation. Also see Natanzon **[Nt]** and the follow-up papers for yet another direction in the foam theory.

1.3. Formal groups as a motivation. In this paper we propose a deformation of the Robert-Wagner evaluation formula, motivated by algebraic topology and generalized cohomology theories related to formal groups. Link homology theories in the $SL(2)$ case have been lifted to spectra by Lipshitz and Sarkar **[LS1, LS2]** and Hu, Kriz and Kriz **[HKK]**. More recently, a lifting of bigraded $GL(N)$ link homologies as well as the triply-graded homology to equivariant spectra has been constructed by the second author **[K1, K2]**.

Application of generalized cohomology theories to these spectra results in new homological link invariants as well as cohomological operations on them. A purely combinatorial or algebraic description of these homological invariants is clearly desirable, and modifying foam theory and foam evaluation may be a natural first step in this direction.

$GL(N)$ foams are closely related to Grassmannians and partial and full complex flag varieties. A family of cohomology theories known as complex oriented cohomology theories is related to these varieties as well, and to deformations of the formula for the first Chern class in singular cohomology of the tensor product of line bundles $c_1(L_1 \otimes L_2) = c_1(L_1) + c_1(L_2)$ to formulas

$$c_1(L_1 \otimes L_2) = \mathcal{F}(c_1(L_1), c_1(L_2))$$

that hold for the first Chern class invariant in these generalized cohomology theories, where

$$\mathcal{F}(x, y) = x + y + \sum_{i+j>1} a_{i,j} x^i y^j$$

is, in general, a power series in x, y with coefficients in the ground ring. Such a power series admits rich internal structure, making it a *Formal group law*. In Section 3 we shall study formal group laws in detail, but let us briefly point out some relevant structure in this introduction. Among the relations satisfied by $\mathcal{F}(x, y)$ is the associativity relation, which leads to polynomial relations on $a_{i,j}$ which admit a universal solution with one generator for each $k = i + j - 1, k \geq 1$. This solution is hard to write down explicitly, and most manipulations with general formal group laws are implicit [Ha, St] (see section 3 for examples).

With formal group law $\mathcal{F}(x, y)$ at hand, one defines $-_{\mathcal{F}}x$ or $[-1]x$ as the power series $-x + \dots$ which solves the equation $\mathcal{F}(x, [-1]x) = 0$, and forms the power series $x -_{\mathcal{F}}y = \mathcal{F}(x, -_{\mathcal{F}}y)$, also denoted $x[-1]y$:

$$x[-1]y = x -_{\mathcal{F}}y := \mathcal{F}(x, -_{\mathcal{F}}y).$$

This expression deforms $x - y$, so that $x -_{\mathcal{F}}y = x - y +$ higher order terms. One can show $x -_{\mathcal{F}}y = (x - y)q(x, y)$ for an invertible element $q(x, y)$ of a suitable power series ring. We write $x - y = p(x, y)(x -_{\mathcal{F}}y)$ where $p(x, y)q(x, y) = 1$, and use $p(x, y) = q(x, y)^{-1}$ in our computations.

From the standpoint of algebraic topology, $x -_{\mathcal{F}}y$ represents the Euler class (in the cohomology theory corresponding to the formal group law $\mathcal{F}(x, y)$) of the line bundle $\mathcal{L}_1 \otimes \mathcal{L}_2^*$, where \mathcal{L}_1 and \mathcal{L}_2 represent the tautological line bundles over the product space $\mathbb{C}P^\infty \times \mathbb{C}P^\infty$. In other words, the expression $q(x, y)$ should be interpreted as the *relative Euler class* for the bundle $\mathcal{L}_1 \otimes \mathcal{L}_2^*$, in the sense that one compares the Euler classes in the cohomology theory corresponding to $\mathcal{F}(x, y)$, to the standard Euler class in singular cohomology. In this context, products of the form $q(x_{i_1}, x_{j_1})q(x_{i_2}, x_{j_2}) \dots q(x_{i_k}, x_{j_k})$ (which we will come across often in this paper) may be interpreted as the relative Euler class of the *direct sum* of the line bundles corresponding to each factor.

Robert-Wagner foam evaluation formulas contain powers of $x_i - x_j$ in the denominator, and a natural idea would be to carefully replace them with $x_i -_{\mathcal{F}}x_j$. We pursue a variant of this idea in this paper. Similar replacements have already been considered for various formulas in the theory of symmetric functions, including the Weyl formula for the Schur function, see [NN1, NN2, Na] and references therein. Foam evaluation specializes to the Weyl formula for the Schur function in the case of the so-called theta-foam and its natural generalizations.

On the algebraic topology side, the expressions $x_i - x_j$ for $1 \leq i \neq j \leq N$ have a natural meaning as the Euler classes in singular cohomology for the roots α of $GL(N)$ (we have included both positive and negative roots). In particular,

the deformation $x_i - \mathcal{F} x_j$ can be interpreted as the Euler class of α in an exotic cohomology theory corresponding to the formal group law $\mathcal{F}(x, y)$. We may therefore speculate that the corresponding deformed foam evaluation formula is obtained by applying an exotic cohomology theory to a (hitherto undefined) homotopy type. The existence of such a homotopy type for foam evaluations is very compelling given the results by the second author [K1, K2]. Since $GL(N)$ has $N(N - 1)$ roots α representing the weights $x_i - x_j$ in the standard basis for $1 \leq i \neq j \leq N$, we see that our deformed evaluation formulas will be expressible in terms of $N(N - 1)$ parameters given by the relative Euler classes $q(x_i, x_j)$. However, these extra parameters will satisfy certain constraints with coefficients in the algebra of symmetric power series in N -variables (which is the $GL(N)$ -equivariant cohomology of a point). This suggests that the possible underlying homotopy type for foam evaluations is built from universal bundles using suitable subsets of roots of $GL(N)$.

The discussion above motivates our deformation using the language of formal group laws and related cohomology theories. We go into this further in section 3. Interestingly however, although motivated by it, our deformation setup will end up not requiring all the constraints on the power series $q(x, y)$ imposed by a formal group law. For instance, we will not require associativity from our analogue of the power series $\mathcal{F}(x, y)$. We therefore take as Ansatz, the series $p(x, y)$, the inverse of $q(x, y)$, with arbitrary coefficients. Most of the information in the coefficients of $q(x, y)$ will turn out to be redundant in our framework, at least in the $GL(2)$ case. However, it is conceivable that one may endow our constructions with the action of cohomology operations which are sensitive to more coefficients in the power series $q(x, y)$.

1.4. Plan of the paper. In section 2, motivated by analogies with formal group laws, we write down a multi-parameter deformation of the Robert-Wagner evaluation of closed $GL(N)$ -foams and prove its integrality for any such foam. In section 3 we review formal group laws and corresponding generalizations of the divided difference operators. In section 4 we specialize to $N = 2$ and study this deformation, which ultimately adds two more variables, of the $GL(2)$ foam evaluation. Skein relations for the deformed $GL(2)$ foam evaluation are derived in section 4.4. In section 4.5 we work out the ground ring R for the deformed theory, which has four generators E_1, E_2, ρ_0, ρ_1 of degrees 2, 4, $-2, 0$, respectively. For comparison, the ground ring for the usual $GL(2)$ -equivariant link homology has generators E_1, E_2 (also denoted h, t , up to a minus sign). In section 4.6 we show, unsurprisingly, that the state spaces (or homology) of planar $GL(2)$ webs are free modules over the graded ring R of rank $(q + q^{-1})^k$ over the ground ring R , where k is the number of thin circles in a web. In section 5 we extend the state spaces to homology groups of planar link diagrams and show the invariance under the Reidemeister moves.

Specializing power series $p(x, y)$ to $p(x, y) = 1$ recovers the $GL(2)$ foam theory of Beliakova, Hogancamp, Putyra, and Wehrli [BHPW]. Simplifying computations in our section 4 to this case gives a foam evaluation approach to their theory.

$GL(2)$ foam theory that comes from this deformation seems very similar to the $SL(2)$ theory as set up by Vogel [V] and extended by him to get a strong invariant of tangle cobordisms, without the sign indeterminacy. The relation is given by dropping double facets but remembering singular circles along which the

facets attach to the thin surface of a $GL(2)$ foam. $GL(2)$ foam theory also has an overlap with Ehrig-Stroppel-Tubbenhauer’s generic $GL(2)$ foams [EST1].

We have already mentioned connections to Clark-Morrison-Walker [CMW] and Caprau [Ca1, Ca2] who have achieved full functoriality of the $SL(2)$ link homology via diagrammatical calculi that employ singular circles on thin surfaces. These circles should be remnants of attached double facets. Caprau’s theory is $GL(2)$ equivariant, with variables h and a in place of our E_1 and E_2 .

Twisting of $SL(2)$ theories in Vogel [V] is related to the deformation via power series $p(x, y)$ in this paper. We plan to elucidate connections to Vogel [V], Ehrig-Stroppel-Tubbenhauer [EST1], and to Turaev-Turner’s rank two Frobenius algebra structures [TT] in a follow-up paper and also see whether the $p(x, y)$ deformation corresponds to the twisting [Kh4, V] in the $N = 2$ and the general case.

2. Deformed evaluation for $GL(N)$ foams

The $GL(N)$ Robert-Wagner formula has denominators of the form $(x_i - x_j)^{\chi_{ij}(c)/2}$, where $\chi_{ij}(c) = \chi(F_{ij}(c))$ is the Euler characteristic of the bicolored surface $F_{ij}(c)$. The expression $x_i - x_j$ can be generalized to $x_i - \mathcal{F} x_j = x_i[-1]x_j$, where F is a formal group law. Unlike the additive case, when $x - y = -(y - x)$, most formal group laws do not satisfy $x[-1]y = -(y[-1]x)$, while those that do are called *symmetric*. Converting $(x_i - x_j)^{\chi_{ij}(c)/2}$ to $(x_i[-1]x_j)^{\chi_{ij}(c)/2}$ to modify the Robert-Wagner formula may be possible, but it would not contain the opposite terms $x_j[-1]x_i$, that perhaps should be present to maintain some symmetry, despite us having fixed a set of positive roots $\{x_i - x_j\}_{i < j}$.

To distribute the exponent $\chi_{ij}(c)/2$ across both terms $x_i - \mathcal{F} x_j$ and $x_j - \mathcal{F} x_i$, we recall the relation [RW1, Lemma 2.7] on Euler characteristics

$$(2.1) \quad \chi(F_{ij}(c)) = \chi(F_i(c)) + \chi(F_j(c)) - 2\chi(F_{i \cap j}(c)),$$

where $F_{i \cap j}(c)$ is the surface, possibly with boundary, consisting of the union of facets that contain colors i and j ,

$$F_{i \cap j}(c) = F_i(c) \cap F_j(c).$$

The Euler characteristic $\chi(F_{i \cap j}(c))$ may be odd, due to the presence of boundary, but $2\chi(F_{i \cap j}(c))$ is even, as are the other three terms in the formula (since the other three are Euler characteristics of closed surfaces).

Formula (2.1) simply describes the Euler characteristic of the symmetric difference of two spaces, specialized to the case of surfaces $F_i(c)$ and $F_j(c)$ inside a foam. Using shorthand notations, we can rewrite it as

$$(2.2) \quad \chi_{ij}(c) = \chi_i(c) + \chi_j(c) - 2\chi_{i \cap j}(c),$$

where $\chi_i(c) = \chi(F_i(c))$ and $\chi_{i \cap j}(c) = \chi(F_{i \cap j}(c))$. We can now modify the evaluation formula by changing the (i, j) color pair contribution to the denominator to

$$(x_i[-1]x_j)^{\chi_i(c)/2}(x_j[-1]x_i)^{\chi_j(c)/2}$$

and multiplying the numerator by $(x_i - x_j)^{\chi_{i \cap j}(c)}$, to define

$$(2.3) \quad \langle F, c \rangle = (-1)^{\theta^+(c)} \prod_{f \in f(F)} P_f(c) \prod_{i < j} \frac{(x_i - x_j)^{\chi_{i \cap j}(c)}}{(x_i[-1]x_j)^{\chi_i(c)/2}(x_j[-1]x_i)^{\chi_j(c)/2}}$$

We denote the modified evaluation by $\langle F, c \rangle$ and the original one in [RW1] by $\langle F, c \rangle_{RW}$.

Setting aside formal group laws at this point, let us now formally *define* $x[-1]y$ as follows. Choose a commutative graded ring \mathbf{k} and homogeneous elements $\beta_{k,\ell} \in \mathbf{k}$ in degree $-2(k + \ell)$ for all $k, \ell \in \mathbb{Z}_+ = \{0, 1, 2, \dots\}$ such that $(k, \ell) \neq (0, 0)$. The element

$$(2.4) \quad p(x, y) = 1 + \sum_{(k,\ell) \neq (0,0)} \beta_{k,\ell} x^k y^\ell$$

belongs to the power sum ring $\mathbf{k}[[x, y]]$. In general, $\beta_{k,\ell} \neq \beta_{\ell,k}$. The element $p(x, y)$ has the inverse $q(x, y) = p^{-1}(x, y) \in \mathbf{k}[[x, y]]$. Define

$$(2.5) \quad x[-1]y = q(x, y)(x - y) = p(x, y)^{-1}(x - y) \in \mathbf{k}[[x, y]].$$

Equivalently, $x - y = p(x, y)(x[-1]y)$. Denote $p_{i,j} = p(x_i, x_j)$ or, interchangeably, p_{ij} , and $q_{ij} = q(x_i, x_j) = p_{ij}^{-1}$. Then

$$(2.6) \quad x_i[-1]x_j = (x_i - x_j)p_{ij}^{-1}.$$

Note that $x[-1]y = -(y[-1]x)$ iff $p(x, y) = p(y, x)$ iff $\beta_{\ell,k} = \beta_{k,\ell}$ for all k, ℓ . We refer to this as the *symmetric case*.

The universal case is that of the ring

$$(2.7) \quad \mathbf{k} = \mathbb{Z}[\beta_{k,\ell}]$$

over all k, ℓ as above ($k, \ell \in \mathbb{Z}_+, (k, \ell) \neq (0, 0)$). This ring is non-positively graded, with nontrivial homogeneous components in even non-positive degrees $0, -2, -4, \dots$. It is a graded polynomial ring with $k + 1$ generators in degree $-2k$ over all $k \geq 1$. The universal symmetric case is when $\beta_{\ell,k} = \beta_{k,\ell}$ are formal variables over all $0 \leq k \leq \ell, (k, \ell) \neq (0, 0)$.

Convert denominators in (2.3) via (2.6) and combine with a power of $x_i - x_j$ in the numerator to get

$$\frac{(x_i - x_j)^{\chi_{i \cap j}(c)}}{(x_i[-1]x_j)^{\chi_i(c)/2} (x_j[-1]x_i)^{\chi_j(c)/2}} = \frac{(x_i - x_j)^{\chi_{i \cap j}(c)}}{(x_i - x_j)^{\chi_i(c)/2} q_{ij}^{\chi_i(c)/2} (x_j - x_i)^{\chi_j(c)/2} q_{ji}^{\chi_j(c)/2}} = \frac{(-1)^{\chi_j(c)/2} p_{ij}^{\chi_i(c)/2} p_{ji}^{\chi_j(c)/2}}{(x_i - x_j)^{\chi_{ij}(c)/2}}$$

Taking the product over all $1 \leq i < j \leq N$, the minus signs will combine to $(-1)^{\sum_{j=1}^N (j-1)\chi_j(c)/2}$ and

$$(2.8) \quad \langle F, c \rangle = (-1)^{s'(F,c)} \prod_{f \in f(F)} P_f(c) \prod_{i < j} \frac{p_{ij}^{\chi_i(c)/2} p_{ji}^{\chi_j(c)/2}}{(x_i - x_j)^{\chi_{ij}(c)/2}},$$

where

$$(2.9) \quad s'(F, c) = \theta^+(c) + \sum_{j=1}^N (j - 1)\chi_j(c)/2.$$

We can then define, as before,

$$(2.10) \quad \langle F \rangle = \sum_c \langle F, c \rangle.$$

In the Robert-Wagner formula, due to $\chi_i(c) = \chi(F_i(c))$ being even, one can rewrite the sign as

$$(2.11) \quad (-1)^{s(F,c)} = (-1)^{\theta^+(c) + (\sum_{i=1, i \text{ odd}}^N \chi_i(c))/2}$$

versus

$$(2.12) \quad (-1)^{s'(F,c)} = (-1)^{\theta^+(c) + (\sum_{i=1, i \text{ even}}^N \chi_i(c))/2}$$

in (2.9). These two signs differ by $(-1)^{(\sum_{i=1}^N \chi_i(c))/2}$.

Notice that the sum $\sum_{i=1}^N \chi_i(c)$ does not depend on the coloring c of F and can be computed as a sort of Euler characteristic of F , denoted $\chi(F)$. An open facet f of thickness a contributes $a\chi(f)$, an edge where facets of thickness $a, b, a + b$ meet contributes $-(a + b)$, a vertex along which facets of thickness a, b, c merge in two ways into a facet of thickness $a + b + c$ contributes $a + b + c$. In each case, a generalized 0-, 1- or 2-cell of a foam contributes its Euler characteristic times its thickness, defined as the number of surfaces $F_i(c)$, over all i , that contain that generalized cell. Consequently, the sign difference in the two evaluations is by $(-1)^{\chi(F)/2}$, with

$$(2.13) \quad \chi(F) = \sum_{i=1}^N \chi(F_i(c)), \text{ for any coloring } c.$$

Thus, to recover the Robert-Wagner evaluation $\langle F \rangle_{RW}$ from (2.8) and (2.10) one should specialize $p(x, y) = 1$, so that $p_{ij} = 1$ for all $i \neq j$ and scale by the sign,

$$(2.14) \quad \langle F \rangle_{RW} = (-1)^{\chi(F)/2} \langle F \rangle|_{p(x,y)=1}$$

We keep the sign term $(-1)^{\chi(F)/2}$ so that, in the $N = 2$ case, the 2-sphere of thickness one carrying a single dot would evaluate to 1 (upon specializing to $p_{ij} = 1$), as in [BHPW], rather than -1 , as in [RW1]. Adding this sign term is a matter of preference, while we hope that the deformation via $p(x, y)$ will eventually prove significant.

Let us now show that the formula (2.10) given by summing the expressions (2.8) over all colorings gives rise to a symmetric power series that does not involve denominators. We begin with a simple lemma:

LEMMA 2.1. *Given a coloring c , let $p(c)$ denote the expression*

$$p(c) = \prod_{1 \leq i < j \leq N} p_{ij}^{\chi_i(c)/2} p_{ji}^{\chi_j(c)/2}.$$

Let c' be a coloring obtained from c by a Kempe move relative to 1 and 2 along a connected surface Σ_s , then one has a relation

$$p(c') = p(c) p_{1,2,s},$$

where $p_{1,2,s}$ is the expression

$$p_{1,2,s} := \frac{p_{12}^{\chi(F_2 \cap \Sigma_s)/2 - \chi(F_1 \cap \Sigma_s)/2}}{p_{21}^{\chi(F_2 \cap \Sigma_s)/2 - \chi(F_1 \cap \Sigma_s)/2}} \prod_{2 < j \leq N} \frac{p_{1j}^{\chi(F_2 \cap \Sigma_s)/2 - \chi(F_1 \cap \Sigma_s)/2}}{p_{2j}^{\chi(F_2 \cap \Sigma_s)/2 - \chi(F_1 \cap \Sigma_s)/2}}.$$

Notice, in particular, that $p_{1,2,s}$ is an invertible power series starting with 1, and the transposition σ that switches the variables x_1 and x_2 has the property

$$\sigma(p_{1,2,s}) = \frac{1}{p_{1,2,s}}.$$

Furthermore, $p_{1,2,s}$ is of the form $p_{1,2,s} = 1 \pmod{(x_1 - x_2)}$.

PROOF. The relation between $p(c')$ and $p(c)$ is straightforward to verify, and is left to the reader. Now, since $p_{1,2,s}$ is an invertible power series, we may consider the expression

$$p_{1,2,s} - \frac{1}{p_{1,2,s}} = \frac{1}{p_{1,2,s}}((p_{1,2,s})^2 - 1).$$

The above expression switches sign under the action of the transposition σ , and is therefore divisible by $(x_1 - x_2)$. We conclude that $(x_1 - x_2)$ divides the expression $(p_{1,2,s})^2 - 1$. Factoring this expression, we see that $(x_1 - x_2)$ must divide $p_{1,2,s} - 1$. \square

REMARK 2.2. Notice that the definition of $p_{1,2,s}$ as a ratio of $p(c')$ and $p(c)$ can be extended to the case when c' is a coloring obtained from c by a $(1, 2)$ -Kempe move along several connected components

$$\Sigma_{\underline{s}} := \Sigma_{s_1} \sqcup \dots \sqcup \Sigma_{s_k}.$$

This expression, $p_{1,2,\underline{s}}$ satisfies a locality property that is crucial for the following theorem

$$p_{1,2,\underline{s}} = p_{1,2,s_1} \cdots p_{1,2,s_k},$$

where $p_{1,2,s_i}$ denotes the ratio of $p(c'_i)$ and $p(c)$, with c'_i obtained from c by a $(1, 2)$ -Kempe move on Σ_{s_i} .

The above lemma allows us to prove:

THEOREM 2.3. The $GL(N)$ -foam evaluation $\langle F \rangle$ is a symmetric power series in the variables x_1, x_2, \dots, x_N . In particular, $\langle F \rangle$ is free of denominators.

PROOF. The proof of the above theorem is essentially a simple variation on the argument given in [RW1, Proposition 2.18]. Consider the expression $\langle F \rangle$. It is clear that it is symmetric in the variables x_1, x_2, \dots, x_N with possible denominators of the form $(x_i - x_j)^k$. By symmetry, the proof of the theorem will follow if we can show that the denominator $(x_1 - x_2)$ does not appear in $\langle F \rangle$.

Let us decompose the set of colorings of $\langle F \rangle$ into a collection of equivalence classes relative to the colors 1 and 2. Given a coloring c of F , decompose $F_{12}(c)$ into connected components,

$$F_{12}(c) = \Sigma = \Sigma_1 \cup \Sigma_2 \cup \dots \cup \Sigma_r.$$

The equivalence class of colorings C_c that contains c consists of colorings of F that can be obtained from c by performing Kempe moves about various connected components $\Sigma_s \subseteq F_{12}(c)$, where we recall that a Kempe move about Σ_s switches the colors 1 and 2 of the facets in Σ_s .

As in [RW1, Proposition 2.18], consider the expressions

$$P_{F/\Sigma}(F, c) = p(c) \prod_{f \text{ not a facet in } \Sigma} P(c(f)), \quad \tilde{Q}(F, c) = \frac{Q(F, c) \prod_{s,k \geq 2} (x_1 - x_k)^{l_{\Sigma_s}(c,k)/2}}{(x_1 - x_2)^{\chi_{12}(c)/2}}$$

where $p(c)$ is as defined in Lemma 2.1, and the integers $l_{\Sigma_s}(c, k)$ are as defined in [RW1, Lemma 2.10]. Also, for $1 \leq s \leq r$, define

$$T_s(F, c) = \widehat{P}_{\Sigma_s}(F, c) + (-1)^{\chi(\Sigma_s)/2} p_{1,2,s} \sigma(\widehat{P}_{\Sigma_s}(F, c)),$$

where σ is the transposition that swaps x_1 and x_2 , the term $p_{1,2,s}$ is as defined in Lemma 2.1, and the expression $\widehat{P}_{\Sigma_s}(F, c)$ is defined as

$$\widehat{P}_{\Sigma_s}(F, c) = \prod_{f \text{ a facet in } \Sigma_s} P(c(f)) \prod_{2 < k \leq N} (x_1 - x_k)^{l_{\Sigma_s}(c,k)/2}.$$

Using Lemma 2.1 and Remark 2.2, we may express the foam evaluation $\langle F, c \rangle$ on summing over the equivalence class C_c as

$$\sum_{c' \in C_c} \langle F, c' \rangle = (-1)^{s'(F,c)} \frac{P_{F/\Sigma}(F, c)}{\widetilde{Q}(F, c)} \prod_{s=1}^r (x_1 - x_2)^{-\chi(\Sigma_s)/2} T_s(F, c).$$

Since $\widetilde{Q}(F, c)$ is not divisible by $x_1 - x_2$, it is enough for our purposes to show that the expression $(x_1 - x_2)^{-\chi(\Sigma_s)/2} T_s(F, c)$ does not have a denominator given by a power of $x_1 - x_2$. The only case that is relevant is when Σ_s is a surface of genus zero. It is therefore sufficient to show that $T_s(F, c)$ is divisible by $(x_1 - x_2)$ when Σ_s is a surface of genus zero. In this case, we have

$$T_s(F, c) = \widehat{P}_{\Sigma_s}(F, c) - p_{1,2,s} \sigma(\widehat{P}_{\Sigma_s}(F, c)).$$

By Lemma 2.1, recall that $p_{1,2,s}$ is of the form $1 \pmod{(x_1 - x_2)}$. We therefore have

$$T_s(F, c) = \widehat{P}_{\Sigma_s}(F, c) - \sigma(\widehat{P}_{\Sigma_s}(F, c)) \pmod{(x_1 - x_2)}.$$

However, the expression $\widehat{P}_{\Sigma_s}(F, c) - \sigma(\widehat{P}_{\Sigma_s}(F, c))$ is also divisible by $x_1 - x_2$ since it switches sign under σ . It follows that $T_s(F, c)$ is divisible by $x_1 - x_2$ whenever Σ_s is a surface of genus zero. The proof of the theorem easily follows on summing $\langle F, c' \rangle$ over all the equivalence classes C_c . \square

3. Formal groups and generalized divided difference operators

In this section we study formal group laws and their relationship to topology in some detail. Good references are [Ha, St] and the references therein. Due to standard conventions the choice of notation R in this section conflicts with its use in the next section.

Let us begin by recalling the definition of a formal group law. A formal group law defined over a ring R is a power series $\mathcal{F}(x, y)$ with coefficients in R so that $\mathcal{F}(x, y)$ represents a commutative group structure on the formal affine line over R . In other words, one requires $\mathcal{F}(x, y)$ to satisfy the following three properties

$$\begin{aligned} \mathcal{F}(x, y) &= \mathcal{F}(y, x) && \text{commutativity} \\ \mathcal{F}(0, x) &= \mathcal{F}(x, 0) = x && \text{unitarity} \\ \mathcal{F}(x, \mathcal{F}(y, z)) &= \mathcal{F}(\mathcal{F}(x, y), z) && \text{associativity.} \end{aligned}$$

REMARK 3.1. *There is a universal ring known as the Lazard ring which is initial among all rings that support a formal group law. This ring L can be defined to be generated by symbols $a_{i,j}$ where the universal formal group law has the form*

$$\mathcal{F}(x, y) = x + y + \sum_{i,j > 0} a_{i,j} x^i y^j.$$

We then impose relations on the generators $a_{i,j}$ that are forced by the relations of commutativity and associativity (the relation for unitarity is built into the form of

$\mathcal{F}(x, y)$). For instance, commutativity implies that $a_{i,j} = a_{j,i}$. The relation for associativity is clearly more involved.

In topology, formal group laws appear when one describes the E -cohomology of a space $\mathrm{BU}(1)$, where E is any complex oriented cohomology theory and $\mathrm{BU}(1)$ denotes the classifying space of the group $\mathrm{U}(1)$ (the space $\mathrm{BU}(1)$ is equivalent to the infinite projective plane $\mathbb{C}\mathbb{P}^\infty$). More precisely, one starts with the observation that $E^*(\mathrm{BU}(1))$ can be expressed as $R[[x]]$, with $R = E^*(pt)$ and x being the first Chern class in cohomological degree 2. The abelian group structure on $\mathrm{U}(1)$ induces a map

$$\mathrm{BU}(1) \times \mathrm{BU}(1) \longrightarrow \mathrm{BU}(1).$$

Evaluating this map in E -cohomology then gives rise to the underlying a formal group law $\mathcal{F}_E(x, y)$ for the complex oriented cohomology theory E :

$$R[[x]] = E^*(\mathrm{BU}(1)) \longrightarrow E^*(\mathrm{BU}(1) \times \mathrm{BU}(1)) = R[[x, y]], \quad x \longmapsto \mathcal{F}_E(x, y).$$

In what follows therefore, we work in the graded setting. So $\mathcal{F}(x, y)$ will denote a formal group law over a graded power series ring $R[[x, y]]$, where R is a graded \mathbb{Z} -algebra, and the variables x and y are defined to have degree 2. We assume that $\mathcal{F}(x, y)$ is in homogeneous degree 2, namely

$$\mathcal{F}(x, y) = x + y + \sum_{i,j>0} a_{ij}x^i y^j, \quad a_{ij} \in R^{2-2(i+j)}.$$

DEFINITION 3.2. *The formal negative of the variable x is defined to be the (unique) power series $[-1]x$ with the property*

$$\mathcal{F}(x, [-1]x) = \mathcal{F}([-1]x, x) = 0.$$

The formal difference $x[-1]y$ is defined as $\mathcal{F}(x, [-1]y)$. It is a power series in two variables x, y that has homogeneous degree 2.

EXAMPLE 3.3. *Let R be the \mathbb{Z} -algebra $\mathbb{Z}[\beta]$, where β is in degree -2 . The multiplicative formal group law $\mathcal{F}(x, y)$ and its formal difference are given by*

$$\mathcal{F}(x, y) = x + y - \beta xy, \quad x[-1]y = \frac{x - y}{1 - \beta y}, \quad [-1](x) = -\sum_{i \geq 0} \beta^i x^{i+1}.$$

EXAMPLE 3.4. *Let R be the \mathbb{Z} -algebra $\mathbb{Z}[\beta^2]$ as before with β^2 in degree -4 . The Lorentz or L -formal group law $\mathcal{F}(x, y)$ and its formal difference are given by*

$$\mathcal{F}(x, y) = \frac{x + y}{1 + \beta^2 xy}, \quad x[-1]y = \frac{x - y}{1 - \beta^2 xy}, \quad [-1](x) = -x.$$

EXAMPLE 3.5. *Let R be the \mathbb{Z} -algebra $\mathbb{Z}[\frac{1}{2}, \beta^2]$ with β^2 in degree -4 . The \hat{A} -formal group law $\mathcal{F}(x, y)$ and its formal difference are given by*

$$\mathcal{F}(x, y) = x\sqrt{1 + \beta^2(y/2)^2} + y\sqrt{1 + \beta^2(x/2)^2},$$

$$x[-1]y = x\sqrt{1 + \beta^2(y/2)^2} - y\sqrt{1 + \beta^2(x/2)^2}, \quad [-1](x) = -x.$$

where the radicals are expressed as a power series (with coefficients in $\mathbb{Z}[\frac{1}{2}, \beta^2]$) by the formal application of the binomial expansion.

EXAMPLE 3.6. Let R be the \mathbb{Z} -algebra $\mathbb{Z}[\frac{1}{2}, \epsilon, \delta]$ with the degree of δ being -4 and that of ϵ being -8 . The Jacobi formal group law $\mathcal{F}(x, y)$ and its formal inverse are given by

$$\mathcal{F}(x, y) = \frac{x\sqrt{J(y)} + y\sqrt{J(x)}}{1 - \epsilon x^2 y^2}, \quad \text{where } J(z) = 1 - 2\delta z^2 + \epsilon z^4.$$

$$x[-1]y = \frac{x\sqrt{J(y)} - y\sqrt{J(x)}}{1 - \epsilon x^2 y^2}, \quad [-1](x) = -x.$$

Examples 3.4 and 3.5 are specializations of 3.6 at the ‘cusps’ described by $\epsilon = \beta^4, \delta = \beta^2$ and $\epsilon = 0, \delta = -\beta^2/8$ respectively.

Let us return to the universal example. In other words, we consider the example of R being the Lazard ring introduced earlier. On introducing a grading on the variables x and y so that the universal formal group law belongs in homogeneous degree 2, the Lazard ring naturally acquires a grading as described earlier. With this grading, the Lazard ring can be shown to be isomorphic to the graded coefficient ring of a complex oriented cohomology theory known as complex cobordism, MU . In other words $R \cong \text{MU}^*(pt)$ as a graded ring.

By the definition of complex cobordism, the elements of $\text{MU}^{-k}(pt)$ are cobordism classes of k -dimensional manifolds endowed with an almost complex structure on their stable normal bundle, and with the ring structure being induced by the cartesian product of manifolds. The ring $\text{MU}^*(pt)$ can be shown to be a polynomial algebra over \mathbb{Z} , with one generator in each negative even degree. Working rationally, the generator in degree $-2n$ may be chosen to be the cobordism class of the complex projective space of dimension $2n$, denoted by $[\mathbb{C}P^{2n}]$.

Any formal group law over a \mathbb{Q} -algebra is isomorphic to the additive formal group law. This isomorphism is called the logarithm, written as $\log_{\mathcal{F}}(x)$, and is the unique power series with leading term being x , that interpolates the given formal group law $\mathcal{F}(x, y)$ with the additive one $\mathbb{G}_a(x, y) = x + y$.

On extending scalars from \mathbb{Z} to \mathbb{Q} , the logarithm in the universal case has an explicit description

$$\log_{\text{MU}}(x) = \sum_{k \geq 0} \frac{[\mathbb{C}P^{2k}]}{k+1} x^{k+1}, \quad \text{so that } \log_{\text{MU}}(\mathcal{F}_{\text{MU}}(x, y)) = \log_{\text{MU}}(x) + \log_{\text{MU}}(y)$$

An immediate corollary of the above description is the following example.

EXAMPLE 3.7. Let R be the \mathbb{Z} -algebra $\text{MU}^*(pt)$. The universal formal group law $\mathcal{F}_{\text{MU}}(x, y)$ and its formal difference are given by

$$\mathcal{F}_{\text{MU}}(x, y) = \exp_{\text{MU}}(\log_{\mathcal{F}}(x) + \log_{\mathcal{F}}(y)) = \exp_{\text{MU}}\left(\sum_{k \geq 0} \frac{[\mathbb{C}P^{2k}]}{k+1} (x^{k+1} + y^{k+1})\right),$$

$$x[-1]y = \exp_{\text{MU}}\left(\sum_{k \geq 0} \frac{[\mathbb{C}P^{2k}]}{k+1} (x^{k+1} - y^{k+1})\right) = \exp_{\text{MU}}\left((x - y) \sum_{k \geq 0} \frac{[\mathbb{C}P^{2k}]}{k+1} S_k(x, y)\right),$$

where $\exp_{\text{MU}}(z)$ is the compositional inverse of $\log_{\text{MU}}(z)$, and $S_k(x, y)$ is the symmetric sum

$$S_k(x, y) = x^k + x^{k-1}y + \dots + xy^{k-1} + y^k.$$

Notice that even though the expressions for $\mathcal{F}_{\text{MU}}(x, y)$ and $x[-1]y$ above appear to have denominators, these denominators cancel away in the ring $\text{MU}^*(pt)$ once one expands the expression as a power series in x and y .

One may notice that the formal difference $x[-1]y$ in each of the above examples appears to be divisible by the expression $(x - y)$. In fact, this is always true as we now show

CLAIM 3.8. *Given an arbitrary formal group law, there is a unique homogeneous degree 0 element $q(x, y) \in R[[x, y]]$ so that*

$$x[-1]y = (x - y) \cdot q(x, y).$$

Furthermore, $q(x, y)$ is invertible and $q(x, y) \equiv 1 \pmod{(y)}$.

PROOF. Consider the formal expansion of the expression $(y+z)[-1]y := \mathcal{F}(y+z, [-1]y)$. On setting z as 0, we see that the expression vanishes. Therefore, it is divisible by z . Setting z as $(x - y)$, we conclude that there is a power series $q(x, y)$ that satisfies the relation

$$(x - y)q(x, y) := \mathcal{F}(y + x - y, [-1]y) = x[-1]y.$$

Since $(x - y)$ is not a zero divisor in $R[[x, y]]$, we see that $q(x, y)$ is unique. Next, by setting y as 0, we see that $q(x, 0) = 1$. In particular, $q(x, y)$ has the form $1 \pmod{(y)}$, and is therefore a unit. \square

REMARK 3.9. *It is not hard to show using the definition of the power series $q(x, y)$ that the coefficients in its expansion generate the same sub algebra of R as the coefficients of the formal group law $\mathcal{F}(x, y)$. To see this, first observe that the power series $[-1]y$ can be expressed in terms of the coefficients of $q(x, y)$ using the fact that $[-1]y = -yq(0, y)$. Next, observe that $\mathcal{F}(x, y) = x[-1]([-1]y) = (x - [-1]y)q(x, [-1]y)$. These two observations together establish what we seek to show.*

REMARK 3.10. *In example 3.6, one may verify that $q(x, y)$ is the following (symmetric) expression*

$$q(x, y) = \frac{x + y}{x\sqrt{J(y)} + y\sqrt{J(x)}}.$$

In general however, $q(x, y)$ need not be symmetric in x, y as is easily seen from example 3.3.

REMARK 3.11. *The universal example 3.7 allows us to deduce some interesting properties about $q(x, y)$. For instance, we see that $q(x, y)$ has the form*

$$q(x, y) = \sum_{k \geq 0} \frac{[\mathbb{C}P^k]}{k + 1} S_k(x, y) + \sum_{n \geq 1} q_n(x, y)(x - y)^n,$$

where $q_n(x, y)$ are symmetric power series in x and y . Note that each individual series $q_n(x, y)$ involves denominators. However, on setting $x = y$, those terms vanish and we obtain the interesting (universal) relation that does not involve denominators

$$q(x, x) = \frac{d}{dx} \log_{\mathcal{F}}(x).$$

CLAIM 3.12. *Assume that the \mathbb{Z} -algebra R is torsion free. Then, given a formal group law $\mathcal{F}(x, y)$ over R , the power series $q(x, y)$ is symmetric if and only if $\log_{\mathcal{F}}(x)$ is an odd power series. Equivalently, $q(x, y)$ is symmetric if and only if $q(x, x)$ is an even power series. Note that these conditions are automatic if R has no nontrivial elements in degrees $2 \pmod 4$.*

PROOF. The equivalence of the two conditions follows from remark 3.11 above. It remains to establish the first condition. Now $\log_{\mathcal{F}}(x)$ is an odd power series if and only if its compositional inverse $\exp_{\mathcal{F}}(x)$ is an odd power series. We will now proceed to show that symmetry of $q(x, y)$ is equivalent to $\exp_{\mathcal{F}}(x)$ being an odd power series. Using the universal example 3.7, we see that the formal difference $x[-1]y$ for the formal group law $\mathcal{F}(x, y)$ has the form

$$x[-1]y = \exp_{\mathcal{F}}(z), \quad z = (x - y)s(x, y),$$

with $s(x, y)$ being a symmetric power series

$$s(x, y) = \sum_{k \geq 0} \frac{l_k}{k+1} S_k(x, y), \quad \text{where} \quad \log_{\mathcal{F}}(x) = \sum_{k \geq 0} \frac{l_k}{k+1} x^{k+1}.$$

Note that $s(x, y)$ is invertible in $(R \otimes \mathbb{Q})[[x, y]]$, and so z can be chosen to be a power series generator. We therefore have an inclusion

$$(R \otimes \mathbb{Q})[[z]] \subset (R \otimes \mathbb{Q})[[x, y]], \quad z \mapsto (x - y)s(x, y).$$

It follows that $q(x, y) s(x, y)^{-1} = \exp_{\mathcal{F}}(z)/z$ is symmetric if and only if $\exp_{\mathcal{F}}(z)/z$ is even, or that $\exp_{\mathcal{F}}(z)$ is odd. \square

Let us now study the divided difference operators in the context of formal group laws.

DEFINITION 3.13. *Consider the formal power series ring $R[[x_1, x_2, \dots, x_n]]$. Let α denote any pair (i, j) for $1 \leq i < j \leq n$. We think of α as a positive root of $U(n)$ so that the pairs (i, j) are indexed by the set Δ_+ of positive roots of $U(n)$. Given a formal group law defined over R , we define the generalized divided difference operator A_α as the operator on $R[[x_1, x_2, \dots, x_n]]$*

$$A_\alpha(f) := \frac{f}{x_i[-1]x_j} + \frac{r_\alpha(f)}{x_j[-1]x_i}, \quad f \in R[[x_1, x_2, \dots, x_n]],$$

where r_α is the reflection on $R[[x_1, x_2, \dots, x_n]]$ given by switching x_i and x_j . Using elementary algebra, one can check that the operator A_α is well defined and does not involve denominators.

REMARK 3.14. *If E is a complex oriented cohomology theory with underlying formal group law \mathcal{F}_E and the coefficients of a point being $E^*(pt) = R$, then the operators A_α have a natural meaning in terms of push-pull operators on the $U(n)$ -equivariant E -cohomology ring of the flag variety $U(n)/T$ (see [BE]). More precisely, recall that the $U(n)$ -equivariant E -cohomology of a $U(n)$ -space X is defined as the E -cohomology of the space $EU(n) \times_{U(n)} X$ with $EU(n)$ being the principal contractible $U(n)$ -space. For $X = U(n)/T$, the $U(n)$ -equivariant E -cohomology ring is isomorphic to $R[[x_1, x_2, \dots, x_n]]$, supporting the operator A_α that is defined as the*

pushforward in equivariant E -cohomology followed by the pullback: $\pi^* \circ \pi_*$, where π denotes the $U(n)$ -equivariant fibration

$$\pi : U(n)/T \longrightarrow U(n)/U_\alpha(n),$$

with $U_\alpha(n)$ being the maximal compact subgroup in the parabolic subgroup corresponding to the positive root α .

CLAIM 3.15. Given a root $\alpha \in \Delta_+$ defined by the pair $(i < j)$, let $q(\alpha)$ denote the unit $q(x_i, x_j)$ as defined in 3.8. Then the intersection of the kernels of all the operators A_{α_i} , where $\alpha_i = x_i - x_{i+1}$ is a simple root, is a rank one free module over the ring of symmetric power series $R[[x_1, x_2, \dots, x_n]]^{\Sigma_n}$ generated by the unit $q(\Delta_+)$, where

$$q(\Delta_+) := \prod_{\alpha \in \Delta_+} q(\alpha).$$

PROOF. Given a simple root $\alpha_i \in \Delta_+$, let us rewrite the action of A_{α_i} on f as

$$A_{\alpha_i}(f) = \frac{f}{x_i[-1]x_{i+1}} + r_i\left(\frac{f}{x_i[-1]x_{i+1}}\right).$$

Hence f is in the kernel of A_{α_i} if the expression $\frac{f}{x_i[-1]x_{i+1}}$ switches sign under r_i . Notice that the ratio of any two such elements is invariant under r_i . On the other hand, by claim 3.8, it follows that given an r_i -invariant element g , the expression $q(\alpha_i)g$ is in the kernel of A_{α_i} . In particular, we have shown that for a fixed α_i , the kernel of A_{α_i} is *precisely* the rank one module of r_i invariants generated by the unit $q(\alpha_i)$. Now let us fix $\alpha_i \in \Delta_+$, and consider

$$\check{q}(\alpha_i) := \prod_{\beta \in \Delta_+, \beta \neq \alpha_i} q(\beta), \quad \text{so that} \quad q(\alpha_i)\check{q}(\alpha_i) = q(\Delta_+).$$

Since r_i permutes all positive roots besides α_i , we see that $\check{q}(\alpha_i)$ is an r_i -invariant unit. Hence the kernel of A_{α_i} is a rank one free module of r_i -invariants generated by the element $q(\Delta_+)$. Taking intersection over all simple roots $\alpha_i \in \Delta_+$ we get the required result. \square

EXAMPLE 3.16. For the multiplicative formal group law of example 3.3, the intersection of the kernels of all the generalized divided difference operators A_{α_i} is a rank one free module over symmetric power series $R[[x_1, x_2, \dots, x_n]]^{\Sigma_n}$ generated by the unit $q(\Delta_+)$, where

$$q(\Delta_+) = \frac{1}{(1 - \beta x_2)(1 - \beta x_3)^2 \dots (1 - \beta x_n)^{n-1}}.$$

Note that $q(\Delta_+)$ is not Σ_n -invariant for any $n > 1$.

Let D_α denote the classical divided difference operator (i.e. the divided difference operator for the additive formal group law). Definition 3.13 and claim 3.8 imply that we have

$$(3.1) \quad A_\alpha(f) = D_\alpha(q(\alpha)^{-1}f), \quad \text{in other words} \quad A_\alpha = D_\alpha \circ Q(\alpha)^{-1},$$

where $Q(\alpha)$ denotes the operator given by multiplication with $q(\alpha)$. In particular, the q -twisted operators $Q(\alpha_i) \circ A_{\alpha_i}$ satisfy the braid relations, and generate an

algebra isomorphic to the nilHecke algebra, namely, the algebra generated by the operators D_{α_i} . We also have

THEOREM 3.17. *Given a formal group law defined over R , let $\mathcal{A}(n)$ denote the algebra of operators on $R[[x_1, x_2, \dots, x_n]]$ generated by multiplication operators, and the generalized divided difference operators A_{α_i} for $1 \leq i < n$. Then $\mathcal{A}(n)$ is identically the same as the (completed) affine nilHecke algebra over the ground ring R . In other words, $\mathcal{A}(n)$ agrees with the algebra generated by the operators D_{α_i} and multiplication operators with respect to $R[[x_1, x_2, \dots, x_n]]$. In particular, $\mathcal{A}(n)$ is a free (left or right) module of rank $n!$ over the subalgebra $R[[x_1, x_2, \dots, x_n]]$. Alternatively, $\mathcal{A}(n)$ is a matrix algebra of rank $(n!)^2$ over the subalgebra $R[[x_1, x_2, \dots, x_n]]^{\Sigma_n}$. It follows that $R[[x_1, x_2, \dots, x_n]]^{\Sigma_n} \subset \mathcal{A}(n)$ is the center.*

PROOF. By (3.1), we see that the operators A_{α_i} are of the form $D_{\alpha_i} \circ Q(\alpha_i)^{-1}$, where $Q(\alpha_i)$ is the invertible multiplication operator corresponding to $q(\alpha_i)$. It follows that the operators A_{α_i} generate the same algebra as D_{α_i} when extended with multiplication operators, which is the affine nilHecke algebra by definition (once we complete polynomials to power series). The rest of the claim follows from well-known results on the affine nilHecke algebra. \square

REMARK 3.18. *The above theorem may come as a surprise to the reader, since it has been known for some time that for an arbitrary compact Lie group G , the push-pull operators A_{α_i} defined as in remark 3.14 and acting on the equivariant cohomology $E_G^*(G/T)$, do not satisfy the braid relations, unless the formal group law \mathcal{F}_E underlying the cohomology theory E is highly restrictive (see theorem 3.7 in [BE], see also [HMSZ]). It is possible that theorem 3.17 only holds for the compact Lie group $G = U(n)$, though we have not verified this. It is important to note that the classes $q(\alpha_i)$ that allow for the proof of the above theorem have been studied before (see [C], [Na]), though the main observation of theorem 3.17 appears to be new.*

4. Deformed $GL(2)$ foam evaluation

4.1. $GL(2)$ foams and their colorings. The original formulation [Kh1] of $SL(2)$ link homology did not use foams. Hints at foams appeared in the work of Clark, Morrison, and Walker [CMW] and Caprau [Ca1, Ca2], who used disorientation lines on surfaces involved in the construction of $SL(2)$ homology to control minus signs that appear throughout the theory. This allowed them to establish full functoriality of the theory under cobordisms rather than the functoriality up to an overall minus sign, as shown in the earlier work [J, Kh3, BN]. One can think of disorientation lines as remnants of the 2-facets of $GL(2)$ foams along which they were attached to the 1-facets.

Earliest constructions of $SL(3)$ and $SL(N)$ link homology for $N > 3$ used foams explicitly [Kh2] and implicitly [KRo2].

Blanchet [B] pioneered the use of foams for the $SL(2)$ (more precisely, $GL(2)$) homology theory. A detailed exploration of various flavours of $GL(2)$ foams and applications can be found in [EST1, EST2].

We find its useful to follow the $GL(2)$ foam calculus of Beliakova, Hogancamp, Putyra, Wehrli [BHPW]. That is the calculus deformed in this section.

We consider $GL(2)$ foams (or, simply, foams) in this paper. A closed $GL(2)$ foam F is a combinatorial compact two-dimensional CW-complex embedded in \mathbb{R}^3

(or \mathbb{S}^3). The only allowed singularities of the CW-complex are *singular circles*, such that any point on the circle has a neighbourhood homeomorphic to the product of the tripod and the interval.

The set of points of F on its singular circles is denoted $s(F)$, and connected components of $F \setminus s(F)$ are called *facets*. Facets of F are subdivided into 1-facets and 2-facets. One-facets are also called *thin* facets, two-facets are also called *double* or *thick* facets. We require that along each singular circle two 1-facets and one 2-facet meet, see Figure 4.11.

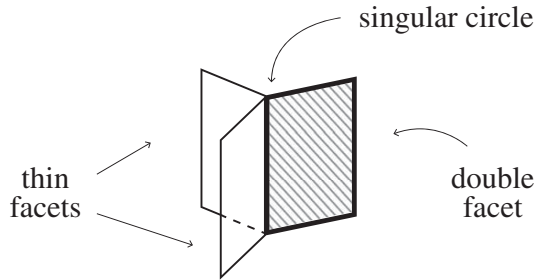

FIGURE 4.11. Part of a singular circle and its neighbourhood, with two thin and one double facet.

This implies, in particular, that no 'monodromy' is possible along any singular circle, so it has a neighbourhood in F homeomorphic to the product of \mathbb{S}^1 and a tripod with 'two thin legs and a double leg'.

Each facet is oriented in such a way that all three facets along any singular circle induce a compatible orientation on this circle, see Figure 4.12. In most diagrams that follow, it is clear whether a facet is thin or double, and we usually omit the corresponding label 1 or 2.

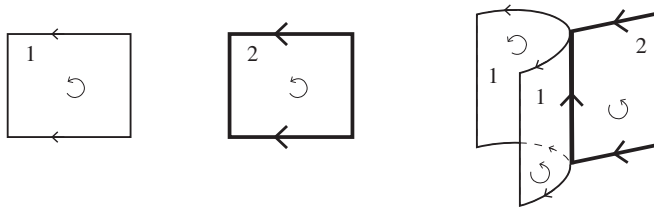

FIGURE 4.12. Left: oriented think and thick facets, with induced orientations on the top and bottom boundary. Right: compatibility between orientations of a singular circle and adjacent thin facets and the double facet. Also shown induced orientations of the top and bottom foam's boundary. They will be needed when we pass from closed foams to foams with boundary in Section 4.6.

Thin facets may carry dots, which can move freely along a facet, but cannot jump to an adjacent facet. If a facet carries n dots, we may record them as a single

dot with label n . It is possible to allow similar decorations on 2-facets, namely symmetric polynomials in two variables, but we avoid doing so in the paper, instead moving any such decoration from a 2-facet to the coefficient of the foam.

Remark: Unlike $GL(N)$ foams for $N \geq 3$ and $SL(N)$ foams for $N \geq 4$, $GL(2)$ foams can not have singular vertices.

A *coloring* (or *admissible coloring*) of a foam F is a map c from the set of its thin facets to the set $\{1, 2\}$ such that along any singular circle, the two thin facets are mapped to different numbers. It is convenient to extend c to double facets, coloring each double facet by the set $\{1, 2\}$. This produces the flow condition, that the union of colors of 1-facets along each singular circle is the color of the double facet, that is, the entire set $\{1, 2\}$.

Notice that $F_{12}(c)$ does not depend on the coloring c and is a closed surface which is the union of closures of 1-facets of F . We denote it by F_{12} and call the *thin surface* of F . Likewise, $F_{1\cap 2}(c)$ does not depend on c and is the union of closures of 2-facets of F . We denote it by $F_{1\cap 2}$ and call the *double surface* of F . The boundary of $F_{1\cap 2}$ is exactly the set of singular circles of F .

Often it is convenient to identify a facet f with its closure \bar{f} in F . In particular, the Euler characteristics of f and \bar{f} are equal, since the two spaces differ only by a union of circles, which is the boundary of \bar{f} . From now on, unless otherwise specified, by a facet we mean a closed facet.

Surface F_{12} has finitely many connected components $\Sigma_1, \dots, \Sigma_n$. Each component may contain one or more singular circles. The union of these singular circles is zero when viewed as an element of $H_1(\Sigma_k, \mathbb{Z}/2)$, for any k , due to our orientation requirements on F . In particular, each Σ_k admits exactly two checkerboard colorings of its regions, where along each singular circle in Σ_k the coloring is reversed.

A choice of such coloring for each Σ_k is equivalent to a coloring of F . Hence, F has 2^n colorings, where n is the number of connected components of F_{12} .

Quantity $\theta^+(c) = \theta_{12}^+(c)$ counts the number of positive circles for a coloring c , see Figure 4.13.

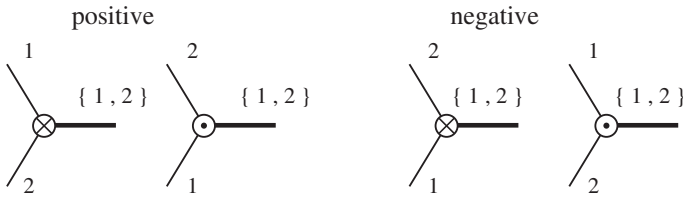

FIGURE 4.13. $\theta_{12}^+(c)$ or simply $\theta^+(c)$ counts the number of positive circles.

4.2. Deformed evaluation for $GL(2)$ foams. Modified Robert-Wagner evaluation formula, in the $GL(2)$ case, specializes to

$$(4.1) \quad \langle F, c \rangle = (-1)^{\theta_{12}^+(c)} \frac{(x_1 - x_2)^{\chi(F_{1\cap 2}(c))} x_1^{d_1(c)} x_2^{d_2(c)}}{(x_1[-1]x_2)^{\chi_1(c)/2} (x_2[-1]x_1)^{\chi_2(c)/2}}$$

Since

$$(4.2) \quad x_1[-1]x_2 = (x_1 - x_2)p_{12}^{-1}, \quad x_2[-1]x_1 = (x_2 - x_1)p_{21}^{-1},$$

we have

$$(4.3) \quad \frac{(x_1 - x_2)^{\chi_{1\cap 2}(c)}}{(x_1[-1]x_2)^{\chi_1(c)/2}(x_2[-1]x_1)^{\chi_2(c)/2}} = (-1)^{\chi_2(c)/2} \frac{p_{12}^{\chi_1(c)/2} p_{21}^{\chi_2(c)/2}}{(x_1 - x_2)^{\chi_{12}(c)/2}}$$

In the 2-color case, $F_{1\cap 2}(c) = F_{1\cap 2}$ is the union of facets of thickness two and does not depend on c . Likewise, $F_{12}(c) = F_{12}$ does not depend on c either. Its Euler characteristic is denoted $\chi_{12}(F) = \chi(F_{12})$.

Equation (4.1) can be rewritten

$$\begin{aligned} \langle F, c \rangle &= (-1)^{\theta_{12}^+(c) + \chi_2(c)/2} \frac{x_1^{d_1(c)} x_2^{d_2(c)}}{(x_1 - x_2)^{\chi(F_{12})/2} p_{12}^{-\chi_1(c)/2} p_{21}^{-\chi_2(c)/2}} \\ &= (-1)^{\theta_{12}^+(c) + \chi_2(c)/2} \frac{x_1^{d_1(c)} x_2^{d_2(c)} p_{12}^{\chi_1(c)/2} p_{21}^{\chi_2(c)/2}}{(x_1 - x_2)^{\chi(F_{12})/2}} \\ &= (-1)^{s'(F,c)} \frac{P(F, c)}{Q(F, c)} p_{12}^{\chi_1(c)/2} p_{21}^{\chi_2(c)/2} \\ &= (-1)^{\chi(F)/2} \langle F, c \rangle_{RW} p_{12}^{\chi_1(c)/2} p_{21}^{\chi_2(c)/2}. \end{aligned}$$

Above, $s'(F, c) = \theta_{12}^+(c) + \chi_2(c)/2$ and $d_1(c), d_2(c)$ is the number of dots on thin facets colored by 1, resp. 2 by c . We see that the original evaluation $\langle F, c \rangle_{RW}$ is scaled by an invertible element, which is a product of powers of p_{12} and p_{21} and a sign. Also, the power of $x_1 - x_2$ in the denominator depends on F only. Let us write down the formula again.

$$(4.4) \quad \langle F, c \rangle = (-1)^{\theta_{12}^+(c) + \chi_2(c)/2} \frac{x_1^{d_1(c)} x_2^{d_2(c)} p_{12}^{\chi_1(c)/2} p_{21}^{\chi_2(c)/2}}{(x_1 - x_2)^{\chi(F_{12})/2}}$$

We now define

$$(4.5) \quad \langle F \rangle = \sum_c \langle F, c \rangle,$$

the sum over all colorings of F . Let $E_1 = x_1 + x_2, E_2 = x_1 x_2$. The symmetric group S_2 acts on $\mathbf{k}[[x_1, x_2]]$ by permuting x_1, x_2 .

THEOREM 4.1. $\langle F \rangle \in \mathbf{k}[[x_1, x_2]]^{S_2} \cong \mathbf{k}[[E_1, E_2]]$ for any $GL(2)$ foam F .

In other words, $\langle F \rangle$ is a power series in x_1, x_2 that is symmetric under the permutation action of S_2 on x_1, x_2 . Equivalently, it is a power series in elementary symmetric functions E_1, E_2 . Consider the chain of inclusions

$$(4.6) \quad \mathbf{k} \subset \mathbf{k}[[E_1, E_2]] \subset \mathbf{k}[[x_1, x_2]] \subset \mathbf{k}[[x_1, x_2]] \left[\frac{1}{x_1 - x_2} \right].$$

Denote these rings by

$$(4.7) \quad \tilde{R} = \mathbf{k}[[E_1, E_2]],$$

$$(4.8) \quad R' = \mathbf{k}[[x_1, x_2]],$$

$$(4.9) \quad R'' = \mathbf{k}[[x_1, x_2]] \left[\frac{1}{x_1 - x_2} \right],$$

resulting in the chain of ring inclusions

$$(4.10) \quad \mathbf{k} \subset \tilde{R} \subset R' \subset R''.$$

The theorem above has already been proved in Section 2 for general N , see Theorem 2.3. We include a more detailed proof for the special case $N = 2$ to make this section independent from Section 2.

PROOF. The evaluation $\langle F, c \rangle$ can be written, via (4.1), as a power series in x_1, x_2 with coefficients in \mathbf{k} divided by a power of $x_1 - x_2$, either positive or negative, thus it belongs to the ring R'' , see above.

Group S_2 acts on 2-colorings of F by transposing the colors 1 and 2. This action is compatible with the evaluation in the sense that $\sigma(\langle F, c \rangle) = \langle F, \sigma(c) \rangle$, where $\sigma = (12)$ is the nontrivial element of S_2 . Therefore, $\langle F \rangle$ is in the subring $(R'')^{S_2}$ of S_2 -invariants of R'' .

$\langle F \rangle$ potentially has a denominator $(x_1 - x_2)^{\chi(F_{12}(c))/2}$. Surface $F_{12}(c) = F_{12}$ is a union of connected components $\Sigma_1, \dots, \Sigma_m$, each one contributing $(x_1 - x_2)^{\chi(\Sigma_k)/2}$ to the product. Only connected components of genus 0 have positive Euler characteristic, $\chi(\Sigma_k) = 2$, and contribute $x_1 - x_2$ to the denominator.

Consider one such component Σ and a coloring c . The Kempe move on Σ replaces c with a coloring $c_1 = (c, \Sigma)$ which is identical to c outside Σ and swaps colors 1, 2 of c on Σ . We compare $\langle F, c \rangle$ and $\langle F, c_1 \rangle$ in formula (4.4).

If there are t_i dots on color i facets of Σ under c , $i = 1, 2$, then

$$x_1^{d_1(c)} x_2^{d_2(c)} = x_1^{t_1} x_2^{t_2} u, \quad x_1^{d_1(c_1)} x_2^{d_2(c_1)} = x_1^{t_2} x_2^{t_1} u,$$

for a monomial u in x_1, x_2 counting dots on facets not in Σ .

If Σ has r singular circles, let $\theta^+(c, \Sigma)$ be the number of positive circles on Σ under c and $\theta^-(c, \Sigma)$ be the number of negative circles. Under the swap $c \leftrightarrow c_1$, positive circles on Σ become negative circles on Σ and vice versa, so that $\theta^+(c, \Sigma) + \theta^+(c_1, \Sigma) = r$.

Let $\tilde{\chi}_i(\Sigma) = \chi(\Sigma \cap F_i(c))$, $i = 1, 2$, be the Euler characteristic of the union of color i facets of Σ , for coloring c . We have

$$\chi_2(c_1) = \chi_2(c) + \tilde{\chi}_1(\Sigma) - \tilde{\chi}_2(\Sigma) = \chi_2(c) + \chi(\Sigma) - 2\tilde{\chi}_2(\Sigma),$$

since $\chi(\Sigma) = \tilde{\chi}_1(\Sigma) + \tilde{\chi}_2(\Sigma)$. Defining integer ℓ by $2\ell = \tilde{\chi}_2(\Sigma) - \tilde{\chi}_1(\Sigma)$, we have

$$\chi_2(c_1) = \chi_2(c) - 2\ell, \quad \chi_1(c_1) = \chi_1(c) + 2\ell.$$

Consequently, one can write

$$p_{12}^{\chi_1(c_1)/2} p_{21}^{\chi_2(c_1)/2} = p_{12}^\ell u', \quad p_{12}^{\chi_1(c)/2} p_{21}^{\chi_2(c)/2} = p_{21}^\ell u',$$

for a suitable monomial u' in p_{12}, p_{21} , possibly with negative exponents.

Also,

$$\frac{(-1)^{s'(F, c_1)}}{(-1)^{s'(F, c)}} = \frac{(-1)^{\theta^+(c_1) + \chi_2(c_1)/2}}{(-1)^{\theta^+(c) + \chi_2(c)/2}} = (-1)^{r + \chi(\Sigma)/2 - \tilde{\chi}_2(\Sigma)}.$$

When $\Sigma \cong \mathbb{S}^2$,

$$r + \chi(\Sigma)/2 - \tilde{\chi}_2(\Sigma) \equiv 1 + r - \tilde{\chi}_2(\Sigma) \equiv 1 \pmod{2},$$

since $r \equiv \tilde{\chi}_2(\Sigma) \pmod{2}$. The last comparison modulo 2 can be proved by induction on r , by removing an innermost singular circle of Σ . This operation reduces r by 1 and changes $\tilde{\chi}_2(\Sigma)$ by ± 1 . We see that $(-1)^{s'(F, c_1)} = -(-1)^{s'(F, c)}$.

Putting these relations together,

$$\langle F, c \rangle + \langle F, c_1 \rangle = (-1)^{s'(F,c)} \cdot (x_1^{t_1} x_2^{t_2} p_{21}^\ell - x_1^{t_2} x_2^{t_1} p_{12}^\ell) uu'(x_1 - x_2)^{-\chi_{12}(F)/2}.$$

The expression $(x_1^{t_1} x_2^{t_2} p_{21}^\ell - x_1^{t_2} x_2^{t_1} p_{12}^\ell)$ is divisible by $x_1 - x_2$ and allows to cancel out that term from the denominator.

Repeating this argument simultaneously for all \mathbb{S}^2 -components of F_{12} shows that $\langle F \rangle \in \mathbf{k}[[x_1, x_2]]$. Permutation action of S_2 on $\mathbf{k}[[x_1, x_2]]$ and on colorings shows that $\langle F \rangle \in \mathbf{k}[[x_1, x_2]]^{S_2} = \mathbf{k}[[E_1, E_2]]$. \square

The sum $\chi(F) = \chi_1(c) + \chi_2(c)$ does not depend on the coloring c and is the Euler characteristic of the surface F . In particular, in the symmetric case (when $p_{12} = p_{21}$), one has that

$$(4.11) \quad \langle F \rangle = \langle F \rangle_{RW} \cdot (-p_{12})^{\chi(F)/2}$$

so that the new evaluation is proportional to the original one with the coefficient that depends only on $\chi(F)$. We expect that non-symmetric case will prove more interesting.

4.3. Examples.

Example 1: Let $F = \mathbb{S}_{1,n}^2$ be the two-sphere of thickness one with n dots (or, equivalently, with a single dot labelled n). Here the lower index $(1, n)$ lists thickness followed by the number of dots.

$\mathbb{S}_{1,n}^2$ has two colorings c_1 and c_2 , where in the coloring c_i the 2-sphere carries color i . For the coloring c_1

$$F_1(c_1) \cong \mathbb{S}^2, \quad F_2(c_1) = \emptyset, \quad F_{1 \cap 2}(c_1) = \emptyset,$$

and likewise for c_2 , so that

$$\langle \mathbb{S}_{1,n}^2, c_1 \rangle = \frac{x_1^n}{x_1[-1]x_2} = \frac{x_1^n p_{12}}{x_1 - x_2},$$

$$\langle \mathbb{S}_{1,n}^2, c_2 \rangle = \frac{x_2^n}{x_2[-1]x_1} = \frac{x_2^n p_{21}}{x_2 - x_1},$$

and

$$\langle \mathbb{S}_{1,n}^2 \rangle = \frac{x_1^n p_{12} - x_2^n p_{21}}{x_1 - x_2}.$$

To explicitly cancel $x_1 - x_2$ in the denominator, expand p_{12} and p_{21} into power series and then cancel. The result is a power series symmetric in x_1, x_2 with coefficients which are polynomials in $\beta_{i,j}$.

We denote

$$(4.12) \quad \rho_n = \langle \mathbb{S}_{1,n}^2 \rangle = \frac{x_1^n p_{12} - x_2^n p_{21}}{x_1 - x_2}.$$

Note that the following relation holds:

$$(4.13) \quad \rho_{n+2} - E_1 \rho_{n+1} + E_2 \rho_n = 0,$$

where, recall, $E_1 = x_1 + x_2$, $E_2 = x_1 x_2$. It follows from the relation

$$(x_1^{n+2} p_{12} - x_2^{n+2} p_{21}) - (x_1 + x_2)(x_1^{n+1} p_{12} - x_2^{n+1} p_{21}) + x_1 x_2 (x_1^n p_{12} - x_2^n p_{21}) = 0.$$

Relation (4.13) allows to inductively write $\rho_n = \langle \mathbb{S}_{1,n}^2 \rangle$ as a linear combination of $\rho_0 = \langle \mathbb{S}_{1,0}^2 \rangle$ and $\rho_1 = \langle \mathbb{S}_{1,1}^2 \rangle$ with coefficients in $\mathbb{Z}[[E_1, E_2]]$. The latter are

$$(4.14) \quad \rho_0 = \langle \mathbb{S}_{1,0}^2 \rangle = \frac{p_{12} - p_{21}}{x_1 - x_2}, \quad \rho_1 = \langle \mathbb{S}_{1,1}^2 \rangle = \frac{x_1 p_{12} - x_2 p_{21}}{x_1 - x_2}.$$

Example 2: Let the foam F be a thin two-torus T^2 with n dots and standardly embedded in \mathbb{R}^3 (embedding of a surface does not influence its evaluation). As in the previous example, there are two colorings, c_1 and c_2 , with $F_1(c_1) \cong T^2$, $F_2(c_1) = \emptyset$, $F_{1\cap 2}(c_1) = \emptyset$, and $\langle T^2 \rangle = x_1^n + x_2^n$.

Example 3: Closed surface M of genus $g \geq 1$ with n dots.
 (4.15)

$$\langle M \rangle = \frac{x_1^n p_{12}^{1-g}}{(x_1 - x_2)^{1-g}} + \frac{x_2^n p_{21}^{1-g}}{(x_2 - x_1)^{1-g}} = (x_1^n p_{12}^{1-g} + (-1)^{g-1} x_2^n p_{21}^{1-g})(x_1 - x_2)^{g-1}.$$

Example 4: F is 2-sphere \mathbb{S}^2 of thickness two, also denoted \mathbb{S}_2^2 . It has a unique coloring c , with the facet labelled by $\{1, 2\}$ and $F_1(c) = F_2(c) = F_{1\cap 2}(c) \cong \mathbb{S}^2$ so that

$$\begin{aligned} \langle \mathbb{S}_2^2 \rangle &= \langle \mathbb{S}_2^2, c \rangle = \frac{(x_1 - x_2)^2}{(x_1[-1]x_2)(x_2[-1]x_1)} = \frac{(x_1 - x_2)^2 p_{12} p_{21}}{(x_1 - x_2)(x_2 - x_1)} \\ &= -p_{12} p_{21} \end{aligned}$$

Denote the value of this foam by ρ , so that

$$(4.16) \quad \rho = \langle \mathbb{S}_2^2 \rangle = -p_{12} p_{21}.$$

Note that ρ is an invertible element of the ground ring. In the original case, when $p(x, y) = 1$, the double sphere \mathbb{S}_2^2 evaluates to -1 .

Example 5: An oriented closed surface M of genus $g \geq 1$ and thickness two:

$$(4.17) \quad \langle M \rangle = \frac{(x_1 - x_2)^{2-2g} p_{12}^{1-g} q_{21}^{1-g}}{(x_1 - x_2)^{1-g} (x_2 - x_1)^{1-g}} = (-p_{12} p_{21})^{1-g} = \rho^{1-g}.$$

In the special case, when $g = 1$ so that $M = T^2$ is a two-torus, $\langle T_2^2 \rangle = 1$.

Example 6: The theta-foam Θ with n_1 and n_2 dots on thin facets, suitably oriented.

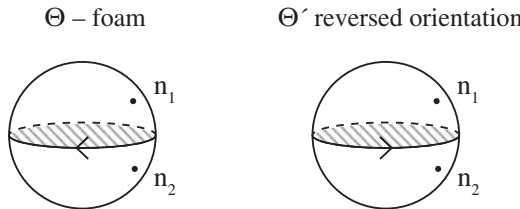

FIGURE 4.31. On the left: Θ -foam. On the right: same foam Θ' with the reversed orientation.

Let c_1 be the coloring of Θ with its top facet colored 1. Then the bottom facet is colored 2. Surfaces $F_1(c_1)$, $F_2(c_1)$, and $F_{12}(c_1) = F_{12}$ are all 2-spheres, with Euler characteristics 2. The sign $\theta_{12}^+(c_1) = 1$.

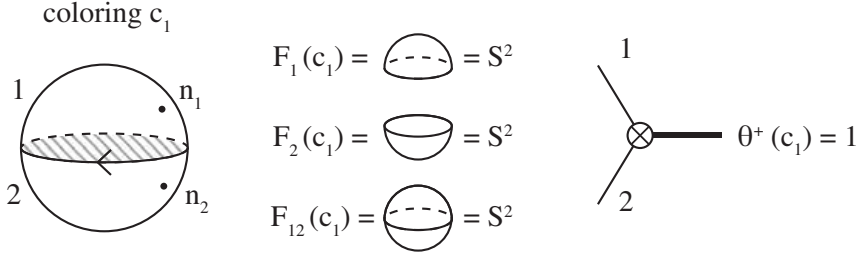

FIGURE 4.32. Computing $\langle \Theta, c_1 \rangle$.

For the sign,

$$s'(\Theta, c_1) = \theta^+(c_1) + \chi_2(c_1)/2 = 1 + 1 = 2, \quad (-1)^{s'(\Theta, c_1)} = 1.$$

We get

$$\langle \Theta, c_1 \rangle = \frac{x_1^{n_1} x_2^{n_2} p_{12} p_{21}}{x_1 - x_2}, \quad \langle \Theta, c_2 \rangle = \frac{-x_1^{n_2} x_2^{n_1} p_{12} p_{21}}{x_1 - x_2},$$

where c_2 is the other coloring (with the opposite sign in the evaluation and transposed exponents of x_1, x_2). Assuming $n_1 \geq n_2$,

(4.18)

$$\langle \Theta \rangle = (x_1 x_2)^{n_2} \frac{x_1^{n_1 - n_2} - x_2^{n_1 - n_2}}{x_1 - x_2} p_{12} p_{21} = (x_1 x_2)^{n_2} h_{n_1 - n_2 - 1}(x_1, x_2) p_{12} p_{21},$$

where $h_k(x_1, x_2) = x_1^k + x_1^{k-1} x_2 + \dots + x_2^k$ is the k -th complete symmetric function in x_1, x_2 . Note that we can write

(4.19)

$$\langle \Theta \rangle = -E_2^{n_2} h_{n_1 - n_2 - 1}(x_1, x_2) \rho,$$

and that $h_k(x_1, x_2)$ is a polynomial in E_1, E_2 , the latter elementary symmetric functions in x_1, x_2 . Also, $\langle \Theta \rangle$ is the product of a Schur function for $GL(2)$ and $-\rho$.

Note that if the two thin facets of the theta-foam carry the same number of dots, $n_1 = n_2$, then it evaluates to zero, $\langle \Theta \rangle = 0$. If we reverse the orientation of Θ to get a foam Θ' , then $\langle \Theta' \rangle = -\langle \Theta \rangle$. In general, if foam F contains k singular circles and \overline{F} is given by reversing the orientation of F , then $\langle \overline{F} \rangle = (-1)^k \langle F \rangle$.

Recall that our ground ring R is the power series $\mathbf{k}[[E_1, E_2]]$, where $\mathbf{k} = \mathbb{Z}[\beta_{i,j}]$ is polynomials in various negative degree generators with integer coefficients, see formulas (2.7), (4.7). Let R be the subring of $\tilde{R} = \mathbf{k}[[E_1, E_2]]$ generated by $E_1, E_2, \rho_0, \rho_1, \rho^{\pm 1}$ over \mathbb{Z} :

(4.20)

$$R = \langle E_1, E_2, \rho_0, \rho_1, \rho^{\pm 1} \rangle \subset \tilde{R} = \mathbf{k}[[E_1, E_2]].$$

In all the examples above, the foam evaluates to an element of this subring. We will see soon that this is true for any closed foam and that the ground ring of the theory can be reduced from the rather large power series ring $\mathbf{k}[[E_1, E_2]]$ to the subring R , which is finitely generated over the image of \mathbb{Z} in \mathbf{k} .

Let us summarize that

$$\begin{aligned}
 \rho_0 &= \langle \mathbb{S}_{1,0}^2 \rangle = \frac{p_{12} - p_{21}}{x_1 - x_2}, \\
 \rho_1 &= \langle \mathbb{S}_{1,1}^2 \rangle = \frac{x_1 p_{12} - x_2 p_{21}}{x_1 - x_2}, \\
 \rho &= \langle \mathbb{S}_{2,0}^2 \rangle = -p_{12} p_{21}
 \end{aligned}
 \tag{4.21}$$

are the evaluations of the thin 2-sphere with zero dots, with one dot, and the double 2-sphere, respectively. The subring R is graded, with homogeneous generators in degrees

generator	ρ_0	ρ_1	ρ	E_1	E_2
degree	-2	0	0	2	4

Notice that only ρ_0 has a negative degree. Using that $E_1^2 - 4E_2 = (x_1 - x_2)^2$, it is easy to compute

$$\rho_1^2 - E_1 \rho_1 \rho_0 + E_2 \rho_0^2 = \frac{E_1^2 - 4E_2}{(x_1 - x_2)^2} p_{12} p_{21} = -\rho.
 \tag{4.22}$$

Define the ring

$$\overline{R} = \mathbb{Z}[E_1, E_2, \rho_0, \rho_1, (\rho_1^2 - E_1 \rho_1 \rho_0 + E_2 \rho_0^2)^{-1}]
 \tag{4.23}$$

as the localization of the polynomial ring with generators E_1, E_2, ρ_0, ρ_1 at the element

$$\rho = -(\rho_1^2 - E_1 \rho_1 \rho_0 + E_2 \rho_0^2).
 \tag{4.24}$$

There is an obvious homomorphism $\overline{R} \rightarrow R \subset \widetilde{R}$, and we now prove that it is an isomorphism between \overline{R} and R .

Consequently, we can think of R as the localization,

$$R \cong \mathbb{Z}[E_1, E_2, \rho_0, \rho_1, (\rho_1^2 - E_1 \rho_1 \rho_0 + E_2 \rho_0^2)^{-1}].
 \tag{4.25}$$

We will show that this localization has a basis over $\mathbb{Z}[E_1, E_2]$:

$$\mathcal{B} := \{\rho_1^{n_1} \rho_0^{n_2} \rho^{n_3}, \quad n_1 \in \{0, 1\}, n_2 \in \mathbb{Z}_+, n_3 \in \mathbb{Z}\}
 \tag{4.26}$$

To establish isomorphism $\overline{R} \cong R$ of rings, denote by

$$R^- := \mathbb{Z}[\rho_0, \rho_1^{\pm 1}][[E_1, E_2]]
 \tag{4.27}$$

the graded ring of power series in E_1, E_2 with coefficients in the ring $\mathbb{Z}[\rho_0, \rho_1^{\pm 1}]$. In this definition, we view ρ_0, ρ_1 as additional generators and not as power series.

LEMMA 4.2. *Ring R^- is naturally a subring of \widetilde{R} , via power series expansions (4.21) for ρ_0 and ρ_1 .*

PROOF. We can write the power series

$$p_{12} = 1 + Ax_1 + Bx_2 + \sum_{i+j>1} \beta_{ij} x_1^i x_2^j,$$

where $A = \beta_{1,0}$ and $B = \beta_{0,1}$, also see formula (2.4). The power series for ρ_1 is invertible, since the expansion starts with $1 + A(x_1 + x_2) = 1 + AE_1$ followed by higher degree terms in x_1 and x_2 with coefficients in the variables β_{ij} for $i + j > 1$,

$$\rho_1 \mapsto \frac{x_1 p_{12} - x_2 p_{21}}{x_1 - x_2} = 1 + A(x_1 + x_2) + h.o.t.,$$

where *h.o.t.* stands for 'higher order terms'. Furthermore, the series expansion for ρ_1 does not involve the coefficient B . The series

$$\rho_0 \longmapsto \frac{p_{12} - p_{21}}{x_1 - x_2} = A - B + h.o.t.$$

begins with the element $A - B$ followed by higher degree terms in x_1 and x_2 with coefficients only involving the parameters β_{ij} for $i + j > 1$. Consider the homomorphism

$$\tau : R^- = \mathbb{Z}[\rho_0, \rho_1^{\pm 1}][[E_1, E_2]] \longrightarrow \tilde{R},$$

given by expanding ρ_0 and ρ_1 as power series, so that

$$\tau(\rho_0) = A - B + h.o.t., \quad \tau(\rho_1) = 1 + AE_1 + h.o.t.$$

To show that τ is injective, compose τ with the involution of \tilde{R} that sends the generator $B = \beta_{0,1}$ to $\tau(\rho_0)$, and fixes all other generators (generators E_1, E_2 and $\beta_{i,j}$ for $(i, j) \neq (0, 1)$). So the question reduces to showing injectivity of the map

$$\pi : R^- \longrightarrow \tilde{R}, \quad \pi(\rho_0) = B, \quad \pi(\rho_1) = \tau(\rho_1) = 1 + AE_1 + h.o.t., \quad \pi(E_i) = E_i, \quad i = 1, 2.$$

Now consider any homogeneous element of degree $2n$ in the kernel of π

$$\sum_{i,j,k, i+2j=n+k} \rho_0^k f_{ijk}(\rho_1) E_1^i E_2^j,$$

where $f_{ijk}(\rho_1)$ is a Laurent polynomial in ρ_1 . Mapping to \tilde{R} under π and observing that the elements B^k are linearly independent over the subring of \tilde{R} given by power series in E_1 and E_2 with values in the polynomial algebra $\mathbb{Z}[\beta_{i,j}, (i, j) \neq (0, 1)]$, we deduce that for any fixed $k \geq 0$ one has relations

$$0 = \sum_{i+2j=2n+k} f_{ijk}(\tau(\rho_1)) E_1^i E_2^j.$$

Notice that for any k , the above expression is a finite sum. So by multiplying by a suitable power of $\tau(\rho_1)$, we may assume that each Laurent polynomial $f_{ijk}(\rho_1)$ is in fact a polynomial in ρ_1 . The algebraic independence of the classes $\tau(\rho_1), E_1, E_2$ easily implies that each $f_{ijk}(\rho_1)$ must be trivial. In other words, the map π is injective, which is what we wanted to prove. \square

COROLLARY 4.3. *The power series homomorphism $\overline{R} \longrightarrow \tilde{R}$ takes \overline{R} isomorphically onto the subring R of \tilde{R} . Moreover, the ring R has a basis over $\mathbb{Z}[E_1, E_2]$ given by*

$$\mathcal{B} := \{\rho_1^{n_1} \rho_0^{n_2} \rho^{n_3}, \quad n_1 \in \{0, 1\}, n_2 \in \mathbb{Z}_+, n_3 \in \mathbb{Z}\}.$$

PROOF. By definition, the image of \overline{R} in \tilde{R} is equal to the ring R . Now both rings \overline{R} and R are generated as modules over $\mathbb{Z}[E_1, E_2]$ by the set of elements of \mathcal{B} . To be more precise, both rings \overline{R} and R have a collection of generators $\mathcal{B}(\overline{R})$ and $\mathcal{B}(R)$, respectively, as defined above that are compatible under the map from \overline{R} to R . Hence, to demonstrate the isomorphism between \overline{R} and R , it is sufficient to show that the elements $\mathcal{B}(R)$ are linearly independent over $\mathbb{Z}[E_1, E_2]$ when seen as elements in R , thereby showing that the elements $\mathcal{B}(R)$ form a $\mathbb{Z}[E_1, E_2]$ -module basis of R . It follows from this that the collection $\mathcal{B}(\overline{R})$ also forms a $\mathbb{Z}[E_1, E_2]$ -module basis of \overline{R} , and consequently, that the map from \overline{R} to R is an isomorphism.

In what follows, we will actually show that the elements $\mathcal{B}(R)$ are linearly independent over $\mathbb{Z}[[E_1, E_2]]$ in the larger ring R^- , once we observe that the ring R

is contained in the image of $R^- \subset \tilde{R}$. For this it suffices to show that ρ^{-1} is in R^- , which follows from formula (4.22) that expresses ρ^{-1} as a power series in E_1 and E_2 with polynomial coefficients in $\rho_0, \rho_1^{\pm 1}$:

$$\rho^{-1} = -(\rho_1^2 - E_1\rho_1\rho_0 + E_2\rho_0^2)^{-1} = -\rho_1^{-2}(1 - E_1\rho_0\rho_1^{-1} + E_2\rho_0^2\rho_1^{-2})^{-1},$$

and then formally expanding the inverse as a power series. This shows that the inclusion $R \subset \tilde{R}$ factors through the subring R^- .

It remains to show linear independence of the elements $\mathcal{B}(R)$ over $\mathbb{Z}[[E_1, E_2]]$ inside R^- . Since the set of elements $\{\rho_0^{n_2}\}$ are linearly independent over $\mathbb{Z}[[E_1, E_2]]$, it is sufficient to show that the sub-collection of $\mathcal{B}(R)$ given by the elements $\{\rho_1^{n_1}\rho^{n_3}\}$ is linearly independent over $\mathbb{Z}[\rho_0][[E_1, E_2]]$. Let us consider a homogeneous relation

$$(4.28) \quad 0 = \sum_{n:=(n_1, n_3)} A_n(\rho_0, E_1, E_2)\rho_1^{n_1}\rho^{n_3},$$

where the indexing set is some finite subset of distinct pairs $n := (n_1, n_3)$ as above with $A_n(\rho_0, E_1, E_2)$ being a homogeneous element of $\mathbb{Z}[\rho_0][[E_1, E_2]]$. Reducing relation (4.28) mod ρ_0 and using equation (4.22), we obtain the relation in $\mathbb{Z}[\rho_1^{\pm 1}][[E_1, E_2]]$

$$0 = \sum_{n:=(n_1, n_3)} (-1)^{n_3} A_n(0, E_1, E_2)\rho_1^{n_1+2n_3},$$

which is clearly true only if $A_n(0, E_1, E_2) = 0$ for all n . This condition implies that each $A_n(\rho_0, E_1, E_2)$ is divisible by ρ_0 . We may therefore factor ρ_0 out of the entire relation (4.28), and repeat the argument (note that ρ_0 is not a zero divisor). This shows that $A_n(\rho_0, E_1, E_2)$ must be trivial for all n , which is what we needed to establish. □

REMARK 4.4. *The inclusion $R \subset R^-$ is dense in the power series ring topology. In order to show this, it is sufficient to show that ρ_1^{-1} can be described in terms of a power series in E_1 and E_2 , with coefficients that are polynomials in $\rho_0, \rho_1, \rho^{\pm 1}$. This follows from formula (4.22) which implies that*

$$\rho_1^{-1} = -\rho^{-1}(1 + \rho_0^2\rho^{-1}E_2)^{-1}(\rho_1 - \rho_0E_1).$$

Notice that in addition to the chain of ring inclusions in formulas (4.6)-(4.10), there is also a chain of inclusions

$$(4.29) \quad R \subset \tilde{R} \subset R' \subset R''.$$

The example 6 above for the evaluation of the Θ -foam is straightforward to generalize to $GL(N)$, where Θ -foam has a disk of thickness N with N disks of thickness one attached to it, carrying n_1, \dots, n_N dots, respectively, where we can assume $n_1 \geq n_2 \geq \dots \geq n_N$, see Figure 4.33.

Let $\lambda_i = n_i - N + i$, so that $\lambda = (\lambda_1, \dots, \lambda_N)$ is a partition iff $n_i > n_{i+1}$ for all i . Denote this foam by Θ_λ . One can compute the foam evaluation

$$(4.30) \quad \langle \Theta_\lambda \rangle = \pm \sum_{\sigma \in S_N} \frac{(-1)^{\ell(\sigma)} \prod_{i=1}^N x_{\sigma(i)}^{n_i}}{\prod_{i < j} (x_i - x_j)} \prod_{i \neq j} p_{ij} = \pm s_\lambda \prod_{i \neq j} p_{ij},$$

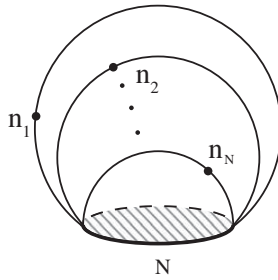

FIGURE 4.33. Θ -foam for $GL(N)$.

where s_λ is the $GL(N)$ Schur function for the partition λ . The last equality holds if λ is a partition, otherwise $\langle \Theta_\lambda \rangle = 0$. One can argue that our deformation does not go far enough, since it does not deform Schur functions in an interesting way and only scales them by the product of p_{ij} 's. At least it does deform the value of the thin 2-sphere with dots and other closed surfaces in a non-trivial way.

4.4. Skein relations.

PROPOSITION 4.5. *The skein relation (singular neck-cutting relation) in Figure 4.41 holds.*

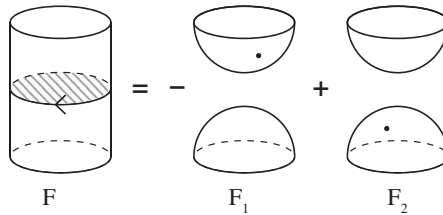

FIGURE 4.41. Singular neck-cutting relation.

Proof: Coloring c of F induces a coloring c' of F_1, F_2 (the latter two foams differ only by dot placement, and we use c' to denote corresponding coloring of both foams). Coloring c' has opposite colors on the two disks of F_1 (and F_2). If a coloring c_1 of F_1 and F_2 has the same color on the two disks, $\langle F_1, c_1 \rangle = \langle F_2, c_1 \rangle$, since dots will contribute with the same $x_i, i \in \{1, 2\}$, to the evaluations, and this coloring will not contribute to the difference $\langle F_2 \rangle - \langle F_1 \rangle$. Thus, we can restrict to colorings c' as above, in bijection with colorings c of F .

If the top facet of c is colored 1, see Figure 4.42, then the circle of F in the figure is positive and $\theta^+(c) = \theta^+(c') + 1$. Also, $\chi_2(F, c) = \chi_2(F_1, c') = \chi_2(F_2, c')$, so that $-(-1)^{s'(F,c)} = (-1)^{s'(F_1,c')} = (-1)^{s'(F_2,c')}$.

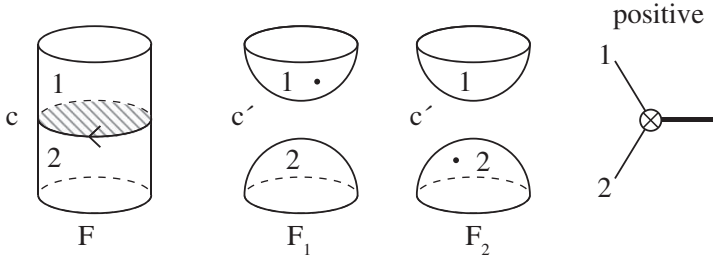

FIGURE 4.42. When top facet is colored 1.

We have $\chi_{12}(F, c) = \chi_{12}(F_1, c') - 2$, so that $\langle F, c \rangle$ has an additional $(x_1 - x_2)$ in the numerator, compared to $\langle F_1, c' \rangle$ and $\langle F_2, c' \rangle$. Due to a dot on facet colored 1 there is an extra x_1 in $\langle F_1, c' \rangle$ and an extra x_2 in $\langle F_2, c' \rangle$. More accurately, we can write

$$\langle F, c \rangle = -(x_1 - x_2)y, \quad \langle F_1, c' \rangle = x_1y, \quad \langle F_2, c' \rangle = x_2y$$

for some y , so that $\langle F, c \rangle = -\langle F_1, c' \rangle + \langle F_2, c' \rangle$.

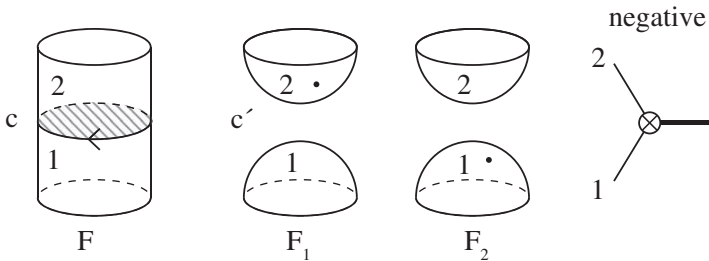

FIGURE 4.43. When top facet is colored 2.

The other case is when the top facet of F is colored 2 by c , see Figure 4.43. In this case the singular circle of F in the figure is negative for the coloring c , so that $\theta^+(c) = \theta^+(c')$ and $s'(F, c) = s'(F_1, c') = s'(F_2, c')$. This change of sign is balanced by the opposite coloring of the two disks in F_1, F_2 , so that

$$\langle F, c \rangle = (x_1 - x_2)y, \quad \langle F_1, c' \rangle = x_2y, \quad \langle F_2, c' \rangle = x_1y$$

for some y , and we still have $\langle F, c \rangle = -\langle F_1, c' \rangle + \langle F_2, c' \rangle$. Summing over all c implies the proposition. \square

Reversing the orientation of the singular circle (and hence of the entire connected component of F) changes the signs in the relation, see Figure 4.44 and Proposition 4.9 below.

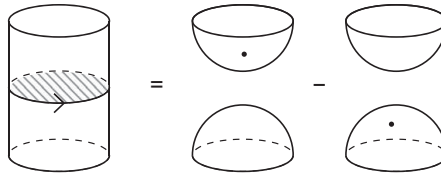

FIGURE 4.44. Relation for the other orientation.

PROPOSITION 4.6. *The skein relation (canceling double disks) in Figure 4.45 holds.*

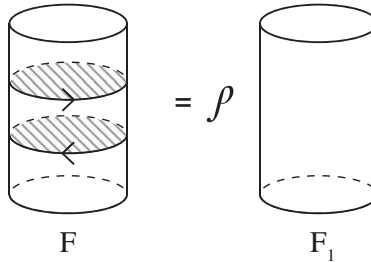

FIGURE 4.45. Canceling parallel double disks.

Proof: There is a bijection between colorings c of F and colorings c_1 of F_1 , see Figure 4.46.

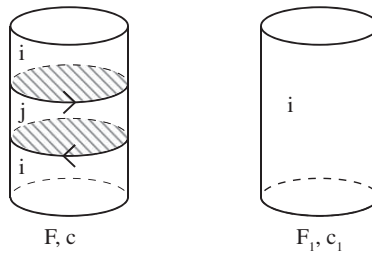

FIGURE 4.46. A coloring c of F and the corresponding coloring c_1 of F_1 .

One checks that $\chi_k(F_1, c_1) = \chi_k(F, c) - 2$, $k = 1, 2$, and $\chi_{12}(F, c) = \chi_{12}(F_1, c_1)$. For any coloring, $\theta^+(c') \equiv \theta^+(c) \pmod{2}$, since the two singular circles in F_1 have the same parity, and $(-1)^{s'(F,c)} = -(-1)^{s'(F_1,c_1)}$. Comparing the contributions,

$$\langle F, c \rangle = -p_{12}p_{21} \langle F_1, c_1 \rangle = \rho \langle F_1, c_1 \rangle.$$

Summing over all c , the result follows. \square

Since ρ is invertible, this relation shows that either of the two foams in Figure 4.45 can be written as the other foam times $\rho^{\pm 1}$.

Reversing orientation of the two singular circles on the left hand side of Figure 4.45 gives a similar skein relation, with no sign added since the parity of the number of singular circles is the same on both sides of the relation.

PROPOSITION 4.7. *The skein relation (neck-cutting relation) in Figure 4.47 holds.*

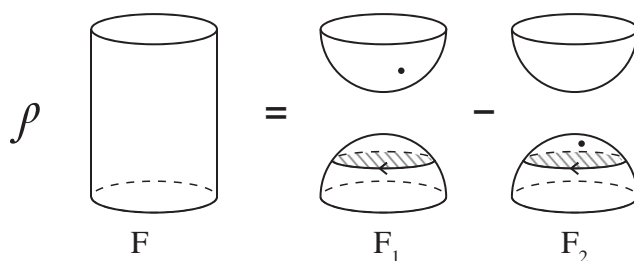

FIGURE 4.47. Neck-cutting relation.

Again, that ρ is invertible, and the relation allows us to do a surgery on an annulus which is part of a thin facet of F .

Proof: Apply Figure 4.45 relation to pass to a tube with two double disks and then use Figure 4.44 relation to do surgery on the top double disk. \square

Doing the surgery on the bottom double disk using Figure 4.41 results in a similar relation, depicted in Figure 4.48 where singular disks now appear at the top rather than the bottom on the right hand side.

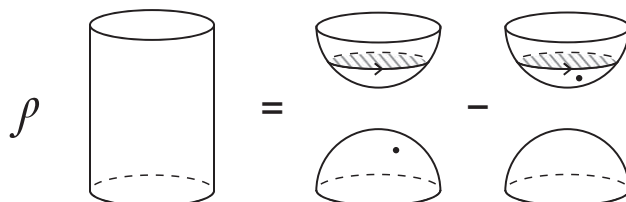

FIGURE 4.48. Neck-cutting relation with double disks at the top.

PROPOSITION 4.8. *If a double disk D^2 bounding a singular circle in a foam F can be completed to a 2-sphere without additional intersections with F , denote by*

F_1 the foam given by removing the 2-disk from F and adding its complement in S^2 , see Figure 4.49. Then $\langle F \rangle = -\langle F_1 \rangle$.

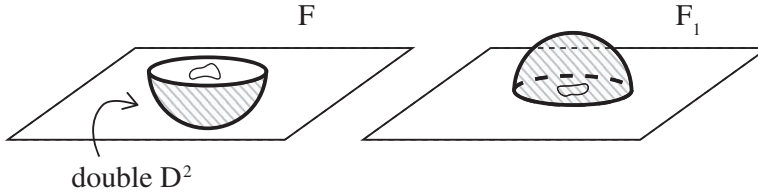

FIGURE 4.49. Double disk flipping.

Proof: There is a bijection between colorings c of F and colorings c_1 of F_1 , with the only difference in evaluations coming from the type of the singular circle, so that $s'(F, c) = s'(F_1, c_1) \pm 1$ and $\langle F, c \rangle = -\langle F_1, c_1 \rangle$. \square

PROPOSITION 4.9. If \overline{F} is a foam F with the reversed orientation of all facets, then $\langle \overline{F} \rangle = (-1)^k \langle F \rangle$, where k is the number of singular circles of F .

Proof: Each coloring c of F is a coloring of \overline{F} as well, and $\langle \overline{F}, c \rangle = (-1)^k \langle F, c \rangle$, since $s'(\overline{F}, c) = (-1)^k s'(F, c)$ as the type (positive or negative) of each singular circle of F is reversed in \overline{F} . Summing over c implies the proposition. \square

This proposition can be applied, for instance, to the neck-cutting relation in Figure 4.47. Reversing the orientation of singular circles in F_1, F_2 reverses the orientation of all facets as well. Since F has one less singular circle than F_1, F_2 , there'll be an additional overall minus sign, which can go either to the left or right hand side.

PROPOSITION 4.10. For a foam F_2 with a facet with two dots, the relation

$$\langle F_2 \rangle = E_1 \langle F_1 \rangle - E_2 \langle F_0 \rangle$$

holds, where F_1 and F_0 are the foams with one fewer and two fewer dots on the same facet, see Figure 4.410.

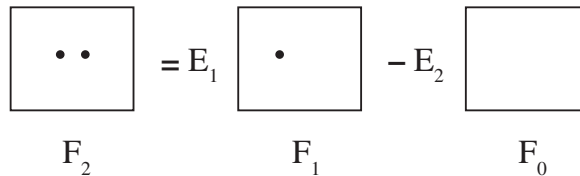

FIGURE 4.410. Dot reduction relation.

Proof: Follows, since $x_i^2 = E_1 x_i - E_2$ for $i = 1, 2$. \square

PROPOSITION 4.11. (*Double facet neck-cutting relation*) Evaluations of foams F and F_1 in Figure 4.411 satisfy $\langle F \rangle = \rho \langle F_1 \rangle$.

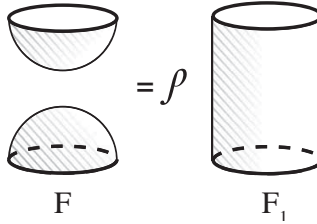

FIGURE 4.411. Neck cutting on a double facet.

Proof: Again, there is a bijection between colorings c of F and colorings c_1 of F_1 . Difference in the Euler characteristics $\chi_i(F, c) = \chi_i(F_1, c_1) + 2$, for $i = 1, 2$, contributes the term $-p_{12}p_{21} = \rho$ to the evaluation of $\langle F, c \rangle$ compared to that of $\langle F_1, c_1 \rangle$. Summing over c implies the proposition. \square

PROPOSITION 4.12. (*Dot migration relations*)

- (1) Evaluations of foams F_1, F_2 and F_1 in Figure 4.412 satisfy $\langle F_1 \rangle + \langle F_2 \rangle = E_1 \langle F \rangle$.
- (2) Figure 4.413 relation holds.

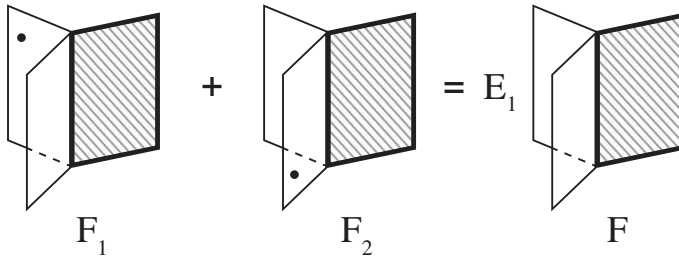

FIGURE 4.412. Dot migration relation.

Proof: Follows, since these foams differ only by dot placement, any for any coloring c the two facets with dots carry opposite colors. These dots contribute x_1 and x_2 to the evaluation. Consequently,

$$\langle F_1, c \rangle + \langle F_2, c \rangle = (x_1 + x_2) \langle F_3, c \rangle = E_1 \langle F_3, c \rangle$$

The same argument implies the second relation. \square

PROPOSITION 4.13. *Skein relation in Figure 4.414 holds.*

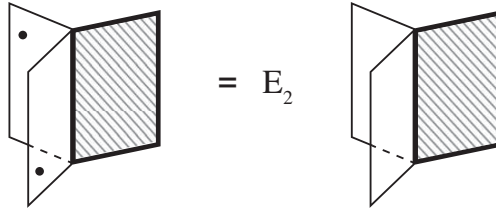

FIGURE 4.413. Second dot migration relation.

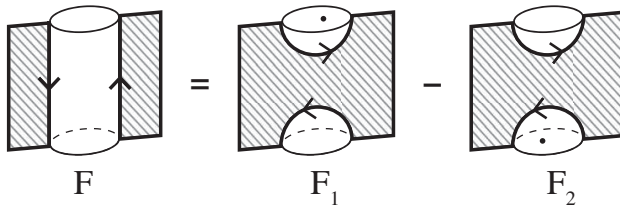

FIGURE 4.414. Cutting a tube with two singular edges.

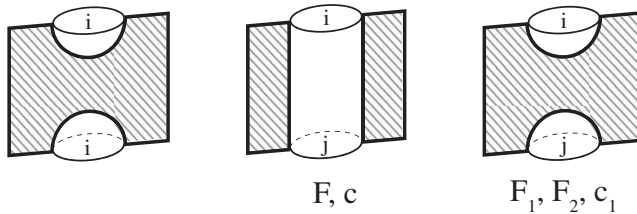

FIGURE 4.415. Left: a coloring of F_1, F_2 that does not come from a coloring of F . Right: a coloring c' of F and induced coloring c_1 of F_1, F_2 .

Proof: Colorings c' of F_1, F_2 that do not come from colorings of F have the property that the front thin bottom and back thin top facets are colored by the same color, see Figure 4.415 left.

The dots on F_1, F_2 will have the same color and these terms will cancel out from the difference, with $\langle F_1, c' \rangle - \langle F_2, c' \rangle = 0$.

The remaining colorings c_1 of F_1, F_2 are in bijection with colorings c of F , see Figure 4.415 right. For these colorings we have

$$\chi_{12}(F, c) = \chi_{12}(F_k, c_1) - 2, \quad \chi_\ell(F, c) = \chi_\ell(F_k, c_1), \quad \ell, k = 1, 2.$$

The rest of the computation is similar to that in the proof of Proposition 4.7. If $i = 1, j = 2$, one checks that $\theta^+(c_1) = \theta^+(c)$ and the signs $(-1)^{s'}$ are the same in the three evaluations. Due to difference in χ_{12} , the evaluation $\langle F, c \rangle$ will acquire $(x_1 - x_2)$ in the numerator compared to the other two foams. This will be matched by the dots, contributing x_1 to $\langle F_1, c_1 \rangle$ and x_2 to $\langle F_2, c_1 \rangle$, correspondingly.

If $i = 2, j = 1$, there will be sign difference $(-1)^{s'(F,c)} = -(-1)^{s'(F_k,c_1)}$, $k = 1, 2$. Dots will now contribute x 's with the opposite indices to the evaluations of F_1, F_2 , canceling the sign difference, so that again $\langle F, c \rangle = \langle F_1, c_1 \rangle - \langle F_2, c_1 \rangle$. \square

This relation with the opposite singular circles orientation, see Figure 4.416, can be obtained from that in Figure 4.414 by looking at foams there from the opposite side of the plane. Furthermore, rotating foams in Figure 4.414 by 180° (and using dot migration relation in Figure 4.412 twice) yields a similar to Figure 4.414 relation but with a different distribution of dots across thin facets.

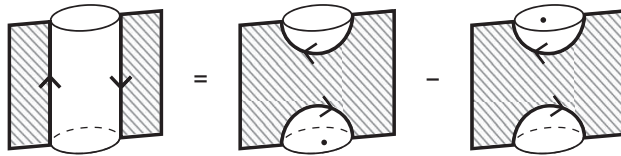

FIGURE 4.416. Tube-cutting with the other orientation.

In a foam F , let γ be a curve that connects two points on singular lines and lies in a single facet of F , see Figure 4.417 left. Let us call such a curve a *proper* curve. The foam $F_1 = m(\gamma, F)$ on that figure on the right is called the modification of F along γ . In the undeformed case, when $p(x, y) = 1$, $GL(2)$ foam evaluation satisfies $\langle F \rangle = \pm \langle F_1 \rangle$, with the sign depending on orientation of singular edges of F , see [BHPW, Equation (2.10)].

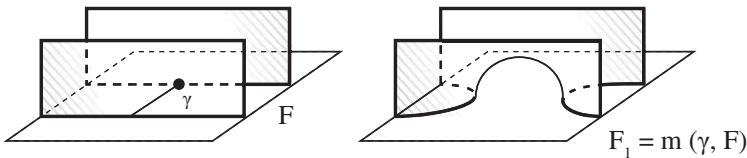

FIGURE 4.417. Modifying foam F along curve γ in a thin facet. γ connects two points on the singular set of F .

The relation is more subtle in our case. We start with orientations of singular edges as shown on Figure 4.418; note that choosing orientation of one edge forces the orientation of the other edge of F shown. Choose a coloring c of F and denote by c' the corresponding coloring of F_1 (there is a bijection between colorings of F and F_1), see Figure 4.418.

We have

$$\chi_{12}(F_1, c_1) = \chi_{12}(F, c), \quad \chi_i(c_1) = \chi_i(c) - 2, \quad \chi_j(c_1) = \chi_j(c).$$

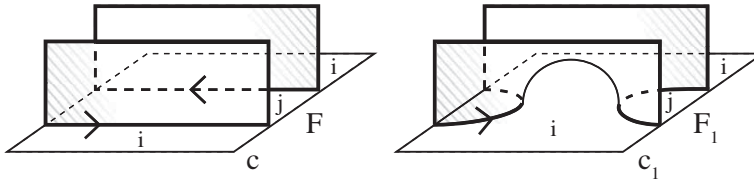

FIGURE 4.418. Notice orientation of singular edges.

The number of singular circles of F_1 is one less or more of that of F , depending on whether the two singular edges shown in F belong to different or the same singular circle.

If $i = 1, j = 2$ then these circles are negative, they make no contribution to $\theta^+(c)$ and $\theta^+(c_1)$, and $s'(F, c) = s'(F_1, c_1)$, since $\chi_2(c) = \chi_2(c_1)$ and $\theta^+(c) = \theta^+(c_1)$. If $i = 2, j = 1$, the circles are positive and $(-1)^{\theta^+(c)} = -(-1)^{\theta^+(c_1)}$. Also, the Euler characteristics $\chi_2(c), \chi_2(c_1)$ differ by two and contribute a sign to the difference as well. We again get $s'(F, c) = s'(F_1, c_1)$, so that for any coloring $s'(F, c) = s'(F_1, c_1)$.

Combining these computations,

$$(4.31) \quad \langle F, c \rangle = p_{ij} \langle F', c' \rangle.$$

Note that p_{ij} is not an element of our ground ring $\mathbf{k}[[E_1, E_2]]$ and summing this equality over all colorings c of F will not get an immediate relation between evaluations of F and F' .

We now look at the oppositely oriented case, see Figure 4.419. Circles now carry opposite signs from that of the previous case, and one can check that $s'(F, c) = -s'(F_1, c_1)$ in each of the cases $(i, j) = (1, 2)$ and $(i, j) = (2, 1)$. A similar compu-

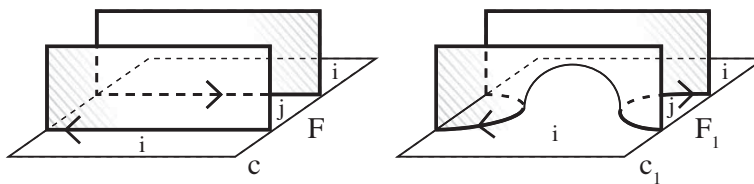

FIGURE 4.419. Singular edges have the opposite orientation from that in the previous figure.

tation now gives

$$(4.32) \quad \langle F, c \rangle = -p_{ij} \langle F_1, c_1 \rangle,$$

which is similar to (4.31) but with an additional sign.

Consider the thin surface F_{12} of F and choose a connected component Σ in it. Recall that we are looking at modifications of F along proper curves γ and now restrict to γ on a component Σ . Notice that the double facets at the endpoints of γ are pointing in the same direction relative to Σ , either both outward or both

inward. Also, if we were to redraw F in Figure 4.418 keeping orientations of the singular edges but drawing double facets on the opposite side of Σ ('below', rather than 'above'), the type of the diagram would change to the one in Figure 4.419, and vice versa.

Proper disjoint curves or arcs $\gamma_1, \gamma_2 \in \Sigma$ are called *complementary* if for a coloring c of F they lie in differently colored regions. This property does not depend on the choice of c .

To a pair (γ_1, γ_2) of complementary arcs we assign a sign $s(\gamma_1, \gamma_2)$. Namely, consider the four double facets of F at the endpoints of γ_1 and γ_2 . If these four facets all point into the same connected component of $\mathbb{R}^3 \setminus \Sigma$, we set $s(\gamma_1, \gamma_2) = 1$. Otherwise we define $s(\gamma_1, \gamma_2) = -1$.

An example when $s(\gamma_1, \gamma_2) = 1$ is shown in Figure 4.420. In general, γ_1, γ_2 don't have to have an endpoint on the same singular circle.

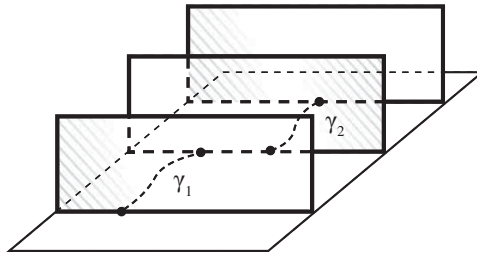

FIGURE 4.420. Complementary proper arcs γ_1, γ_2 with $s(\gamma_1, \gamma_2) = 1$.

Given complementary proper arcs γ_1, γ_2 in Σ , we can do commuting modifications along γ_1, γ_2 to get from F to the foam

$$F_2 = m(\gamma_1, m(\gamma_2, F)) = m(\gamma_2, m(\gamma_1, F)).$$

PROPOSITION 4.14. For F and F_2 as above, $\langle F \rangle = s(\gamma_1, \gamma_2) \rho \cdot \langle F_2 \rangle$.

Proof: For a coloring c of F curves γ_1 and γ_2 lie in differently colored regions of Σ , say i and j -colored regions, $\{i, j\} = \{1, 2\}$. When $s(\gamma_1, \gamma_2) = 1$, orientations on singular edges will make one of the curves γ the type in Figure 4.418 and the other in Figure 4.419, with (i, j) replaced by (j, i) in one of these two cases. Using equations (4.31) and (4.32), we obtain $\langle F, c \rangle = -p_{12}p_{21} \langle F_2, c_2 \rangle = \rho \langle F_2, c_2 \rangle$ for the corresponding coloring c_2 of F_2 .

When $s(\gamma_1, \gamma_2) = -1$, orientations on singular edges will make both γ_1, γ_2 either the type in Figure 4.418 or the type in Figure 4.419, with (j, i) in place for (i, j) for one of γ_1, γ_2 . This will introduce a minus sign, with $\langle F, c \rangle = -\rho \langle F_2, c_2 \rangle$. \square

This proposition may be generalized in some cases when one of γ_1, γ_2 is not a proper arc. One would need γ_2 to be a proper arc in $m(\gamma_1, F)$, in the region of color opposite to that of γ_1 , with a coloring of F naturally converted to a coloring of $m(\gamma_1, F)$. We provide an example of such pair of arcs in Figure 4.421 and leave the details to the reader.

COROLLARY 4.15. $\langle F \rangle = \rho \langle F_1 \rangle$ for foams F, F_1 in Figure 4.422.

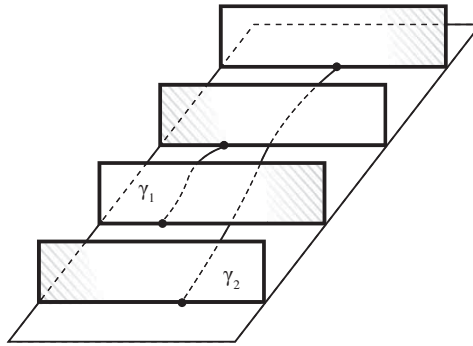

FIGURE 4.421. Arc γ_2 is not proper but becomes proper in $m(\gamma_1, F)$.

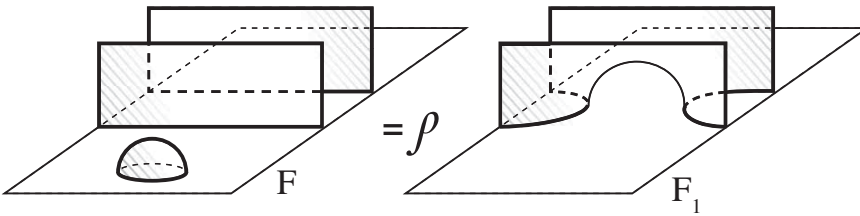

FIGURE 4.422. Notice additional double cap on the foam F , used to create a pair of complementary proper arcs on it.

This follows from Proposition 4.14 using the pair of arcs in Figure 4.423 with $s(\gamma_1, \gamma_2) = 1$. \square

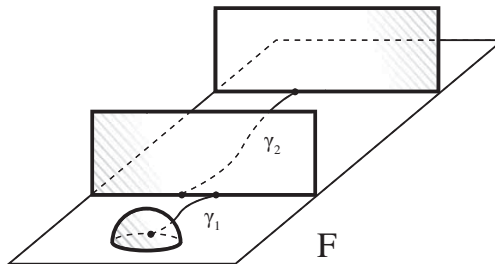

FIGURE 4.423. Arcs γ_1, γ_2 are complementary proper with $s(\gamma_1, \gamma_2) = 1$.

COROLLARY 4.16. *Figure 4.424 relation on foam evaluations holds.*

The corollary follows at one from the previous one. \square

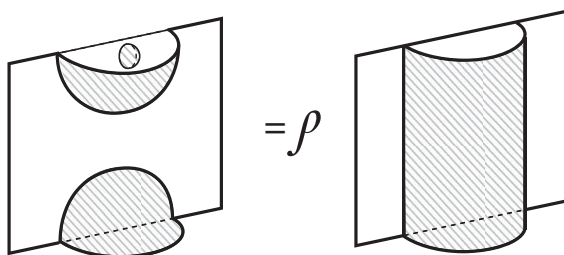

FIGURE 4.424. The bubble on the thin plane on the LHS foam points its double facet toward us, being on the same side of the thin plane as portions of the other double facets shown on the LHS.

4.5. Pre-foams and ground ring reduction.

To prove Proposition 4.19 below, it is convenient to introduce the notion of a $GL(2)$ pre-foam and its evaluation. An (oriented) $GL(2)$ pre-foam (or prefoam) F has the same local structure as a $GL(2)$ foam, but without an embedding into \mathbb{R}^3 . It has oriented thin and double facets, with the orientation of facets being compatible along singular edges as in Figure 4.12. In particular, orientations of facets induce orientations of singular circles. Vice versa, an orientation of a singular circle in a connected component of a pre-foam will induce orientations on all facets of that component.

Along each singular edge a preferred facet out of two adjacent thin facets is specified. One can encode this choice by an arrow (a normal direction) out of the singular edge and into the thin surface of the pre-foam (the union of its thin facets). A pre-foam may carry dots on its thin facets.

A $GL(2)$ foam F gives rise to a $GL(2)$ pre-foam, also denoted F . Embedding of foam F in \mathbb{R}^3 together with orientation of singular circles induces an order on the two thin facets attached to a given singular circle. Namely, look in the direction of the orientation on the circle and choose the first thin facet counterclockwise starting from the double facet attached to the circle. This is then the preferred facet for the singular circle in the underlying pre-foam F .

Coloring c of a pre-foam is defined in the same way as for foams. For each coloring c , surfaces $F_1(c)$ and $F_2(c)$ inherit orientations from the facets of F they contain. Surface $F_{12}(c)$ is orientable as well, say with orientation matching that of thin facets of $F_{12}(c)$ colored 1 and opposite to that of thin facets colored 2.

Orientation requirements for facets ensure that each connected component of the thin surface F_{12} of a pre-foam F will admit two checkerboard colorings, so that a pre-foam F will admit 2^k colorings, where k is the number of connected components of F .

Given a coloring c of F , the preferred thin facet at a singular circle u allows to label the circle *positive* or *negative*, as in Figure 4.13. Namely, if the preferred facet is colored 1, the circle is *positive*. If the preferred facet is colored 2, the circle is *negative*.

Define $\theta^+(c) = \theta_{12}^+(c)$ as the number of positive singular circles for the coloring c .

Thus, in a pre-foam F , each singular circle u comes with both an orientation (induced from the orientation of attached facets and, vice versa, determining them) and a choice of preferred thin facet (normal direction to the thin surface F_{12}) along u . The evaluation of F , though, will only depend on the choice of preferred facet at each singular circle, not on its orientation.

Unlike the foam case, in a $GL(2)$ pre-foam we can reverse the thin normal direction (reverse the choice of preferred thin facet) at any subset of its singular circles without making any other changes, such as reversing orientations of facets or singular circles, changing the embedding into \mathbb{R}^3 , etc. In a foam, the analogous operation of reversing the cyclic order of facets at a single circle via a simple modification of the embedding is possible only sometimes, see Figure 4.49 for an example.

Recall the chain of inclusions of rings $R \subset \tilde{R} \subset R' \subset R''$ defined in formulas (4.6)-(4.10) and (4.20).

Now, to a coloring c of a pre-foam F we assign an element $\langle F, c \rangle \in R''$ using the formula (4.4). Furthermore, define $\langle F \rangle$ via the formula (4.5).

PROPOSITION 4.17. *Evaluation $\langle F \rangle$ of any $GL(2)$ prefoam F belongs to the subring $\mathbf{k}[[E_1, E_2]]$ of R'' .*

Proof: Our proof of this result for foams, Theorem 4.1, extends to prefoams without change. \square

PROPOSITION 4.18. *Evaluation $\langle F \rangle$ of any $GL(2)$ prefoam F belongs to the subring R of $\tilde{R} = \mathbf{k}[[E_1, E_2]]$.*

Proof: Evaluations of surfaces and theta-foams, with dots, in Section 4.3 depend only on the pre-foam structure, not on an embedding in \mathbb{R}^3 . Skein relations described in Section 4.4 extend, with suitable care, to pre-foams. In Figure 4.41 relation, a pre-foam on the LHS induces pre-foam structures on terms on the right, with orientations of facets in the RHS coming from those of the LHS. With this convention, Figure 4.41 relation holds for pre-foams, where in the pre-foam F on the LHS one also remembers the cyclic order of the facets

Relations in Figures 4.44, 4.45 extend likewise. In Figure 4.47 choice of orientations of all foams (respectively, pre-foams) is encoded in the orientation of the singular circle on the RHS (equivalently, of the cyclic order of the 3 facets at the circle).

Analogue of Proposition 4.9 for pre-foams is that $\langle F' \rangle = (-1)^k \langle F \rangle$, where F' is obtained from F by reversing the cyclic order of facets at some k singular circles of F .

Figure 4.410 relation obviously extends to pre-foams. In the double facet neck-cutting relation in Figure 4.411 relation pre-foam F_1 on the right induces an orientation on the pre-foam F on the left. With this convention, Figure 4.411 relation extends to pre-foams. Dot migration relations in Figures 4.412 and 4.413 as well as the tube-cutting relation in Figure 4.414 extend to pre-foams.

Modification $m(\gamma, F)$ in Figure 4.418 can be done to a pre-foam F , assuming compatible orientations and cyclic orders along the two singular edges of F . Proposition 4.14 will hold for pre-foams as well, again assuming compatibility of the orientations and cyclic orders along the three singular edges shown in Figure 4.420.

Starting with a pre-foam F , look at the thin surface F_{12} . It may have several connected components, some of which are connected in F by double facets. Applying the double neck-cutting relation in Figure 4.411, using multiplicativity of $\langle F \rangle$ on the disjoint union of pre-foams, and the evaluation of closed double surfaces (Examples 4, 5 in Section 4.3), we can reduce the evaluation to the case when F_{12} is connected and each double facet is a disk. Applying the singular neck-cutting relation in Figure 4.41 along each singular circle of F , the evaluation reduces to that of a closed thin surface, possibly with dots, see Examples 1-3 in Section 4.3. All coefficients in the skein relations and in the evaluation of closed surfaces belong to the ring R , implying the proposition. \square

The proposition implies the next result.

PROPOSITION 4.19. *Evaluation $\langle F \rangle$ of any closed foam F coincides with the evaluation of the associated pre-foam. In particular, it belongs to the subring R of $\tilde{R} = \mathbf{k}[E_1, E_2]$.*

Proof: Foam F lives in \mathbb{R}^3 , but to evaluate it using the formulas (4.4) and (4.5) we can pass to the associated pre-foam and evaluate it instead. \square

Consequently, evaluations of all closed foams belong to the subring R of \tilde{R} . It can then be chosen as the ground ring of the theory instead of \tilde{R} , in the $GL(2)$ case.

4.6. $GL(2)$ webs, their state spaces, and direct sum decompositions.

We define $GL(2)$ closed webs Γ as generic intersections of $GL(2)$ foams with planes \mathbb{R}^2 in \mathbb{R}^3 . A $GL(2)$ web Γ is a plane trivalent oriented graph with *thin* and *thick* (or *double*) edges and vertices as in Figure 4.61.

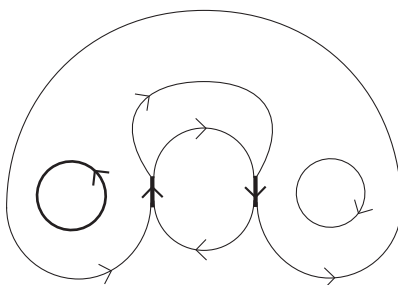

FIGURE 4.61. A $GL(2)$ web Γ with two thick edges, four thin edges, one thin and one thick circle.

Vertices of $GL(2)$ foams may be of two types. In one type, a pair of oriented thin edges flows into the vertex and a double edge flows out. In the other type, a double edge flows in and a pair of oriented thin edges flows out of the vertex. The web in Figure 4.61 has two vertices of each type.

Single and double closed loops are allowed, as well as the empty web. The union of thin edges of Γ is called the *thin one-manifold* of Γ , or the *thin cycles*

of Γ and denoted $\Gamma_{(1)}$. For Γ in Figure 4.61, the thin one-manifold $\Gamma_{(1)}$ has three connected components.

One defines $GL(2)$ foams with boundary given by a $GL(2)$ web Γ in the usual way. We use Figure 4.12 as the convention for the induced orientation of the web that is the boundary of a $GL(2)$ foam. Note that $GL(2)$ foams F in $\mathbb{R}^2 \times [0, 1]$ with the boundary $(-\Gamma_0) \sqcup \Gamma_1$, where $\Gamma_i = F \cap (\mathbb{R}^2 \times \{i\})$, $i = 0, 1$, may be viewed as cobordisms between Γ_0 and Γ_1 .

Define Foam_2 as the category where objects are $GL(2)$ webs Γ and morphisms from Γ_0 to Γ_1 are isotopy classes (rel boundary) of $GL(2)$ foams with the boundary $(-\Gamma_0) \sqcup \Gamma_1$. Composition is the concatenation of foams.

Define the degree of a foam F , not necessarily closed, as

$$(4.33) \quad \deg(F) = -\chi(F_{12}) + 2|d(F)|,$$

where $d(F)$ is the number of dots of F . Thin surface F_{12} of F is well-defined for foams with boundary. The boundary of F_{12} is the union of thin circles on the boundary of F .

For closed foams F , $\deg(F)$ equals the degree of $\langle F \rangle$, viewed as a homogeneous element of either \tilde{R} or its subring R . Degree of a foam is additive under composition of foams.

We define the state space $\langle \Gamma \rangle$ of a $GL(2)$ web Γ using the universal construction as in [BHMV, Kh2].

First, let $\text{Fr}(\Gamma)$ be the free graded R -module with a basis $\{[F]\}_F$, over all foams F from the empty web to Γ . The degree of the generator $[F]$ is defined to be $\deg(F)$. Define a bilinear form on $\text{Fr}(\Gamma)$ by

$$(4.34) \quad ([F], [G]) = \langle w(G)F \rangle,$$

where $w(G)$ is the reflection of G in the horizontal plane together with the orientation reversal of all facets of G to make F and $w(G)$ composable along F . The foam $w(G)F$ is closed and can be evaluated to an element of R . Given a closed foam H , reflecting it about a plane into a foam H' may add sign to the evaluation, $\langle H' \rangle = (-1)^k \langle H \rangle$, where k is the number of singular circles of H . To get rid of the sign, reverse orientation of all facets of H' to get a foam $w(H)$ with $\langle w(H) \rangle = \langle H \rangle$. A similar argument works for non-closed foams. Consequently, the bilinear form (4.34) is symmetric.

Define the state space $\langle \Gamma \rangle$ as the quotient of $\text{Fr}(\Gamma)$ by the kernel of the bilinear form $(,)$. The state space $\langle \Gamma \rangle$ is a graded R -module, via the degree formula (4.33). As usual in the universal construction, a foam F with boundary $(-\Gamma_0) \sqcup \Gamma_1$ induces a homogeneous R -module map

$$\langle F \rangle : \langle \Gamma_0 \rangle \longrightarrow \langle \Gamma_1 \rangle$$

of degree $\deg(F)$ taking an element $\langle G \rangle \in \langle \Gamma_0 \rangle$ associated to a foam G with boundary Γ_0 to the element $\langle FG \rangle$ associated to the foam FG with boundary Γ_1 . These maps assemble into a functor from the category of $GL(2)$ foams to the category of graded R -modules and homogeneous R -module maps. The results below imply that the functor is monoidal.

The state space of the empty web is naturally isomorphic to the free rank one module over R with a generator in degree zero, $\langle \emptyset \rangle \cong R$.

Let Γ' denote the web Γ with an innermost thin circle (with one of the two orientations) added in a region of Γ . Thus, Γ' depends on the choice of a region of Γ and the orientation of the circle.

PROPOSITION 4.20. *There are natural isomorphisms of graded R -modules*

$$\langle \Gamma' \rangle \cong \langle \Gamma \rangle \{1\} \oplus \langle \Gamma \rangle \{-1\},$$

for Γ, Γ' as above and $\{m\}$ the grading shift up by m .

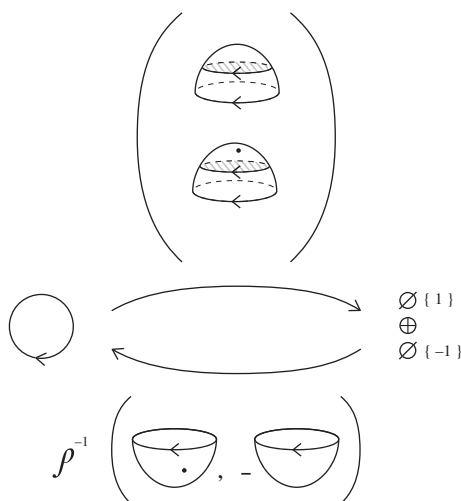

FIGURE 4.62. Direct sum decomposition for an innermost thin circle with the clockwise orientation. For the opposite orientation of the circle, reverse the orientation of the singular circle as well and add an overall minus sign to one of the two maps.

Proof: Foam cobordisms that deliver this direct sum decomposition are shown in Figure 4.62. The composition of the maps in either order is the identity, as follows from Θ -foam evaluations in section 4.3 and neck-cutting relation in Figure 4.47. \square

PROPOSITION 4.21. *The saddle cobordism in a thick facet induces a grading-preserving isomorphism between the state spaces of its two boundary webs, see Figure 4.63. The inverse isomorphism is given by the adjoint saddle cobordism scaled by ρ^{-1} .*

Proof: This follows from the thick neck-cutting relation in Figure 4.411. \square

PROPOSITION 4.22. *Let Γ be a web and Γ' be Γ with added innermost thick circle. There is a canonical degree zero isomorphism of state spaces*

$$\langle \Gamma' \rangle \cong \langle \Gamma \rangle$$

given by the cobordisms in Figure 4.64.

PROPOSITION 4.23. *Let web Γ have a thin edge and denote by Γ' the web Γ with an attached double edge along the thin edge. The state spaces of Γ and Γ' are naturally isomorphic as graded R -modules via the maps given in Figure 4.65.*

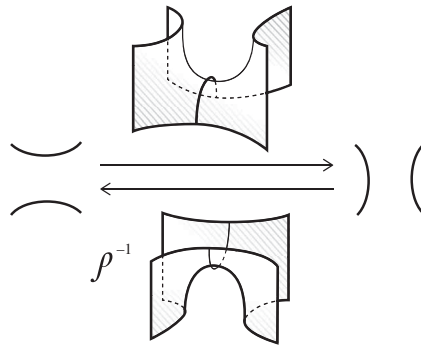

FIGURE 4.63. Saddle isomorphism on a double facet. Double edges on the left and right must carry compatible orientation (that is, extendable to the orientation of the surface).

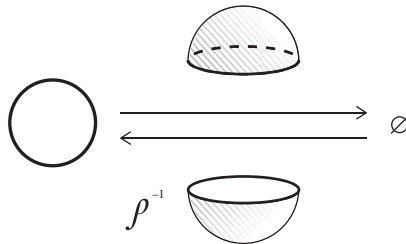

FIGURE 4.64. An isomorphism between a diagram with an innermost double circle and the diagram without it, via double cup and cap cobordisms.

Proof: This follows from relations in Figures 4.424 and 4.45. \square

THEOREM 4.24. $\langle \Gamma \rangle$ is a free graded R -module of graded rank $[2]^m$, where m is the number of components (circles) of the thin one-manifold $\Gamma_{(1)}$ and $[2] = q + q^{-1}$.

Proof: This can be proved by induction on m . An innermost thin or double circle of Γ , see Figure 4.66, can be removed using isomorphisms in Figures 4.62 and 4.64, respectively.

Now look at $\Gamma_{(1)}$ and choose an innermost circle α in it. We distinguish between innermost circles of Γ and those of $\Gamma_{(1)}$. The latter correspond to thin circles in Γ which may contain vertices and thus have attached double edges. α bounds a disk D^2 in \mathbb{R}^2 . Double edges emanating out of α split into those inside and outside of D^2 . Repeatedly applying the double saddle isomorphism in Figure 4.63, we can reduce to the case when each of these double edges has both endpoints on α . Going along α one encounters $2n$ vertices (an even number due to orientation reversal along α at each vertex). If at two consecutive vertices double edges both point in or out of D^2 , one can apply an isomorphism in Figure 4.63 followed by an isomorphism in Figure 4.65 to reduce from $2n$ to $2n - 2$ vertices along α . A configuration where such a pair of vertices does not exist is impossible for $n > 0$, for then the n ends

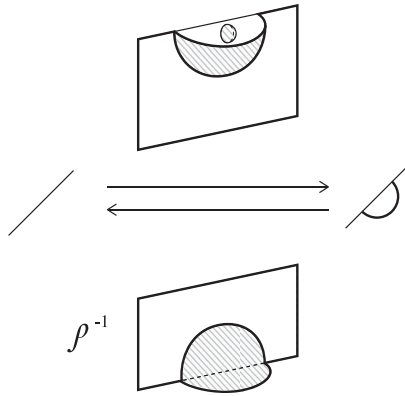

FIGURE 4.65. Mutually-inverse isomorphisms between a thin edge and a thin edge with an attached double edge.



FIGURE 4.66. Thin and double innermost circles.

of double edges pointing into D^2 from α would all have the same orientations and there would be no room for the other n ends of these edges to land. This concludes the inductive argument. \square

COROLLARY 4.25. *Associating the state space $\langle \Gamma \rangle$ to a $GL(2)$ web Γ and the map $\langle F \rangle$ of state spaces to a foam F with boundary is a monoidal functor from the category of $GL(2)$ foams to the category of free graded R -modules of finite rank.*

5. Reidemeister moves invariance and link homology

With the state spaces $\langle \Gamma \rangle$ of $GL(2)$ webs Γ defined, we can associate homology groups to a generic projection D of an oriented link $L \subset \mathbb{R}^3$, as follows. Let D has n crossings. We resolve each crossing into two resolutions, 0- and 1-resolutions, as in Figure 5.01.

One of the resolutions consists of two disjoint thin edges, the other contains a double edge and four adjoint thin edges. All the edges are oriented. Choose a total order on crossings of D . Doing this procedure over all crossings results in 2^n resolutions of D into $GL(2)$ webs $D(\bar{\mu})$, for $\bar{\mu} = (\mu_1, \dots, \mu_n)$, with $\mu_i \in \{0, 1\}$. In a web $D(\bar{\mu})$ the i -th crossing is resolved according to μ_i .

To a crossing now associate a complex of two webs with boundaries and the differential induced by the “singular saddle” cobordism between them, see Figure 5.02 which sets us the terms in the complex, and Figure 5.03 which depicts “singular saddle” foams inducing the differential. These complexes make sense whenever the two webs are closed on the outside into two closed $GL(2)$ webs. Grading shifts

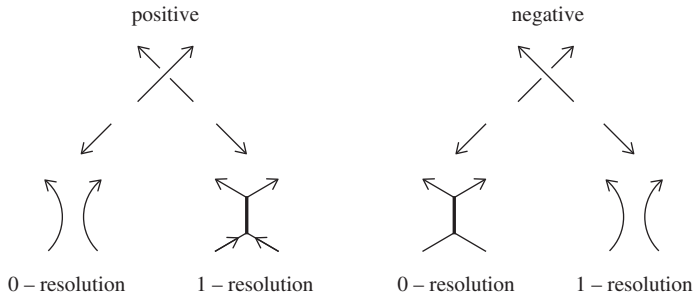

FIGURE 5.01. Resolutions of positive and negative crossings.

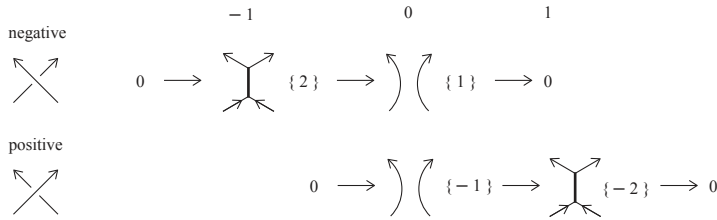

FIGURE 5.02. Complexes associated to positive and negative crossings. Numbers at the top show homological gradings of the terms. Resolution into two edges is always in homological degree 0.

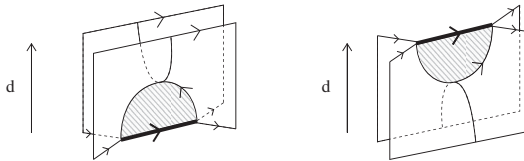

FIGURE 5.03. Foams that induce the differential in the complexes for positive and negative crossings. Upward-pointing arrows next to the foams indicate the 'direction' of the differential.

are inserted to make the map induced by the “singular saddle” cobordism grading-preserving (and, later, to have full invariance under the Reidemeister I move, rather than an invariance up to an overall grading shift).

In this way, one can form a commutative n -dimensional cube which has the graded R -module $\langle D(\bar{\mu}) \rangle$ in its vertex labelled by the sequence $\bar{\mu}$ and maps induced by “singular saddle” foams associated to oriented edges of the cube. The maps commute for every square of the cube.

This setup with “singular saddle” cobordisms goes back to Blanchet [B], and is also visible in the earlier papers of Clark-Morrison-Walker [CMW] and Caprau [Ca1],

Ca2], where the double facet is not there, but its boundary, a singular edge along the foam, together with a choice of normal direction, is present.

The commuting cube of graded R -modules $\langle \Gamma(\bar{\mu}) \rangle$ and grading-preserving homomorphisms between them collapses, in the standard way upon adding minus signs, to a complex of graded R -modules with a degree-preserving differential. This complex starts in the homological degree $-$ minus the number of negative crossings of D and ends in the homological degree which is the number of positive crossings of D .

Denote this complex by $F(D)$.

THEOREM 5.1. *For two diagrams D_1 and D_2 of an oriented link L , complexes $F(D_1)$ and $F(D_2)$ are chain homotopy equivalent as complexes of graded R -modules.*

Proof: Consider the Reidemeister move R1, undoing a positive curl in Figure 5.04.

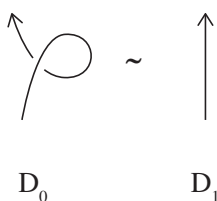

FIGURE 5.04. Reidemeister move R1, for a positive twist.

PROPOSITION 5.2. *The following relations hold on maps f_0, g_0, h and d in Figures 5.05, 5.06:*

$$\begin{aligned}
 (5.1) \quad & dh = \text{id}, \\
 (5.2) \quad & df_0 = 0, \\
 (5.3) \quad & g_0 f_0 = \text{id}_{F(D_1)}, \\
 (5.4) \quad & \text{id} = f_0 g_0 + hd.
 \end{aligned}$$

The map id in the first equation is the identity of the complex $F(D_0(1))$, associated to the diagram in the top right corner of Figure 5.05, while id in the last equation is the identity of the complex $F(D_0(0))$ associated to the diagram the top left corner of the figure.

Proof: is a direct computation using skein relations derived in Section 4.4. This proof is very similar to the proof of the invariance under the Reidemeister move in [MSV], that does it in the non-equivariant $GL(N)$ case, in particular see Figure 8 there. \square

COROLLARY 5.3. *Complexes $F(D_0)$ and $F(D_1)$, for diagrams in Figure 5.04, are chain homotopy equivalent as complexes of graded R -modules.*

PROPOSITION 5.4. *For each pair of the diagrams D_0, D_1 in Figure 5.07, which shows Reidemeister moves R2 and R3, complexes $F(D_0)$ and $F(D_1)$ are chain homotopy equivalent as complexes of graded R -modules.*

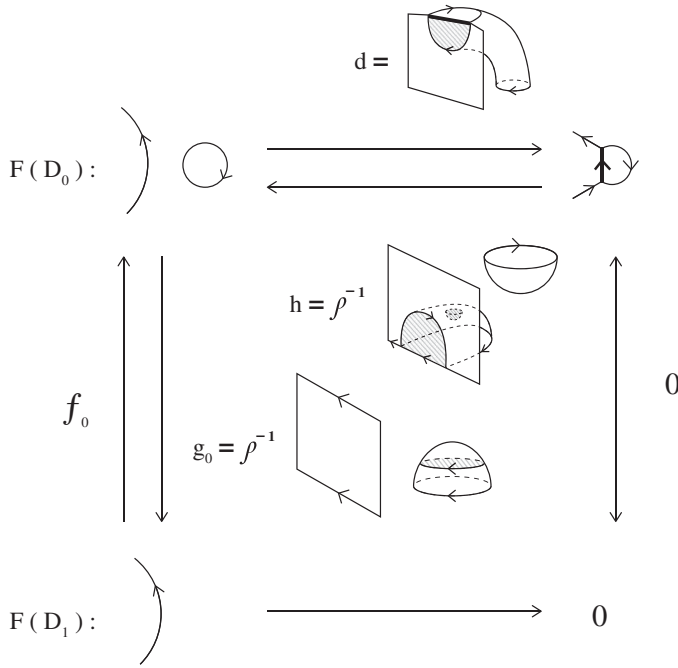

FIGURE 5.05. Top row, together with the right-pointing arrow d , encodes the complex $F(D_0)$. Top left-pointing arrow h is a self-homotopy of $F(D_0)$. Down and up arrows h_0 and g_0 are maps of complexes $F(D_0)$ and $F(D_1)$. Map f_0 is given in the next figure.

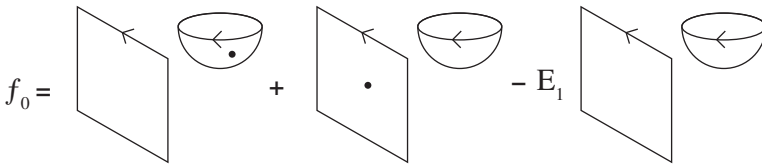

FIGURE 5.06. Map $f_0 : F(D_1) \rightarrow F(D_0)$ of complexes.

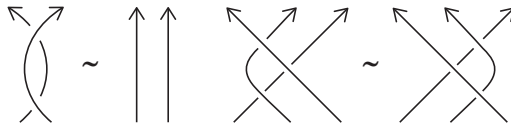

FIGURE 5.07. Reidemeister moves R2 and R3.

Proof: For the Reidemeister R2 move, relation (4.416) used in the direct sum of decomposition of a web Γ_1 with a digon facet into the sum of two copies of the simpler web Γ_0 is no different from the corresponding decomposition in the usual

$SL(N)$ graphical calculus, for an arbitrary N (see [Kh2, Proposition 8] for the analogous decomposition in the non-equivariant $SL(3)$ case). As one of the relations for this decomposition, the relation of removing a bubble on a double facet with at most one dot on one of the two thin facets is identical with the corresponding relation in the usual $SL(N)$ foam calculus, whether for the standard calculus or the equivariant one. Bubble removal relation follows from the combination of theta foam evaluation in Example 6 in Section 4.3 for $n_1, n_2 \leq 1$ and Proposition 4.11. For essentially the same relations in the $SL(3)$ case see, for instance, the top two relations in [Kh2, Figure 18].

For this reason, the usual proof of the Reidemester R2 relation, when both strands are oriented in the same direction, as in Figure 5.07 left, repeats without any changes in our case, see for instance [Kh2, Section 5.2], [MSV, Theorem 7.1], and many other sources.

Reideimeister move R2 for the oppositely oriented strands can be shown by simplifying the complex for the two crossings by splitting off contractible summands using the maps in Figure 5.05. The remaining complex has a single term that differs from two parallel lines by a pair of double lines connecting them. The standard cobordisms between these two diagrams need to be twisted by a pair of double caps on two thin facets to make them the inverses of each other (a double cap is shown, for instance, at the top of Figure 4.65 and in Figure 4.422). We leave the details to an interested reader.

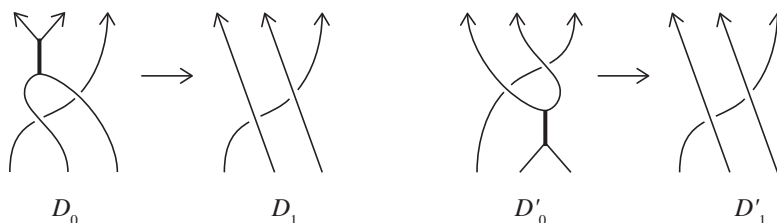

FIGURE 5.08. Two partial resolutions of each of D and D' . Note that D_1 and D'_1 are identical diagrams.

Consider the Reidemeister R3 move in Figure 5.07. Denote by D and D' the diagrams on the left and right of this move.

We start by resolving a single crossing in each of D and D' , see Figure 5.08. Complexes $C(D)$ and $C(D')$ are isomorphic to cones of maps $C(D_0) \rightarrow C(D_1)$ and $C(D'_0) \rightarrow C(D'_1)$ built out of foams between complete resolutions of these diagrams.

Tangle diagrams D_1 and D'_1 are canonically isomorphic, and their resolutions result in the total complex of the square shown in Figure 5.09 with the differential coming from the four foams associated to the arrows of the diagram, with each foam a standard singular saddle in the appropriate position.

Consider now the diagram D_0 and its resolution in Figure 5.010. Maps ψ_k , $k = 1, \dots, 4$ are homomorphisms between state spaces of web induced by appropriate foams (singular saddle foams). Summing over all possible resolutions

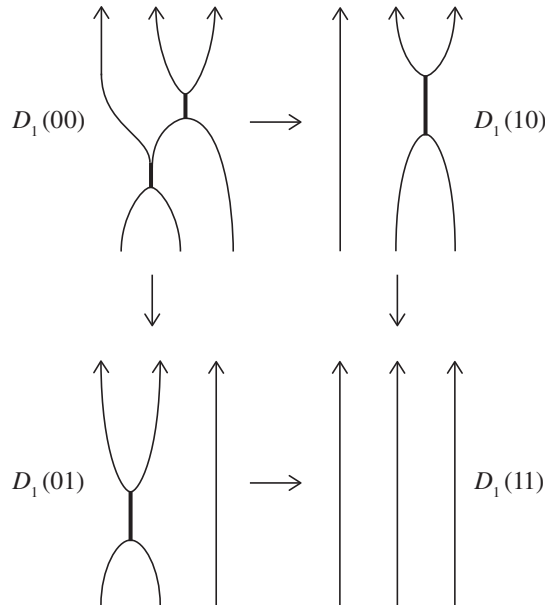

FIGURE 5.09. Resolution of the diagram $D_1 \cong D'_1$.

of crossings of D_0 not shown in the diagram gives homomorphisms, also denoted ψ_1, \dots, ψ_4 , of corresponding complexes.

The four terms $C(D_0(k\ell))$, $k, \ell \in \{0, 1\}$, will also map to the corresponding four terms $C(D_1(k\ell))$ in $C(D_1)$ in Figure 5.09 to constitute a 3-dimensional cube diagram (not shown).

The complex $C(D_0(00))$ of the diagram in the upper left of Figure 5.010 is isomorphic (and not just homotopy equivalent) to the complex $C(D_2)$ of the diagram D_2 shown in Figure 5.011 left.

Foam F_0 going from $D_0(00)$ to D_2 'straightens out' the long thin arc u_0 of $D_0(00)$ by canceling in pairs the four vertices on this arc where double edges meet u_0 . Arc u_0 becomes the rightmost arc u_2 of D_2 . Seam edges that cancel the four vertices in pairs are shown in Figure 5.012 as two arcs in the upper half of the diagram. The upper half shows the thin facet of F_0 where singular vertices along u_0 are cancelled in pairs. These cancellations are done via singular arcs, shown in Figure 5.012 top, along which double facets are attached to the thin facet.

Foam F_1 goes back from D_2 to $D_0(00)$ and is given by reflecting F_0 in the horizontal plane. The thin facet of F_1 is shown as the lower half of Figure 5.012. Semicircles depict singular edges along the thin facet.

Denote the maps F_0, F_1 induce on state spaces and on complexes built out of the state spaces of all resolutions of $D_0(00)$ and D_2 by

$$(5.5) \quad \tau_0 : C(D_0(00)) \longrightarrow C(D_2), \quad \tau_1 : C(D_2) \longrightarrow C(D_0(00)).$$

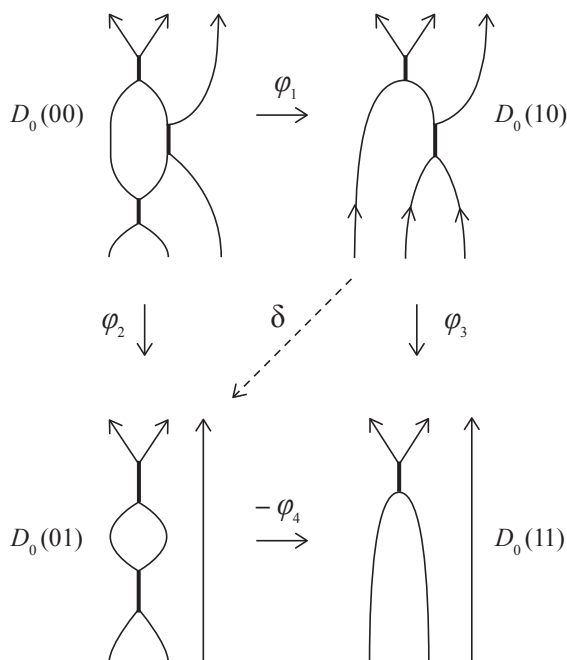

FIGURE 5.010. Resolution of the diagram D_0 .

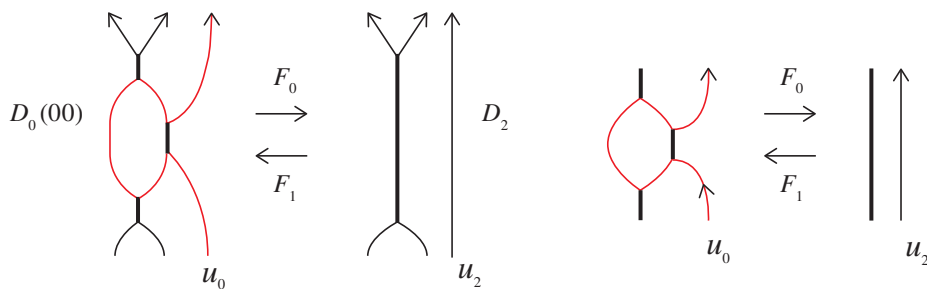

FIGURE 5.011. Diagrams $D_0(00)$ and D_2 have isomorphic state spaces for any resolution of these diagrams. Complexes $C(D_0(00))$ and $C(D_2)$, with the differentials induced by various foams between their resolutions, are canonically isomorphic, $C(D_0(00)) \cong C(D_2)$ in the abelian category of complexes (before factoring by homotopies).

We know that both τ_0 and τ_1 are isomorphisms of the state spaces and corresponding complexes, since annihilating a digon facet with a thick edge is an isomorphism, see Proposition 4.23.

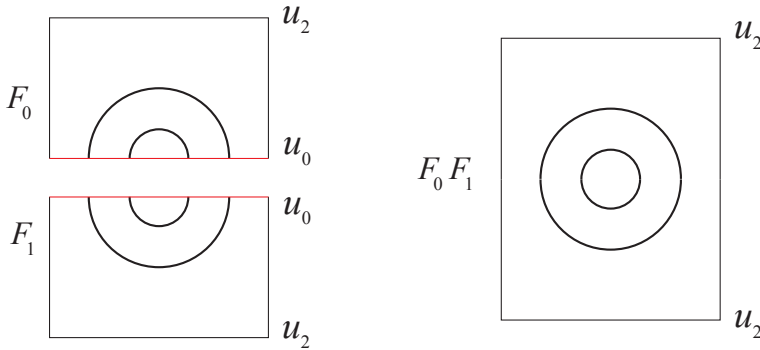

FIGURE 5.012. Flattened thin facets of F_0 and F_1 containing arcs u_0, u_2 . Composition $F_0 F_1$ contains thin surface S (shown on the right) given by gluing the two thin surfaces along the common arc u_0 . This surface has two singular circles where double facets attach.

More precisely, $\tau_0 \tau_1 = -\rho^{-1} \text{Id}$. Indeed, the composition $\tau_0 \tau_1$ is an endomorphism of the state space $\langle \Gamma \rangle$ for each web resolution Γ of D_2 and the induced endomorphism of the complex $C(D_2)$. The map $\tau_0 \tau_1 : \langle \Gamma \rangle \rightarrow \langle \Gamma \rangle$ transforms arc u_2 of the diagram D_2 to the arc u_0 of $D_0(00)$ and back, via the composition of foams $F_0 F_1$.

Consider the thin surface S bounded by u_2 at the top and bottom of the cobordism $F_0 F_1$. It can be visualized by gluing the two thin surfaces for F_0 and F_1 shown in Figure 5.012 along the common arc u_0 , shown in red. Surface S contains two nested singular circles, where double facets of $F_0 F_1$ meet S . Double facets at these two circles attach to S from opposite sides, as one can glean from Figure 5.011. This corresponds to having two double edges attached to arc u_0 on one side and the other double edge attached to u_0 on the other side of the plane, at both endpoints, see the leftmost diagram in Figure 5.011.

Apply Proposition 4.11 at each of these attached double facets to simplify the non-trivial part of the foam $F_0 F_1$ to the surface S with two double disks attached to it from the opposite sides along the two singular circles, with an additional factor ρ^{-2} . We then apply Proposition 4.8 to flip one of the disks to the opposite side, gaining a minus sign, and then use Proposition 4.11 to reduce to the identity foam times $-\rho^{-1}$.

Consequently, maps τ_0 and $-\rho \tau_1$ are mutually-inverse isomorphisms.

Note that diagrams $D_0(11)$ and D_2 are isotopic and their complexes are canonically isomorphic. Complex $C(D_0(01))$ decomposes into direct sum of two copies of $D_0(11)$ in the usual way. The composition $\psi_2 \tau_1 : C(D_2) \rightarrow C(D_0(01))$ is a split inclusion into one of these copies. Since τ_1 is an isomorphism, this composition allows to split off contractible summand

$$0 \rightarrow C(D_0(00)) \xrightarrow{\cong} \text{im}(\psi_2) \rightarrow 0$$

from the total complex of D_0 , also see Figure 5.010. The map ψ_4 induces an isomorphism from the complementary direct summand of $C(D_0(01))$, also isomorphic to $C(D_2)$, to $C(D_0(11))$, allowing to split the second contractible summand from $C(D_0)$. After removing these contractible summands, the entire complex $C(D_0)$ in Figure 5.010 is downsized to $C(D_0(10))$. The inclusion $C(D_0(10)) \subset C(D_0)$ realizing this chain homotopy equivalence is given in coordinates by (id, δ) , see Figure 5.010 with δ the diagonal map induced by the simplest cobordism from $D_0(10)$ to $D_0(01)$, with the property $\psi_3 = \psi_4\delta$.

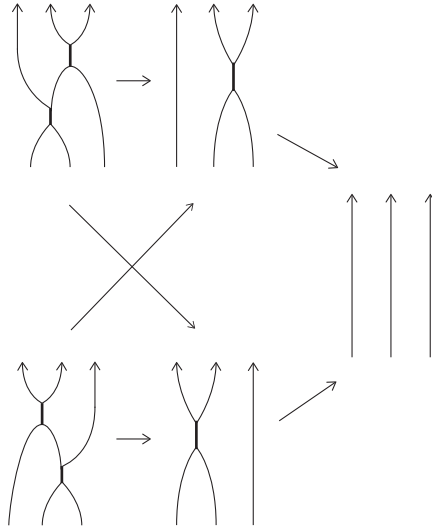

FIGURE 5.013. Common reduction of $C(D)$ and $C(D')$.

Reducing the map of complexes $C(D_0) \rightarrow C(D_1)$ to the map $C(D_0(10)) \rightarrow C(D_1)$ via the above inclusion of complexes results in the complex shown in Figure 5.013, with all arrows given by maps induced by the elementary foams between these webs. Signs need to be added to make each square anticommute, but the isomorphism class of the complex does not depend on the distribution of signs. This complex has an obvious symmetry given by reflecting all diagrams and foams about the vertical axis (or plane, in case of foams) and permuting top and bottom terms in the complex.

The cone of the map $C(D'_0) \rightarrow C(D'_1)$ in Figure 5.08 right reduces to the isomorphic complex, by removing contractible summands of $C(D'_0)$ in the same fashion as for $C(D_0)$. \square

This completes the proof of Theorem 5.1. \square

Our proofs of the Reidemeister R2 and R3 relations, for upwards orientations and in $N = 2$ case, are essentially identical to those in the usual equivariant case, when $p_{ij} = 1$. This observation mirrors our earlier Theorem 3.17 and Remark 3.18 that our deformation does not change the nilHecke algebra relation. This makes it likely that our $p(x, y)$ deformation does not modify the Soergel category and that the Soergel category will act in the deformed situation as well, with the proofs

of Reidemeister R2 and R3 moves for upward orientations identical to that in the $p(x, y) = 1$ case. Then $p(x, y)$ deformation would only modify the first Reidemeister move and Reidemeister moves R2 and R3 for non-braid orientations of strands. This expectation mirrors our observation that $p(x, y)$ may only contribute to the deformation of the Frobenius structure, not of multiplication. In the $N = 2$ case, similar deformations can be hidden at the level of link homology, see [V, Kh4].

Acknowledgments. M.K. was partially supported by NSF grants DMS-1664240 and DMS-1807425 while working on this paper. The authors are grateful to Yakov Kononov, Louis-Hadrien Robert and Lev Rozansky for valuable discussions and would like to thank Elizaveta Babaeva¹ for help with producing figures for the paper. The authors would also like to thank Joshua Sussan and the anonymous referee for many valuable corrections to the earlier version of the paper.

References

- [Ba] J. C. Baez, *An introduction to spin foam models of BF theory and quantum gravity*, Geometry and quantum physics (Schladming, 1999), Lecture Notes in Phys., vol. 543, Springer, Berlin, 2000, pp. 25–93, DOI 10.1007/3-540-46552-9_2. MR1770708
- [BE] P. Bressler and S. Evens, *The Schubert calculus, braid relations, and generalized cohomology*, Trans. Amer. Math. Soc. **317** (1990), no. 2, 799–811, DOI 10.2307/2001488. MR968883
- [BN] D. Bar-Natan, *On Khovanov’s categorification of the Jones polynomial*, Algebr. Geom. Topol. **2** (2002), 337–370, DOI 10.2140/agt.2002.2.337. MR1917056
- [BHPW] A. Beliakova, M. Hogancamp, K. Putyra, and S. Wehrli, *On the functoriality of $sl(2)$ tangle homology*, Algebraic & Geometric Topology **23** (2023) 1303–1361, DOI: 10.2140/agt.2023.23.1303.
- [B] C. Blanchet, *An oriented model for Khovanov homology*, J. Knot Theory Ramifications **19** (2010), no. 2, 291–312, DOI 10.1142/S0218216510007863. MR2647055
- [BHMV] C. Blanchet, N. Habegger, G. Masbaum, and P. Vogel, *Topological quantum field theories derived from the Kauffman bracket*, Topology **34** (1995), no. 4, 883–927, DOI 10.1016/0040-9383(94)00051-4. MR1362791
- [Bo] D. Boozer, (2021) *Computer Bounds for Kronheimer-Mrowka Foam Evaluation*, Experimental Mathematics, DOI: 10.1080/10586458.2021.1982078
- [Ca1] C. L. Caprau, *$sl(2)$ tangle homology with a parameter and singular cobordisms*, Algebr. Geom. Topol. **8** (2008), no. 2, 729–756, DOI 10.2140/agt.2008.8.729. MR2443094
- [Ca2] C. L. Caprau, *The universal $sl(2)$ cohomology via webs and foams*, Topology Appl. **156** (2009), no. 9, 1684–1702, DOI 10.1016/j.topol.2009.02.001. MR2521705
- [CMW] D. Clark, S. Morrison, and K. Walker, *Fixing the functoriality of Khovanov homology*, Geom. Topol. **13** (2009), no. 3, 1499–1582, DOI 10.2140/gt.2009.13.1499. MR2496052
- [C] B. Cooper, *Deformations of nilHecke algebras*, Acta Math. Vietnam. **39** (2014), no. 4, 515–527, DOI 10.1007/s40306-014-0085-9. MR3292580
- [ETW] M. Ehrig, D. Tubbenhauer, and P. Wedrich, *Functoriality of colored link homologies*, Proc. Lond. Math. Soc. (3) **117** (2018), no. 5, 996–1040, DOI 10.1112/plms.12154. MR3877770
- [EST1] M. Ehrig, C. Stroppel and D. Tubbenhauer, *Generic gl_2 -foams, webs, and arc algebras*, arXiv:1601.08010.
- [EST2] M. Ehrig, C. Stroppel, and D. Tubbenhauer, *The Blanchet-Khovanov algebras*, Categorification and higher representation theory, Contemp. Math., vol. 683, Amer. Math. Soc., Providence, RI, 2017, pp. 183–226, DOI 10.1090/conm/683. MR3611714
- [Ha] M. Hazewinkel, *Formal groups and applications*, Pure and Applied Mathematics, vol. 78, Academic Press, Inc. [Harcourt Brace Jovanovich, Publishers], New York-London, 1978. MR506881

¹Elizaveta Babaeva, <https://www.behance.net/lizababaiva>

- [HBJ] F. Hirzebruch, T. Berger, and R. Jung, *Manifolds and modular forms*, Aspects of Mathematics, E20, Friedr. Vieweg & Sohn, Braunschweig, 1992, DOI 10.1007/978-3-663-14045-0. MR1189136
- [HMSZ] A. Hoffnung, J. Malagón-López, A. Savage, and K. Zainoulline, *Formal Hecke algebras and algebraic oriented cohomology theories*, *Selecta Math. (N.S.)* **20** (2014), no. 4, 1213–1245, DOI 10.1007/s00029-013-0132-8. MR3273635
- [HKK] P. Hu, D. Kriz, and I. Kriz, *Field theories, stable homotopy theory, and Khovanov homology*, *Topology Proc.* **48** (2016), 327–360. MR3465966
- [J] M. Jacobsson, *An invariant of link cobordisms from Khovanov homology*, *Algebr. Geom. Topol.* **4** (2004), 1211–1251, DOI 10.2140/agt.2004.4.1211. MR2113903
- [Kh1] M. Khovanov, *A categorification of the Jones polynomial*, *Duke Math. J.* **101** (2000), no. 3, 359–426, DOI 10.1215/S0012-7094-00-10131-7. MR1740682
- [Kh2] M. Khovanov, *$sl(3)$ link homology*, *Algebr. Geom. Topol.* **4** (2004), 1045–1081, DOI 10.2140/agt.2004.4.1045. MR2100691
- [Kh3] M. Khovanov, *An invariant of tangle cobordisms*, *Trans. Amer. Math. Soc.* **358** (2006), no. 1, 315–327, DOI 10.1090/S0002-9947-05-03665-2. MR2171235
- [Kh4] M. Khovanov, *Link homology and Frobenius extensions*, *Fund. Math.* **190** (2006), 179–190, DOI 10.4064/fm190-0-6. MR2232858
- [KR] M. Khovanov and L.-H. Robert, *Foam evaluation and Kronheimer-Mrowka theories*, *Adv. Math.* **376** (2021), Paper No. 107433, 59 pp., DOI 10.1016/j.aim.2020.107433. MR4178907
- [KRW] M. Khovanov, L.-H. Robert, and E. Wagner, *In preparation*.
- [KRo1] M. Khovanov and L. Rozansky, *Matrix factorizations and link homology*, *Fund. Math.* **199** (2008), no. 1, 1–91, DOI 10.4064/fm199-1-1. MR2391017
- [KRo2] M. Khovanov and L. Rozansky, *Topological Landau-Ginzburg models on the world-sheet foam*, *Adv. Theor. Math. Phys.* **11** (2007), no. 2, 233–259. MR2322554
- [K1] N. Kitchloo, *Symmetry Breaking and Link Homologies I*, preprint, arXiv:1910.07443.
- [K2] N. Kitchloo, *Symmetry Breaking and Link Homologies II*, preprint, arXiv:1910.07444.
- [MSV] M. Mackaay, M. Stošić, and P. Vaz, *$sl(N)$ -link homology ($N \geq 4$) using foams and the Kapustin-Li formula*, *Geom. Topol.* **13** (2009), no. 2, 1075–1128, DOI 10.2140/gt.2009.13.1075. MR2491657
- [MV1] M. Mackaay and P. Vaz, *The universal sl_3 -link homology*, *Algebr. Geom. Topol.* **7** (2007), 1135–1169, DOI 10.2140/agt.2007.7.1135. MR2336253
- [MV2] M. Mackaay and P. Vaz, *The diagrammatic Soergel category and $sl(N)$ -foams, for $N \geq 4$* , *Int. J. Math. Math. Sci.*, posted on 2010, Art. ID 468968, 20, DOI 10.1155/2010/468968. MR2671770
- [MOY] H. Murakami, T. Ohtsuki, and S. Yamada, *Homfly polynomial via an invariant of colored plane graphs*, *Enseign. Math. (2)* **44** (1998), no. 3-4, 325–360. MR1659228
- [LS1] R. Lipshitz and S. Sarkar, *A Khovanov stable homotopy type*, *J. Amer. Math. Soc.* **27** (2014), no. 4, 983–1042, DOI 10.1090/S0894-0347-2014-00785-2. MR3230817
- [LS2] R. Lipshitz and S. Sarkar, *A Steenrod square on Khovanov homology*, *J. Topol.* **7** (2014), no. 3, 817–848, DOI 10.1112/jtopol/jtu005. MR3252965
- [M] J. Morava, *On the complex cobordism ring as a Fock representation*, *Homotopy theory and related topics (Kinosaki, 1988)*, *Lecture Notes in Math.*, vol. 1418, Springer, Berlin, 1990, pp. 184–204, DOI 10.1007/BFb0083703. MR1048186
- [NN1] M. Nakagawa and H. Naruse, *Universal Gysin formulas for the universal Hall-Littlewood functions*, *An alpine bouquet of algebraic topology*, *Contemp. Math.*, vol. 708, Amer. Math. Soc., [Providence], RI, 2018, pp. 201–244, DOI 10.1090/conm/708/14267. MR3807757
- [NN2] M. Nakagawa and H. Naruse, *Darondeau-Pragacz formulas in complex cobordism*, *Math. Ann.* **381** (2021), no. 1-2, 335–361, DOI 10.1007/s00208-021-02196-5. MR4322614
- [Na] H. Naruse, *Elementary proof and application of the generating functions for generalized Hall-Littlewood functions*, *J. Algebra* **516** (2018), 197–209, DOI 10.1016/j.jalgebra.2018.09.010. MR3863476
- [Nt] S. M. Natanzon, *Cyclic foam topological field theories*, *J. Geom. Phys.* **60** (2010), no. 6-8, 874–883, DOI 10.1016/j.geomphys.2010.02.004. MR2647289

- [QR] H. Queffelec and D. E. V. Rose, *The \mathfrak{sl}_n foam 2-category: a combinatorial formulation of Khovanov-Rozansky homology via categorical skew Howe duality*, Adv. Math. **302** (2016), 1251–1339, DOI 10.1016/j.aim.2016.07.027. MR3545951
- [RT] N. Yu. Reshetikhin and V. G. Turaev, *Ribbon graphs and their invariants derived from quantum groups*, Comm. Math. Phys. **127** (1990), no. 1, 1–26. MR1036112
- [RW1] L.-H. Robert and E. Wagner, *A closed formula for the evaluation of foams*, Quantum Topol. **11** (2020), no. 3, 411–487, DOI 10.4171/qt/139. MR4164001
- [RW2] L.-H. Robert and E. Wagner, *Symmetric Khovanov-Rozansky link homologies* (English, with English and French summaries), J. Éc. polytech. Math. **7** (2020), 573–651, DOI 10.5802/jep.124. MR4086581
- [RW3] L.-H. Robert and E. Wagner, *A quantum categorification of the Alexander polynomial*, Geom. Topol. **26** (2022), no. 5, 1985–2064, DOI 10.2140/gt.2022.26.1985. MR4520301
- [RWd] D. E. V. Rose and P. Wedrich, *Deformations of colored \mathfrak{sl}_N link homologies via foams*, Geom. Topol. **20** (2016), no. 6, 3431–3517, DOI 10.2140/gt.2016.20.3431. MR3590355
- [St] N. P. Strickland, *Formal schemes and formal groups*, Homotopy invariant algebraic structures (Baltimore, MD, 1998), Contemp. Math., vol. 239, Amer. Math. Soc., Providence, RI, 1999, pp. 263–352, DOI 10.1090/conm/239/03608. MR1718087
- [TT] V. Turaev and P. Turner, *Unoriented topological quantum field theory and link homology*, Algebr. Geom. Topol. **6** (2006), 1069–1093, DOI 10.2140/agt.2006.6.1069. MR2253441
- [Vz] P. Vaz, *The diagrammatic Soergel category and $\mathfrak{sl}(2)$ and $\mathfrak{sl}(3)$ foams*, Int. J. Math. Math. Sci., posted on 2010, Art. ID 612360, 23 pp., DOI 10.1155/2010/612360. MR2652384
- [V] P. Vogel, *Functoriality of Khovanov homology*, J. Knot Theory Ramifications **29** (2020), no. 4, 2050020, 66 pp., DOI 10.1142/S0218216520500200. MR4096813
- [We] B. Webster, *Knot invariants and higher representation theory*, Mem. Amer. Math. Soc. **250** (2017), no. 1191, v+141, DOI 10.1090/memo/1191. MR3709726
- [Wd] P. Wedrich, *Exponential growth of colored HOMFLY-PT homology*, Adv. Math. **353** (2019), 471–525, DOI 10.1016/j.aim.2019.06.023. MR3982970
- [W] E. Witten, *Quantum field theory and the Jones polynomial*, Comm. Math. Phys. **121** (1989), no. 3, 351–399. MR990772
- [Wu1] H. Wu, *Colored \mathfrak{sl}_N link homology via matrix factorizations*, arXiv:1110.2076.
- [Wu2] H. Wu, *Equivariant colored $\mathfrak{sl}(N)$ -homology for links*, J. Knot Theory Ramifications **21** (2012), no. 2, 1250012, 104 pp., DOI 10.1142/S0218216511009558. MR2885476
- [Y] Y. Yonezawa, *Quantum $(\mathfrak{sl}_n, \wedge V_n)$ link invariant and matrix factorizations*, Nagoya Math. J. **204** (2011), 69–123, DOI 10.1215/00277630-1431840. MR2863366

DEPARTMENT OF MATHEMATICS, COLUMBIA UNIVERSITY, NEW YORK, NEW YORK 10027
Email address: khovanov@math.columbia.edu

DEPARTMENT OF MATHEMATICS, JOHNS HOPKINS UNIVERSITY, BALTIMORE, MARYLAND 21218
Email address: nitu@math.jhu.edu