

# COMPOSITIO MATHEMATICA

## Sutured instanton homology and Heegaard diagrams

John A. Baldwin, Zhenkun Li and Fan Ye

Compositio Math. **159** (2023), 1898–1915.

[doi:10.1112/S0010437X23007303](https://doi.org/10.1112/S0010437X23007303)



FOUNDATION  
COMPOSITIO  
MATHEMATICA



LONDON  
MATHEMATICAL  
SOCIETY  
EST. 1865





# Sutured instanton homology and Heegaard diagrams

John A. Baldwin, Zhenkun Li and Fan Ye

## ABSTRACT

Suppose  $\mathcal{H}$  is an admissible Heegaard diagram for a balanced sutured manifold  $(M, \gamma)$ . We prove that the number of generators of the associated sutured Heegaard Floer complex is an upper bound on the dimension of the sutured instanton homology  $SHI(M, \gamma)$ . It follows, in particular, that strong L-spaces are instanton L-spaces.

## 1. Introduction

Let  $(M, \gamma)$  be a balanced sutured manifold. Kronheimer and Mrowka conjectured [KM10] that its sutured instanton homology is isomorphic to its sutured Heegaard Floer homology,

$$SHI(M, \gamma) \cong SFH(M, \gamma) \otimes \mathbb{C}. \quad (1.1)$$

Proving this remains a major open problem. In particular, it would imply isomorphisms

$$I^\#(Y) \cong \widehat{HF}(Y) \otimes \mathbb{C},$$

$$KHI(Y, K) \cong \widehat{HFK}(Y, K) \otimes \mathbb{C},$$

between the invariants of closed 3-manifolds and knots in the instanton and Heegaard Floer settings.

There has been a flood of recent work proving these isomorphisms for various families of closed 3-manifolds and knots; see [BS21, ABDS22, LPCS20, LY22, GL19]. In this paper, we initiate a systematic approach to the general isomorphism (1.1). Before stating our main result, let us establish some notation.

Given a sutured Heegaard diagram

$$\mathcal{H} = (\Sigma, \alpha = \{\alpha_1, \dots, \alpha_k\}, \beta = \{\beta_1, \dots, \beta_k\})$$

for a balanced sutured manifold  $(M, \gamma)$ , let

$$\mathbb{T}_\alpha := \alpha_1 \times \dots \times \alpha_k \quad \text{and} \quad \mathbb{T}_\beta := \beta_1 \times \dots \times \beta_k \subset \text{Sym}^k(\Sigma)$$

denote the usual tori in the  $k$ -fold symmetric product of  $\Sigma$ , and let

$$\mathfrak{S}(\mathcal{H}) := \mathbb{T}_\alpha \cap \mathbb{T}_\beta \subset \text{Sym}^k(\Sigma).$$

---

Received 19 November 2020, accepted in final form 9 March 2023, published online 28 July 2023.

2020 Mathematics Subject Classification 57K18, 57K31, 57K41 (primary).

Keywords: Floer homology, Heegaard diagrams, instanton, sutured manifold.

JAB was supported by NSF CAREER Grant DMS-1454865 and NSF FRG Grant DMS-1952707.

© 2023 The Author(s). This is an Open Access article, distributed under the terms of the Creative Commons Attribution licence (<https://creativecommons.org/licenses/by/4.0>), which permits unrestricted re-use, distribution, and reproduction in any medium, provided the original work is properly cited. *Compositio Mathematica* is © Foundation Compositio Mathematica.

If  $\mathcal{H}$  is *admissible*, then  $\mathfrak{S}(\mathcal{H})$  is the set of generators for the sutured Heegaard Floer complex  $SFC(\mathcal{H})$  as defined by Juhász in [Juh06].<sup>1</sup> Our main theorem is the following.

THEOREM 1.1. *If  $\mathcal{H}$  is an admissible sutured Heegaard diagram for  $(M, \gamma)$ , then*

$$\dim_{\mathbb{C}} SHI(M, \gamma) \leq |\mathfrak{S}(\mathcal{H})|.$$

Remark 1.2. Theorem 1.1 does not hold without the assumption that  $\mathcal{H}$  is admissible; see Remark 3.6.

Remark 1.3. Our proof of Theorem 1.1 also works for sutured monopole homology (*SHM*) in place of *SHI*. Of course, the *SHM* version of our main result follows from the isomorphism

$$SHM(M, \gamma) \cong SFH(M, \gamma),$$

which is a consequence of the equivalence between monopole and Heegaard Floer homology, see [Lek13]. Still, it may be of value to know that one can prove the inequality

$$\dim_{\mathbb{Z}} SHM(M, \gamma) \leq |\mathfrak{S}(\mathcal{H})|$$

without going through the proof of this equivalence.

Given a balanced sutured manifold  $(M, \gamma)$ , we define the *simultaneous trajectory number*  $\mathcal{T}(M, \gamma)$  to be the minimum of  $|\mathfrak{S}(\mathcal{H})|$  over all admissible sutured Heegaard diagrams  $\mathcal{H}$  for  $(M, \gamma)$ . This is the generalization to balanced sutured manifolds of a notion originally defined for rational homology 3-spheres by Ozsváth and Szabó in [OS04a]. It admits a purely Morse-theoretic interpretation when  $H_1(M, \partial M; \mathbb{Q}) = 0$ , and is a measure of the topological complexity of  $(M, \gamma)$ ; for example,  $\mathcal{T}(M, \gamma) = 1$  if and only if  $(M, \gamma)$  is a product sutured manifold.<sup>2</sup> Further, it is clear from the definition that

$$\text{rk}_{\mathbb{Z}} SFH(M, \gamma) \leq \mathcal{T}(M, \gamma).$$

We have the following immediate corollary of Theorem 1.1.

COROLLARY 1.4. *If  $(M, \gamma)$  is a balanced sutured manifold, then*

$$\dim_{\mathbb{C}} SHI(M, \gamma) \leq \mathcal{T}(M, \gamma).$$

For the following corollaries, we recall the natural sutured manifolds associated to closed 3-manifolds and knots therein. Given a closed 3-manifold  $Y$ , let  $(Y(1), \delta)$  denote the sutured manifold obtained by removing a 3-ball from  $Y$ , where  $\delta$  is a simple closed curve on  $\partial Y(1) \cong S^2$ . Similarly, given a knot  $K \subset Y$ , let  $(Y(K), m \cup -m)$  be the sutured manifold obtained by removing a tubular neighborhood of  $K$ , where  $m$  and  $-m$  are oppositely oriented meridional curves on  $\partial Y(K) \cong T^2$ . The framed instanton and Heegaard Floer homologies of a closed 3-manifold  $Y$  are given by

$$I^\#(Y) \cong SHI(Y(1), \delta),$$

$$\widehat{HF}(Y) \cong SFH(Y(1), \delta).$$

Likewise the instanton and Heegaard knot Floer homologies of a knot  $K \subset Y$  are given by

$$KHI(Y, K) \cong SHI(Y(K), m \cup -m),$$

$$\widehat{HFK}(Y, K) \cong SFH(Y(K), m \cup -m).$$

<sup>1</sup> See § 3.2 for the definition of *admissible*; every  $\mathcal{H}$  is admissible when  $H_1(M, \partial M; \mathbb{Q}) = 0$ .

<sup>2</sup> This is a fun exercise which we have not seen written down before: it is a generalization of the well-known fact that  $S^3$  is the only closed 3-manifold with simultaneous trajectory number one [OS04a].

Recall that the ranks of the Heegaard Floer homology and framed instanton homology of a rational homology 3-sphere  $Y$  are each bounded below by  $|H_1(Y)|$ . An  $L$ -space, respectively *instanton L-space*, is a rational homology 3-sphere which achieves these lower bounds

$$\begin{aligned} \text{rk}_{\mathbb{Z}} \widehat{HF}(Y) &= |H_1(Y)|, \\ \dim_{\mathbb{C}} I^{\#}(Y) &= |H_1(Y)|, \end{aligned}$$

respectively. A *strong L-space*, as defined by Levine and Lewallen in [LL12], is a rational homology 3-sphere  $Y$  which satisfies the stronger condition<sup>3</sup>

$$\mathcal{T}(Y(1), \delta) = |H_1(Y)|.$$

Indeed, this condition implies that  $Y$  is an L-space, because

$$|H_1(Y)| \leq \text{rk}_{\mathbb{Z}} \widehat{HF}(Y) \leq \mathcal{T}(Y(1), \delta).$$

The following is then an immediate corollary of Theorem 1.1.

**COROLLARY 1.5.** *If  $Y$  is a strong L-space, then it is an instanton L-space.*

More generally, we say that a sutured Heegaard diagram  $\mathcal{H}$  for a sutured manifold  $(M, \gamma)$  is *strong* if  $\mathcal{H}$  is admissible and the sutured Floer complex  $SFC(\mathcal{H})$  has trivial differential. We then have the following.

**COROLLARY 1.6.** *If  $(M, \gamma)$  is a balanced sutured manifold which has a strong sutured Heegaard diagram, then*

$$\dim_{\mathbb{C}} SHI(M, \gamma) \leq \text{rk}_{\mathbb{Z}} SFH(M, \gamma).$$

For example, when  $K$  is a  $(1, 1)$ -knot in a lens space  $L(p, q)$ , the sutured manifold

$$SHI((L(p, q))(K), m \cup -m)$$

has a strong Heegaard diagram. We thus reproduce the following result of Li and Ye [LY22].

**COROLLARY 1.7.** *If  $K \subset L(p, q)$  is a  $(1, 1)$ -knot, then*

$$\dim_{\mathbb{C}} KHI(L(p, q), K) \leq \text{rk}_{\mathbb{Z}} \widehat{HFK}(L(p, q), K).$$

### 1.1 On the proof

Given a vertical tangle  $T$  in a balanced sutured manifold  $(M, \gamma)$ , one forms an associated sutured manifold  $(M_T, \gamma_T)$  by removing a neighborhood of  $T$  from  $M$ , and adding meridians of the components of  $T$  to  $\gamma$ ; see § 2 for more details. Li and Ye proved the following dimension inequality in [LY22, Proposition 3.14].

**THEOREM 1.8.** *If  $T$  is a vertical tangle in  $(M, \gamma)$  such that  $[T_i] = 0$  in  $H_1(M, \partial M; \mathbb{Q})$  for each component  $T_i$  of  $T$ , then*

$$\dim_{\mathbb{C}} SHI(M, \gamma) \leq \dim_{\mathbb{C}} SHI(M_T, \gamma_T).$$

To prove Theorem 1.1, we first establish the same inequality under the weaker assumption that  $T$  (rather than each of its components) is rationally nullhomologous, in § 2.

**THEOREM 1.9.** *If  $T$  is a vertical tangle in  $(M, \gamma)$  such that  $[T] = 0$  in  $H_1(M, \partial M; \mathbb{Q})$ , then*

$$\dim_{\mathbb{C}} SHI(M, \gamma) \leq \dim_{\mathbb{C}} SHI(M_T, \gamma_T).$$

---

<sup>3</sup> Strong L-spaces are also of interest because Levine and Lewallen were able to show that their fundamental groups are not left-orderable, as predicted by the L-space Conjecture.

Next, given an admissible sutured Heegaard diagram  $\mathcal{H}$  for  $(M, \gamma)$ , we construct a vertical tangle  $T \subset (M, \gamma)$  with  $[T] = 0$  in  $H_1(M, \partial M; \mathbb{Q})$ , such that

$$\dim_{\mathbb{C}} SHI(M_T, \gamma_T) = |\mathfrak{S}(\mathcal{H})|.$$

This is the content of § 3. Theorem 1.1 then follows from Theorem 1.9.

*Remark 1.10.* Theorem 1.8 suffices to prove Theorem 1.1 in the case where  $H_1(M, \partial M; \mathbb{Q}) = 0$ , but we need the stronger Theorem 1.9 in general.

### 1.2 Organization

In § 2, we prove the inequality in Theorem 1.9. We then use this in § 3 to prove our main result, Theorem 1.1. Finally, in § 4, we discuss further directions, some of which are in progress. In particular, we discuss the possibility of using the proof of Theorem 1.1 to construct a grading on  $SHI$  by homotopy classes of 2-plane fields, and the prospects for upgrading Theorem 1.1 to a proof of the isomorphism (1.1).

## 2. A dimension inequality

A *vertical tangle* in a balanced sutured manifold  $(M, \gamma)$  is a properly embedded 1-manifold

$$T = T_1 \cup \dots \cup T_n$$

in  $M$ , with boundary in  $R(\gamma)$ , whose components  $T_i$  satisfy

$$\partial T_i \cap R_+(\gamma) \neq \emptyset \neq \partial T_i \cap R_-(\gamma),$$

and are oriented from  $R_+(\gamma)$  to  $R_-(\gamma)$  (in particular,  $T$  has no closed components). One forms an associated balanced sutured manifold  $(M_T, \gamma_T)$  by removing tubular neighborhoods of the components  $T_i$ , and adding positively-oriented meridians of these components to the suture  $\gamma$ , as in [LY22, § 3] and depicted in Figure 7. In this section, we prove Theorem 1.9, which states that

$$\dim_{\mathbb{C}} SHI(M, \gamma) \leq \dim_{\mathbb{C}} SHI(M_T, \gamma_T)$$

when  $[T] = 0$  in  $H_1(M, \partial M; \mathbb{Q})$ . The rough idea is to turn  $T$  into a related tangle  $T'$  whose components are rationally nullhomologous, and apply Theorem 1.8.

*Proof of Theorem 1.9.* Let  $T_1, \dots, T_n$  be the components of  $T$ . For  $i = 1, \dots, n$ , let

$$\partial T_i = q_i - p_i,$$

where  $p_i \in R_+(\gamma)$  and  $q_i \in R_-(\gamma)$ . We may assume that  $\gamma$  is connected, because we can achieve this by adding contact 1-handles to  $(M, \gamma)$ , an operation which does not change  $SHI(M, \gamma)$  (equivalently,  $SHI$  is invariant under product disk decomposition [KM10, BS16]). Then we can find a sequence of pairwise disjoint arcs

$$\xi_1, \dots, \xi_n \subset \partial M$$

such that, for each  $i = 1, \dots, n$ , we have:

- $\partial \xi_i = p_{i+1} - q_i$  (where  $p_{n+1} := p_1$ ); and
- $\xi_i$  intersects  $\gamma$  in exactly one point.

For every  $i \in \{2, \dots, n\}$ , choose an arc  $t_i \subset \partial M$  in a neighborhood of the unique intersection point  $\xi_{i-1} \cap \gamma$ , as depicted in Figures 1 and 2. Push the interior of  $t_i$  into the interior of  $M$  to

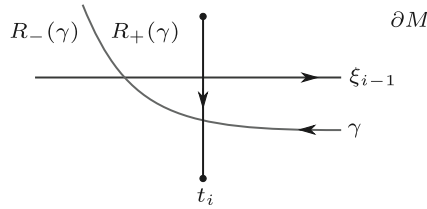

FIGURE 1. The point of view is from the interior of  $M$ , looking at  $\partial M$ .

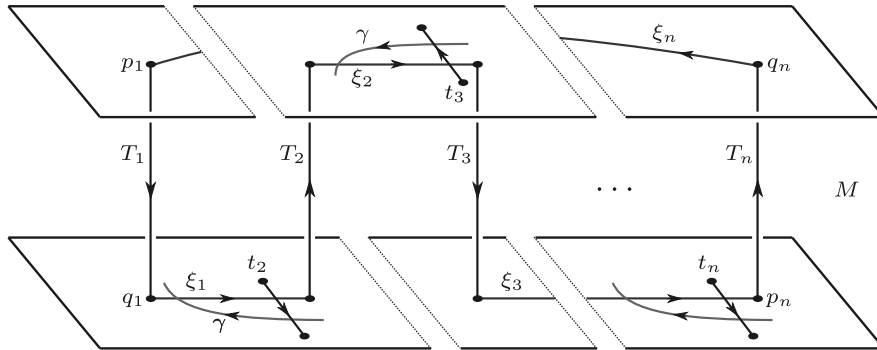

FIGURE 2. The tangle  $T = T_1 \cup \dots \cup T_n$  in  $M$  and the arcs  $\xi_i$  and  $t_i$  in  $\partial M$ , together with the suture  $\gamma$ .

turn this arc into a vertical tangle  $T'_i$ , and let

$$T'' = T'_2 \cup \dots \cup T'_n.$$

Then

$$(M_{T''}, \gamma_{T''}) = (M - N(T''), \gamma \cup \mu'_2 \cup \dots \cup \mu'_n),$$

where  $\mu'_i$  is a positively oriented meridian of  $T'_i$ . Each component  $T'_i$  cobounds a disk in  $M$  with the arc  $t_i$ . These disks then restrict to properly embedded disks

$$D_2, \dots, D_n \subset M_{T''}$$

with  $|D_i \cap \gamma| = 1$  and  $|D_i \cap \mu'_j| = \delta_{ij}$ , so that

$$|D_i \cap \gamma_{T''}| = 2.$$

Thus, each  $D_i$  is a product disk.

Next, consider the arc

$$t_1 = T_1 \cup \xi_1 \cup T_2 \cup \xi_2 \cup \dots \cup T_{n-1} \cup \xi_{n-1} \cup T_n \subset M_{T''}.$$

Push its interior into the interior of  $M_{T''}$  to form a vertical tangle  $T'_1$  with  $\partial T'_1 = q_n - p_1$ , as in Figure 3. Let  $T'$  be the tangle in  $M$  given by

$$T' = T'_1 \cup T'' = T'_1 \cup \dots \cup T'_n.$$

We refer to a tangle  $T'$  formed in this way as a *mixed tangle for  $T$* . Note that

$$(M_{T'}, \gamma_{T'}) = ((M_{T''})_{T'_1}, (\gamma_{T''})_{T'_1}) = (M - N(T'), \gamma \cup \mu'_1 \cup \dots \cup \mu'_n),$$

where  $\mu'_1$  is a positively oriented meridian of  $T'_1$ . Observe that the disks  $D_2, \dots, D_n \subset M_{T''}$  restrict to properly embedded annuli

$$A_2, \dots, A_n \subset M_{T'}$$

because  $T'_1$  intersects each disk in exactly one point, as shown in Figure 4.

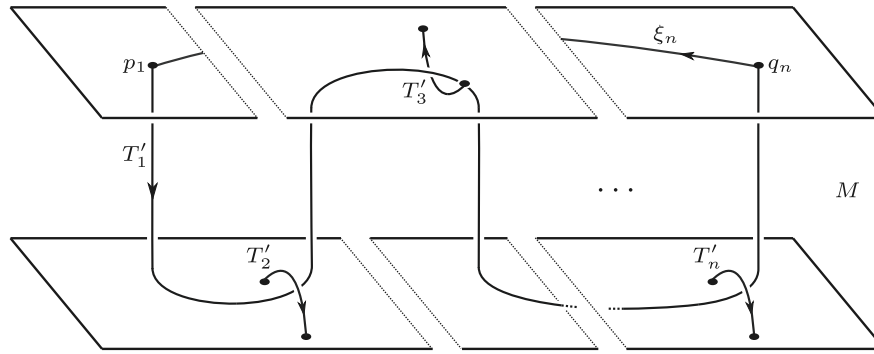

FIGURE 3. The tangle  $T' = T'_1 \cup \dots \cup T'_n$  in  $M$ .

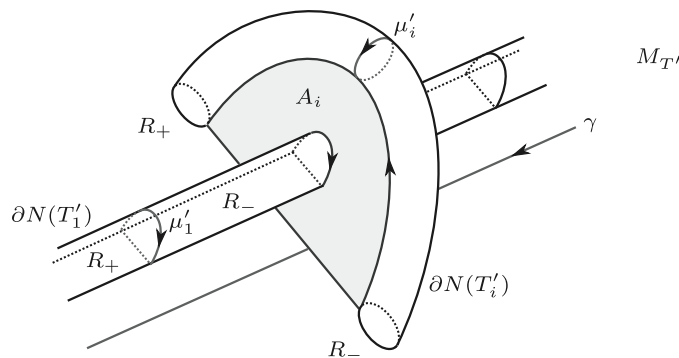

FIGURE 4. The annulus  $A_i$  in  $M_{T'}$  near the boundaries of the tubular neighborhoods of the components  $T'_1$  and  $T'_i$ , as seen from inside  $M_{T'}$ .

The endpoints of the arc  $\xi_n \subset \partial M_{T''}$  agree with  $\partial T'_1$ , and  $|\xi_n \cap \gamma| = 1$ . We can, thus, use  $\xi_n$  together with  $\gamma$  and  $\mu'_1$  to define a sequence of sutures  $\Gamma_m \subset \partial M_{T''}$  for  $m \in \mathbb{N}$ , as in [LY22, § 3.2], which one should regard as ‘longitudinal’ sutures for  $T'_1$ ; see Figure 5. By the construction of  $T'_1$  and the assumption that  $T$  is rationally nullhomologous in  $(M, \partial M)$ , we have

$$[T'_1] = [T] = 0 \in H_1(M_{T''}, \partial M_{T''}; \mathbb{Q}).$$

Therefore, by [LY22, Lemmas 3.21 and 3.22], we have the following.

LEMMA 2.1. *There is an exact triangle*

$$\begin{array}{ccc} SHI(-M_{T'}, -\Gamma_m) & \longrightarrow & SHI(-M_{T'}, -\Gamma_{m+1}) \\ & \swarrow G_m & \searrow F_{m+1} \\ & SHI(-M_{T''}, -\gamma_{T''}) & \end{array}$$

coming from the surgery exact triangle associated to surgeries on the meridian  $\mu'_1$  of  $T'_1$ . Furthermore,  $G_m \equiv 0$  for  $m$  sufficiently large.

For each  $i = 2, \dots, n$  and every  $m \in \mathbb{N}$ , we have that

$$|A_i \cap \Gamma_m| = 4.$$

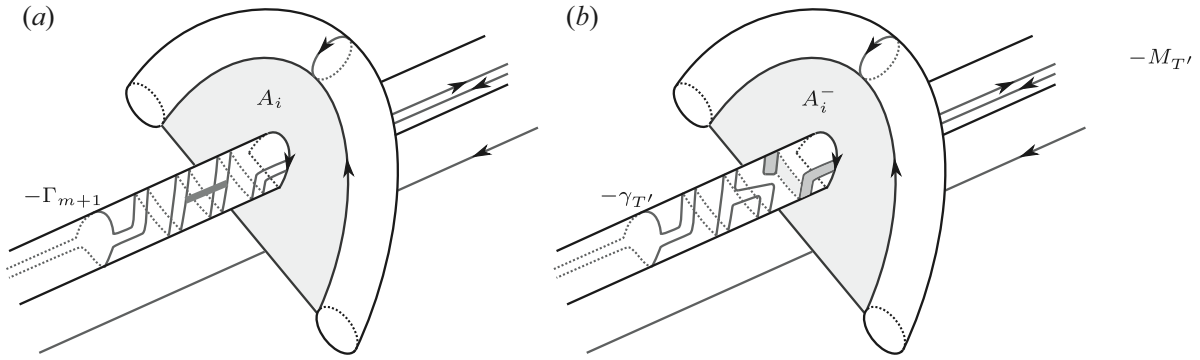

FIGURE 5. (a) The suture  $-\Gamma_{m+1}$  and the bypass arc  $\eta_-$  shown in bold. (b) The suture  $-\gamma_{T'}$  resulting from the bypass attachment along  $\eta_-$ , and the negatively stabilized annulus  $A_i^- \subset (-M_{T'}, -\gamma_{T'})$ .

Let us orient each  $A_i$  so that the induced orientation on  $\partial A_i$  is opposite the orientation of  $\partial D_i$  coming from that of  $T'_i$ , as in Figures 4 and 5. By [GL19], the disks  $D_2, \dots, D_n$  induce a  $\mathbb{Z}^{n-1}$ -grading on

$$SHI(-M_{T''}, -\gamma_{T''}).$$

Similarly, the annuli  $A_2, \dots, A_n$  induce a  $\mathbb{Z}^{n-1}$ -grading on

$$SHI(-M_{T'}, -\Gamma_m)$$

for each  $m \in \mathbb{N}$ , and we have the following graded version of the triangle in Lemma 2.1.

LEMMA 2.2. *The exact triangle of Lemma 2.1 restricts to the exact triangle*

$$\begin{array}{ccc} SHI(-M_{T'}, -\Gamma_m, (A_2, \dots, A_n), (0, \dots, 0)) & \longrightarrow & SHI(-M_{T'}, -\Gamma_{m+1}, (A_2, \dots, A_n), (0, \dots, 0)) \\ & \swarrow G_m & \searrow F_{m+1} \\ & SHI(-M_{T''}, -\gamma_{T''}, (D_2, \dots, D_n), (0, \dots, 0)) & \end{array}$$

*Proof of Lemma 2.2.* We prove that the map  $F_{m+1}$  preserves the gradings. The arguments for the other two maps are similar.

Let us first recall the definition of  $F_{m+1}$  from [LY22, § 3]. Pick a *closure*

$$(Y_{m+1}, R_{m+1}, \omega_{m+1})$$

for  $(-M_{T'}, -\Gamma_{m+1})$  so that each annulus  $A_i$  extends to a closed surface  $\bar{A}_i \subset Y_{m+1}$ , as in [Li21, § 3]. By the construction therein,

$$g(\bar{A}_i) = 2$$

for  $i = 2, \dots, n$ , because each component of  $\partial A_i$  intersects  $\Gamma_{m+1}$  in two points. The sutured instanton homology of  $(-M_{T'}, -\Gamma_{m+1})$  is defined as a certain direct summand

$$SHI(-M_{T'}, -\Gamma_{m+1}) = I_*(Y_{m+1} | R_{m+1})_{\omega_{m+1}}$$

of the instanton Floer homology  $I_*(Y_{m+1})_{\omega_{m+1}}$  as in [KM10, § 7]. The summand

$$SHI(-M_{T'}, -\Gamma_{m+1}, (A_2, \dots, A_n), (i_2, \dots, i_n))$$



is defined as the simultaneous (generalized)  $(2i_2, \dots, 2i_n)$ -eigenspace of commuting operators

$$\mu(\bar{A}_2), \dots, \mu(\bar{A}_n) : SHI(-M_{T'}, -\Gamma_{m+1}) \rightarrow SHI(-M_{T'}, -\Gamma_{m+1})$$

associated to these surfaces.

The meridian  $\mu'_1$  of  $T'_1$  can be thought of as an embedded circle in  $Y_{m+1}$ . Let  $Y$  be the manifold obtained from  $Y_{m+1}$  via 0-surgery on  $\mu'_1$ , with respect to the framing of  $\mu'_1$  induced by  $\partial M_{T'}$ . Since  $\mu'_1$  is disjoint from  $R_{m+1}$  and the  $\bar{A}_i$ , these surfaces survive in  $Y$ . By [BS16, § 3.3],  $(Y, R_{m+1}, \omega_{m+1})$  is a closure of  $(-M_{T''}, -\gamma_{T''})$ . The map  $F_{m+1}$  is then induced by the cobordism given by the trace of 0-surgery on  $\mu'_1$ . Since  $\bar{A}_i \subset Y_{m+1}$  is homologous to  $\bar{A}_i \subset Y$  in this cobordism,  $F_{m+1}$  respects the eigenspaces of  $\mu(\bar{A}_i)$ . Thus,  $F_{m+1}$  maps

$$SHI(-M_{T'}, -\Gamma_{m+1}, (A_2, \dots, A_n), (i_2, \dots, i_n))$$

into

$$SHI(-M_{T''}, -\gamma_{T''}, (A_2, \dots, A_n), (i_2, \dots, i_n)).$$

Now, the 0-surgery on  $\mu'_1$  makes each  $\bar{A}_i$  compressible in  $Y$ ; in particular, each  $\bar{A}_i \subset Y$  is homologous to the disjoint union of two tori

$$T_i^1 \cup T_i^2 \subset Y.$$

One of these tori, say  $T_i^1$ , is the extension  $\bar{D}_i \subset Y$  of  $D_i \subset -M_{T''}$  that is used to define the grading on  $SHI(-M_{T''}, -\gamma_{T''})$  associated to  $D_i$ . Since

$$\bar{A}_i = \bar{D}_i + T_i^2$$

in  $H_2(Y)$ , the  $k$ -eigenspace of  $\mu(\bar{A}_i)$  agrees with the  $k$ -eigenspace of  $\mu(\bar{D}_i)$  for every  $k$ , by [BS22, Corollary 2.9]. Thus, we have that

$$\begin{aligned} &SHI(-M_{T''}, -\gamma_{T''}, (A_2, \dots, A_n), (i_2, \dots, i_n)) \\ &= SHI(-M_{T''}, -\gamma_{T''}, (D_2, \dots, D_n), (i_2, \dots, i_n)). \end{aligned}$$

Putting these arguments together, we see that  $F_{m+1}$  preserves the  $\mathbb{Z}^{n-1}$ -gradings as claimed in the lemma. □

Note that decomposing  $(-M_{T''}, -\gamma_{T''})$  along  $D_2 \cup \dots \cup D_n$  yields  $(-M, -\gamma)$ . By [Li21, Lemma 4.2], we therefore have

$$SHI(-M_{T''}, -\gamma_{T''}, (D_2, \dots, D_n), (0, \dots, 0)) \cong SHI(-M, -\gamma).$$

Hence, for  $m$  sufficiently large, Lemmas 2.1 and 2.2 imply that

$$\begin{aligned} \dim_{\mathbb{C}} SHI(-M, -\gamma) &= \dim_{\mathbb{C}} SHI(-M_{T'}, -\Gamma_{m+1}, (A_2, \dots, A_n), (0, \dots, 0)) \\ &\quad - \dim_{\mathbb{C}} SHI(-M_{T'}, -\Gamma_m, (A_2, \dots, A_n), (0, \dots, 0)), \end{aligned} \tag{2.1}$$

since  $G_m \equiv 0$ .

Next, we consider attaching a bypass to  $(-M_{T'}, -\Gamma_{m+1})$  along the arc  $\eta_-$  in Figure 5. By [BS22, § 4], this attachment gives rise to a bypass exact triangle. As discussed in [LY22, § 3], the other two sutures involved in the triangle are  $-\Gamma_m$  and  $-\gamma_{T'}$ . It is straightforward to check that the bypass attachment along  $\eta_-$  creates a *negative stabilization*

$$A_i^- \subset (-M_{T'}, -\gamma_{T'})$$

of  $A_i$ , for each  $i = 2, \dots, n$ , in the sense of [Li21, Definition 3.1]. Hence, as in the proof of [Li21, Proposition 5.5], we have the following graded version of the bypass exact triangle of

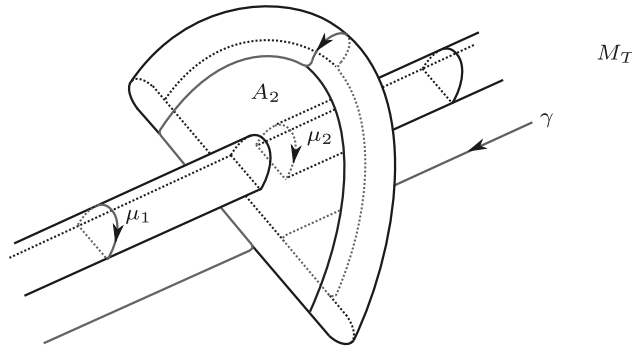

FIGURE 6. The result of decomposing  $(M_{T'}, \gamma_{T'})$  along  $A_2 \cup \dots \cup A_n$  is simply  $(M_T, \gamma_T)$ . This is illustrated above in the case  $n = 2$ .

[BS22, Theorem 1.20]:

$$\begin{array}{ccc}
 SHI(-M_{T'}, -\Gamma_m, (A_2, \dots, A_n), (0, \dots, 0)) & \longrightarrow & SHI(-M_{T'}, -\Gamma_{m+1}, (A_2, \dots, A_n), (0, \dots, 0)) \\
 \swarrow & & \searrow \\
 & SHI(-M_{T'}, -\gamma_{T'}, (A_2^-, \dots, A_n^-), (0, \dots, 0)) &
 \end{array}$$

which implies that

$$\begin{aligned}
 & \dim_{\mathbb{C}} SHI(-M_{T'}, -\gamma_{T'}, (A_2^-, \dots, A_n^-), (0, \dots, 0)) \\
 & \geq \dim_{\mathbb{C}} SHI(-M_{T'}, -\Gamma_{m+1}, (A_2, \dots, A_n), (0, \dots, 0)) \\
 & \quad - \dim_{\mathbb{C}} SHI(-M_{T'}, -\Gamma_m, (A_2, \dots, A_n), (0, \dots, 0)).
 \end{aligned} \tag{2.2}$$

From the grading shifting property [Li21, Theorem 1.12] and [Wan20, Proposition 4.1], we have

$$\begin{aligned}
 & SHI(-M_{T'}, -\gamma_{T'}, (A_2^-, \dots, A_n^-), (0, \dots, 0)) \\
 & = SHI(-M_{T'}, -\gamma_{T'}, (A_2^+, \dots, A_n^+), (-1, \dots, -1)),
 \end{aligned} \tag{2.3}$$

where  $A_i^+$  is a *positive stabilization* of  $A_i$ . Moreover, from the construction of the gradings and stabilizations in [Li21, §3], we have

$$\begin{aligned}
 & SHI(-M_{T'}, -\gamma_{T'}, (A_2^+, \dots, A_n^+), (-1, \dots, -1)) \\
 & = SHI(-M_{T'}, -\gamma_{T'}, (-(A_2^+), \dots, -(A_n^+)), (1, \dots, 1)) \\
 & = SHI(-M_{T'}, -\gamma_{T'}, ((-A_2)^-, \dots, (-A_n)^-), (1, \dots, 1)).
 \end{aligned} \tag{2.4}$$

By [Li21, Lemma 4.2], this last group is isomorphic to the sutured instanton homology of the manifold obtained from  $(-M_{T'}, -\gamma_{T'})$  by decomposing along  $(-A_2)^- \cup \dots \cup (-A_n)^-$ . By [Li21, Lemma 3.2], this is the same as the manifold obtained by decomposing along  $-A_2 \cup \dots \cup -A_n$ , which is, after reversing orientation, the manifold obtained from  $(M_{T'}, \gamma_{T'})$  by decomposing along  $A_2 \cup \dots \cup A_n$ . It is straightforward to check that the latter manifold is simply  $(M_T, \gamma_T)$ , as indicated in Figure 6 in the case  $n = 2$ . Thus,

$$SHI(-M_{T'}, -\gamma_{T'}, ((-A_2)^-, \dots, (-A_n)^-), (1, \dots, 1)) \cong SHI(-M_T, -\gamma_T). \tag{2.5}$$

Finally, combining (2.1)–(2.5), we have that

$$\begin{aligned} \dim_{\mathbb{C}} SHI(-M_T, -\gamma_T) &= \dim_{\mathbb{C}} SHI(-M_{T'}, -\gamma_{T'}, ((-A_2)^-, \dots, (-A_n)^-), (1, \dots, 1)) \\ &= \dim_{\mathbb{C}} SHI(-M_{T'}, -\gamma_{T'}, (A_2^-, \dots, A_n^-), (0, \dots, 0)) \\ &\geq \dim_{\mathbb{C}} SHI(-M_{T'}, -\Gamma_{m+1}, (A_2, \dots, A_n), (0, \dots, 0)) \\ &\quad - \dim_{\mathbb{C}} SHI(-M_{T'}, -\Gamma_m, (A_2, \dots, A_n), (0, \dots, 0)) \\ &= \dim_{\mathbb{C}} SHI(-M, -\gamma). \end{aligned}$$

Given the symmetry of  $SHI$  under orientation reversal, this proves Theorem 1.9. □

### 3. Proof of Theorem 1.1

#### 3.1 Full tangles

Let  $(M, \gamma)$  be a balanced sutured manifold. Let

$$\mathcal{H} = (\Sigma, \alpha = \{\alpha_1, \dots, \alpha_k\}, \beta = \{\beta_1, \dots, \beta_k\})$$

be any (not necessarily admissible) sutured Heegaard diagram for  $(M, \gamma)$ . This means that  $M$  is obtained from  $\Sigma \times [-1, 1]$  by attaching 3-dimensional 2-handles

$$\begin{aligned} \mathbb{D}_{\alpha_i} &= D_{\alpha_i}^2 \times I, \\ \mathbb{D}_{\beta_i} &= D_{\beta_i}^2 \times I, \end{aligned}$$

along  $A_i \times \{-1\}$  and  $B_i \times \{+1\}$ , where  $A_i$  and  $B_i$  are annular neighborhoods of  $\alpha_i$  and  $\beta_i$ , respectively, for  $i = 1, \dots, k$ . The suture  $\gamma$  is given by

$$\gamma = \partial\Sigma \times \{0\}.$$

We next define a special class of vertical tangles in  $(M, \gamma)$  associated to  $\mathcal{H}$ .

Let  $R_1, \dots, R_n$  be the regions of  $\Sigma - \alpha - \beta$  disjoint from  $\partial\Sigma$ . For each  $i = 1, \dots, n$ , let  $p_{i1}, \dots, p_{ia_i}$  be  $a_i$  distinct points in  $R_i$ , for some integer  $a_i \geq 1$ . Let

$$T_{ij} = p_{ij} \times [-1, 1] \subset \Sigma \times [-1, 1],$$

and let

$$T = \bigcup_{i=1}^n \bigcup_{j=1}^{a_i} T_{ij}.$$

Then  $T$  is a vertical tangle in  $(M, \gamma)$ , oriented from  $R_+(\gamma)$  to  $R_-(\gamma)$ . Let  $D_{ij}^2$  be a tubular neighborhood of the point  $p_{ij} \in R_i$ , let

$$N_{ij} = D_{ij}^2 \times [-1, 1]$$

be a tubular neighborhood of the component  $T_{ij}$  in  $M$ , and let

$$\gamma_{ij} = \partial D_{ij}^2 \times \{0\} \subset \partial N_{ij}$$

be a positively oriented meridian of this component; see Figure 7. Let  $(M_T, \gamma_T)$  be the balanced sutured manifold obtained from  $M$  by removing these tubular neighborhoods,

$$M_T = M - \bigcup_{i=1}^n \bigcup_{j=1}^{a_i} N_{ij},$$

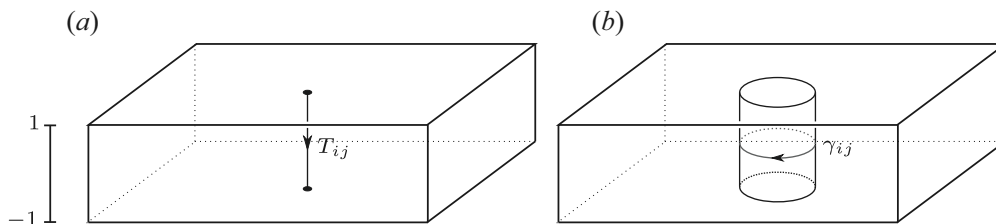

FIGURE 7. (a) The component  $T_{ij} = p_{ij} \times [-1, 1] \subset M$ . (b) The complement of  $N_{ij}$  with the meridian  $\gamma_{ij}$ .

where  $\gamma_T$  is the union of  $\gamma$  with meridians of the  $T_{ij}$ ,

$$\gamma_T = \gamma \cup \bigcup_{i=1}^n \bigcup_{j=1}^{a_i} \gamma_{ij},$$

as in §2. We refer to any tangle obtained in this way as a *full tangle* for  $\mathcal{H}$ .

The main result of this section is the following.

PROPOSITION 3.1. *If  $T$  is a full tangle for  $\mathcal{H}$ , then  $\dim_{\mathbb{C}} SHI(M_T, \gamma_T) = |\mathfrak{S}(\mathcal{H})|$ .*

Remark 3.2. The analogue of this proposition for *SFH* is immediate. One forms a sutured Heegaard diagram  $\mathcal{H}_T$  for  $(M_T, \gamma_T)$  from  $\mathcal{H}$  by removing neighborhoods of the  $p_{ij} \in \Sigma$ . Since there is at least one such point in every region of  $\Sigma - \alpha - \beta$  not intersecting  $\partial\Sigma$ , this ensures that  $\mathcal{H}_T$  is admissible and that the differential on *SFC*( $\mathcal{H}_T$ ) is zero, so that

$$\text{rk}_{\mathbb{Z}} SFH(M_T, \gamma_T) = \text{rk}_{\mathbb{Z}} SFC(\mathcal{H}_T) = |\mathfrak{S}(\mathcal{H}_T)| = |\mathfrak{S}(\mathcal{H})|.$$

This was the inspiration for our result above.

We need the following for the proof of Proposition 3.1; see [GL19, Corollary 4.3].

PROPOSITION 3.3. *Suppose  $(M, \gamma)$  is an irreducible balanced sutured manifold and  $D \subset M$  is a properly embedded disk which intersects  $\gamma$  in four points. Then*

$$SHI(M, \gamma) \cong SHI(M', \gamma') \oplus SHI(M'', \gamma''),$$

where  $(M', \gamma')$  and  $(M'', \gamma'')$  are the decompositions of  $(M, \gamma)$  along  $D$  and  $-D$ , respectively.

Before proving this proposition, we record the following lemma. This lemma is well-known (Kronheimer and Mrowka prove the much harder converse in [KM10, Theorem 7.12]), but since we could not find a concrete reference in the literature we provide a short proof here.

LEMMA 3.4. *Suppose  $(M, \gamma)$  is an irreducible balanced sutured manifold. If  $(M, \gamma)$  is not taut, then  $SHI(M, \gamma) = 0$ .*

*Proof.* As mentioned in the proof of Lemma 2.2,  $SHI(M, \gamma)$  is defined in [KM10, §7] in terms of a *closure*  $(Y, R, \omega)$  of  $(M, \gamma)$ , where  $Y$  is a closed oriented 3-manifold,  $R \subset Y$  is a connected closed oriented surface which we can take to have genus  $g(R) > 1$ , and  $\omega \subset Y$  is a simple closed curve with  $|\omega \cap R| = 1$ . Specifically,  $SHI(M, \gamma)$  is the generalized  $(2g(R) - 2)$ -eigenspace of the operator  $\mu(R)$  on  $I_*(Y)_{\omega}$ .

Now suppose that  $(M, \gamma)$  is irreducible but not taut. Then, by the definition of tautness (e.g. [Juh06, Definition 9.18]), either one of  $R_{\pm}(\gamma)$  is compressible or  $R_{\pm}(\gamma)$  do not minimize the Thurston-norm in their homology classes. In either case, there exists a surface  $R' \subset Y$  such

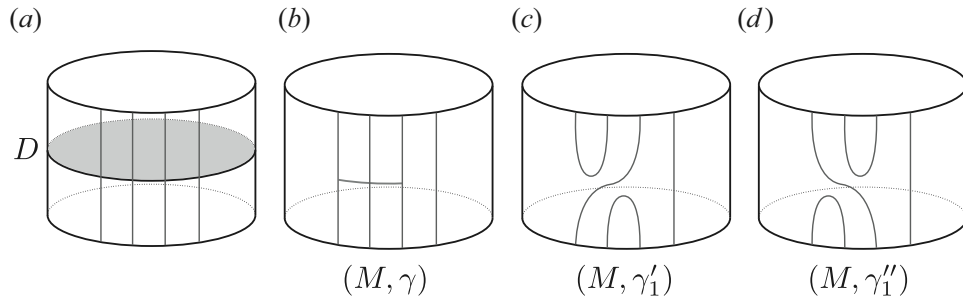

FIGURE 8. (a) A neighborhood of the disk  $D \subset M$  whose boundary intersects the suture  $\gamma$  in four points. (b–d) The arc of attachment for the initial bypass in the triangle.

that  $[R'] = [R] \in H_2(Y)$  but  $1 \leq g(R') < g(R)$ . This implies that  $SHI(M, \gamma) = 0$  by [KM10, Proposition 7.5].  $\square$

*Proof of Proposition 3.3.* Ghosh and Li prove this in [GL19, Corollary 4.3] under the additional assumption that  $(M, \gamma)$  is taut and at least one of  $(M', \gamma')$  and  $(M'', \gamma'')$  is taut. We show that this additional assumption is unnecessary, by showing that the proposition still holds when the assumption is not true.

First, suppose  $(M, \gamma)$  is not taut. Then neither  $(M', \gamma')$  nor  $(M'', \gamma'')$  is taut, by [Gab87, Lemma 0.4]. Note that the irreducibility of  $M$  implies the irreducibility of any manifold obtained by cutting  $M$  open along a properly embedded disk; in particular,  $M'$  and  $M''$  are irreducible. Therefore,

$$SHI(M, \gamma) \cong SHI(M', \gamma') \cong SHI(M'', \gamma'') = 0,$$

by Lemma 3.4, and the proposition holds.

Next, suppose neither  $(M', \gamma')$  nor  $(M'', \gamma'')$  is taut. Consider the bypass exact triangle of [BS22]:

$$\begin{array}{ccc} SHI(-M, -\gamma) & \longrightarrow & SHI(-M, -\gamma'_1) \\ & \swarrow & \searrow \\ & SHI(-M, -\gamma''_1) & \end{array}$$

determined by an initial bypass attachment to  $(M, \gamma)$  along an arc in  $\partial D$  as shown in Figure 8. The other manifolds  $(M, \gamma'_1)$  and  $(M, \gamma''_1)$  in the triangle product disk decompose (along a copy of  $D$  which intersects the new sutures in two points) to  $(M', \gamma')$  and  $(M'', \gamma'')$ , respectively. Since  $SHI$  is invariant under product disk decomposition, we therefore have

$$\begin{aligned} SHI(M, \gamma'_1) &\cong SHI(M', \gamma') \cong 0, \\ SHI(M, \gamma''_1) &\cong SHI(M'', \gamma'') \cong 0, \end{aligned}$$

by Lemma 3.4. It then follows from the bypass triangle, and the symmetry of  $SHI$  under orientation reversal, that  $SHI(M, \gamma) = 0$  as well, so the proposition holds.  $\square$

*Proof of Proposition 3.1.* Recall that  $D_{ij}^2$  denotes a tubular neighborhood of  $p_{ij} \in R_i$ . There exists a (possibly empty) set of disjoint, properly embedded arcs

$$d_1, \dots, d_m \subset \Sigma - \bigcup_{i=1}^n \bigcup_{j=1}^{a_i} D_{ij}$$

which satisfy the following three conditions:

- (1) for every  $e = 1, \dots, m$ , the arc  $d_e$  is contained in some region of  $\Sigma - \alpha - \beta$ ;
- (2) for every  $e$ , either both endpoints of  $d_e$  are on  $\partial\Sigma$ , or each is on some  $\partial D_{ij}^2$ ; and
- (3)  $\Sigma - \bigcup_{i=1}^n \bigcup_{j=1}^{a_i} D_{ij} - d_1 - \dots - d_m$  deformation retracts onto  $\alpha \cup \beta$ .

Now consider the disk

$$\delta_e = d_e \times [-1, 1] \subset \left( \Sigma - \bigcup_{i=1}^n \bigcup_{j=1}^{a_i} D_{ij} \right) \times [-1, 1] \subset \partial M_T,$$

for  $e = 1, \dots, m$ . The boundary of each  $\delta_e$  intersects  $\gamma_T$  in two points; hence,  $\delta_e$  is a product disk. Since *SHI* is invariant under product disk decomposition, let  $(M_T, \gamma_T)$  henceforth refer to the balanced sutured manifold obtained after decomposing along  $\delta_1, \dots, \delta_m$ .

Then  $M_T$  admits the following description. Let  $q_1, \dots, q_t$  denote the intersection points between the  $\alpha$  and  $\beta$  curves. If  $q_\ell$  is an intersection point between  $\alpha_i$  and  $\beta_j$ , let  $r_\ell \subset \Sigma$  denote the rectangular component of  $A_i \cap B_j$  which contains  $q_\ell$ . Then  $M_T$  is the given by the union

$$M_T = \mathbb{D}_{\alpha_1} \cup \dots \cup \mathbb{D}_{\alpha_k} \cup \mathbb{D}_{\beta_1} \cup \dots \cup \mathbb{D}_{\beta_k} \cup \tau_1 \cup \dots \cup \tau_t$$

of the usual 2-handles with the *tubes*

$$\tau_\ell = r_\ell \times [-1, 1],$$

as shown in [Figure 9](#). Let  $c_\ell$  denote the union of the four corners of the rectangle  $r_\ell$ . Then the suture  $\gamma_T$  is given by

$$\gamma_T = \bigcup_{i=1}^k (\partial D_{\alpha_i}^2 \times \partial I) \cup \bigcup_{i=1}^k (\partial D_{\beta_i}^2 \times \partial I) \cup \bigcup_{\ell=1}^t (c_\ell \times [-1, 1]) - \bigcup_{\ell=1}^t (\partial r_\ell \times \{-1, 1\})$$

as shown and oriented in the figure near a tube  $\tau_\ell$ . Let

$$m_\ell = r_\ell \times \{0\} \subset \tau_\ell$$

denote the meridional disk of  $\tau_\ell$ , oriented as in [Figure 9](#), for  $\ell = 1, \dots, t$ . Note that the boundary of each  $m_\ell$  intersects the suture  $\gamma_T$  in four points.

Note that  $M_T$  is a handlebody and therefore irreducible. We may thus apply [Proposition 3.3](#) to it, as well as to the manifolds obtained by decomposing  $M_T$  along any collection of the meridional disks  $m_\ell$ , as these manifolds are simply disjoint unions of handlebodies and, hence, also irreducible. For each  $t$ -tuple of signs

$$I = (\epsilon_1, \dots, \epsilon_t) \in \{+, -\}^t,$$

let  $(M_T^I, \gamma_T^I)$  be the sutured manifold obtained by decomposing  $(M_T, \gamma_T)$  along the disks

$$\epsilon_1 m_1 \cup \dots \cup \epsilon_t m_t.$$

Then

$$SHI(M_T, \gamma_T) \cong \bigoplus_{I \in \{+, -\}^t} SHI(M_T^I, \gamma_T^I),$$

by [Proposition 3.3](#). Each  $(M_T^I, \gamma_T^I)$  is simply a union of 3-balls

$$M_T^I \cong \mathbb{D}_{\alpha_1} \cup \dots \cup \mathbb{D}_{\alpha_k} \cup \mathbb{D}_{\beta_1} \cup \dots \cup \mathbb{D}_{\beta_k},$$

which means that  $SHI(M_T^I, \gamma_T^I)$  is either  $\mathbb{C}$  or trivial, according as whether  $\gamma_T^I$  has exactly one component on the boundary of each of these 3-balls or not. We claim that the nonzero

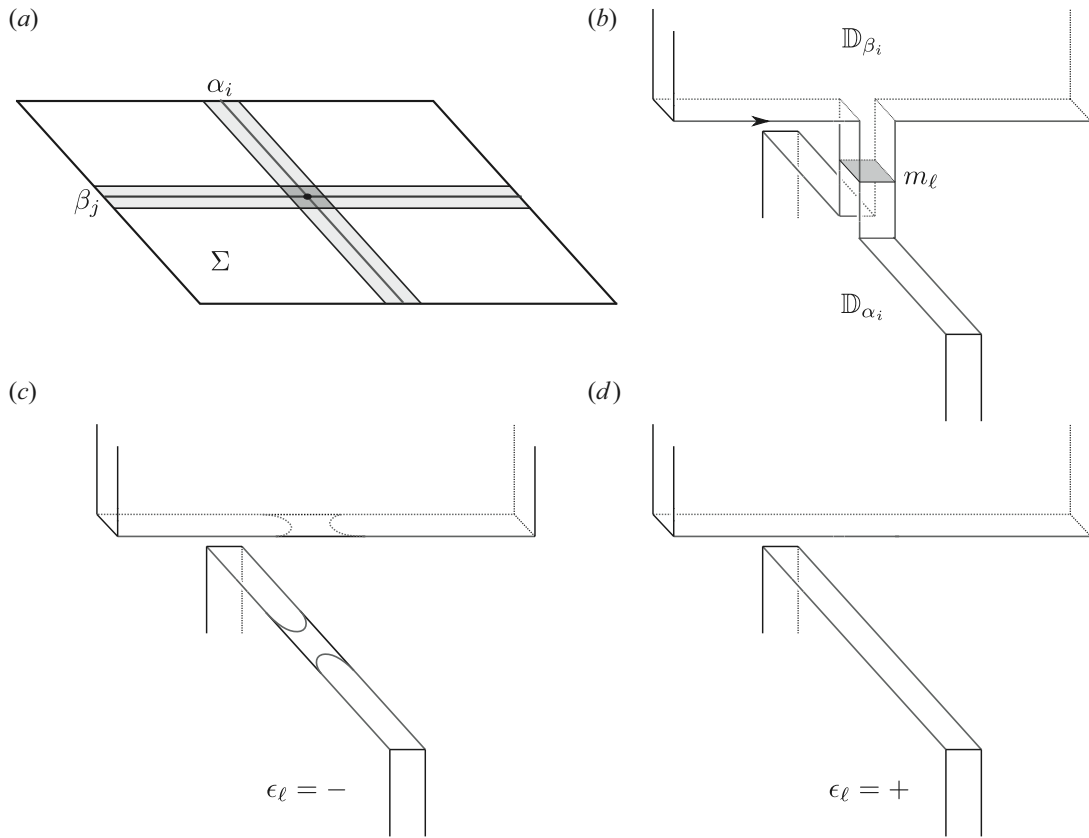

FIGURE 9. (a) An intersection point  $q_\ell \in \alpha_i \cap \beta_j$ . The rectangular component  $r_\ell$  of  $A_i \cap B_j$  containing  $q_\ell$  is shown in darker gray. (b) The 2-handles  $\mathbb{D}_{\alpha_i}$  and  $\mathbb{D}_{\beta_j}$  glued together by the tube  $\tau_\ell$ . The meridional disk  $m_\ell$  is shown in gray; it intersects the suture  $\gamma_T$  in four points, and its oriented normal points upwards. (c) The result of decomposing along  $-m_\ell$ . (d) The result of decomposing along  $m_\ell$ .

summands  $SHI(M_T^I, \gamma_T^I)$  are in one-to-one correspondence with the elements of  $\mathfrak{S}(\mathcal{H})$ , which will then complete the proof.

For this claim, we consider the restriction of  $\gamma_T^I$  to the ball  $\mathbb{D}_{\alpha_i}$ . Let

$$q_{\ell_1}, \dots, q_{\ell_p} \in \{q_1, \dots, q_t\}$$

denote the intersection points between  $\alpha_i$  and  $\beta$ . Then  $\gamma_T^I$  restricts to exactly one component on the boundary of  $\mathbb{D}_{\alpha_i}$  if and only if exactly one of  $\epsilon_{\ell_1}, \dots, \epsilon_{\ell_p}$  is  $-$  and the rest are  $+$ . The analogous statement holds for the restriction of  $\gamma_T^I$  to  $\mathbb{D}_{\beta_j}$ . Thus, if we let

$$q(I) = \{q_\ell \mid \epsilon_\ell = -\},$$

then  $\gamma_T^I$  restricts to exactly one component on each 3-ball in  $M_T^I$  if and only if  $q(I) \in \mathfrak{S}(\mathcal{H})$ .  $\square$

*Remark 3.5.* Proposition 3.1 also follows from the fact that  $SHI$  and  $SFH$  obey the same decomposition laws (Proposition 3.3, and the invariance under product disk decomposition), agree in rank for sutured 3-balls, and

$$\text{rk}_{\mathbb{Z}} SFH(M_T, \gamma_T) = |\mathfrak{S}(\mathcal{H})|,$$

per Remark 3.2. Our original proof has the advantages that it does not rely on the definition of the differential in *SFC*, and it establishes a very concrete bijection between the nonzero summands  $SHI(M_T^I, \gamma_T^I)$  and elements of  $\mathfrak{S}(\mathcal{H})$ .

### 3.2 The proof

Recall that a sutured Heegaard diagram  $\mathcal{H}$  for a balanced sutured manifold  $(M, \gamma)$  is *admissible* if and only if every nontrivial periodic domain has both positive and negative multiplicities [Juh06]. This is automatically true of any  $\mathcal{H}$  when  $H_1(M, \partial M; \mathbb{Q}) = 0$  (there are no nontrivial periodic domains in this case), though every balanced sutured manifold admits an admissible diagram.

*Proof of Theorem 1.1.* Let  $\mathcal{H} = (\Sigma, \alpha, \beta)$  be an admissible sutured Heegaard diagram for  $(M, \gamma)$ . Then we can assign a positive integer area  $a_i$  to each region  $R_i$  of  $\Sigma - \alpha - \beta$  disjoint from  $\partial \Sigma$ , so that the signed area of every periodic domain is zero; see [OS04b, Lemma 4.12].<sup>4</sup> Fix  $a_i$  distinct points  $p_{i1}, \dots, p_{ia_i} \in R_i$  for each  $i$ , and let

$$T = \bigcup_{i=1}^n \bigcup_{j=1}^{a_i} T_{ij} \subset M$$

be the corresponding full tangle for  $\mathcal{H}$ , as in §3.1.

We claim that  $[T] = 0$  in  $H_1(M, \partial M; \mathbb{Q})$ . To see this, note that for every periodic domain  $P$  of  $\mathcal{H}$ , the intersection number of  $T$  with the 2-cycle in  $M$  represented by  $P$  is negative the signed area of  $P$ , which is zero. Since the homology classes represented by periodic domains span  $H_2(M)$ , the claim follows. Theorem 1.9 therefore implies that

$$\dim_{\mathbb{C}} SHI(M, \gamma) \leq \dim_{\mathbb{C}} SHI(M_T, \gamma_T).$$

Theorem 1.1 then follows from the fact that

$$\dim_{\mathbb{C}} SHI(M_T, \gamma_T) = |\mathfrak{S}(\mathcal{H})|,$$

by Proposition 3.1. □

*Remark 3.6.* It is not true that the inequality

$$\dim_{\mathbb{C}} SHI(M, \gamma) \leq |\mathfrak{S}(\mathcal{H})|$$

holds for *any* sutured Heegaard diagram  $\mathcal{H}$  for an arbitrary balanced sutured  $(M, \gamma)$ . For example, consider the diagram  $\mathcal{H} = (T^2 - D^2, \alpha_1, \beta_1)$  for

$$(M, \gamma) = ((S^1 \times S^2)(1), \delta)$$

in which  $\alpha_1$  and  $\beta_1$  are disjoint curves on the punctured torus. In this case, we know that

$$\dim_{\mathbb{C}} SHI(M, \gamma) = 2,$$

while  $|\mathfrak{S}(\mathcal{H})| = 0$ . The issue here is that  $\mathcal{H}$  is not admissible.

### 4. Further directions

Let  $\mathcal{H}$  be an admissible sutured Heegaard diagram for a balanced sutured manifold  $(M, \gamma)$ . Let  $T$  be a full tangle for  $\mathcal{H}$ , as defined in §3. In ongoing work, we prove that

$$SHI(-M_T, -\gamma_T) \cong \mathbb{C}^{|\mathfrak{S}(\mathcal{H})|}$$

---

<sup>4</sup> Ozsváth and Szabó state this for real-valued areas, but proof shows the same is true for integer areas.



has a basis given by the contact invariants of the tight contact structures on  $(M_T, \gamma_T)$ . In particular, this sutured instanton homology group is naturally graded by homotopy classes of 2-plane fields. We discuss potential applications of this fact in the following.

Let  $T'$  be a mixed tangle for  $T$ , as defined in § 2. Let  $V_T$  and  $V_m$  be the groups

$$V_T = SHI(-M_{T'}, -\gamma_{T'}, (A_2^-, \dots, A_n^-), (0, \dots, 0)),$$

$$V_m = SHI(-M_{T'}, -\Gamma_m, (A_2, \dots, A_n), (0, \dots, 0))$$

from § 2, for  $m \in \mathbb{N}$ . To prove Theorem 1.1, we proved that  $V_T \cong SHI(-M_T, -\gamma_T)$  and

$$\dim_{\mathbb{C}} SHI(-M, -\gamma) = \dim_{\mathbb{C}} V_{m+1} - \dim_{\mathbb{C}} V_m \leq \dim_{\mathbb{C}} V_T$$

for sufficiently large  $m$ . However, in fact, this inequality can be viewed as coming from a spectral sequence similar to that in [LY22, § 4]. This spectral sequence can also be described as follows. From the bypass exact triangle used in § 2, we have that

$$V_T \cong H_*(\text{Cone}(\psi_- : V_m \rightarrow V_{m+1})),$$

where  $\psi_-$  is the map associated to the bypass attachment along the arc  $\eta_-$ . One can prove, on the other hand, that

$$SHI(-M, -\gamma) \cong H_*(\text{Cone}(\psi_- - \psi_+ : V_m \rightarrow V_{m+1}))$$

for  $m$  large, where  $\psi_+$  is a related bypass attachment map. The groups  $V_m$  and  $V_{m+1}$  can be graded using the rational Seifert surface for  $T'$ , as in [Li21]. After adjusting this grading by an overall shift, the map  $\psi_-$  is grading-preserving while  $\psi_+$  decreases the grading by 1, for  $m$  large. The complex  $\text{Cone}(\psi_- - \psi_+)$  is then filtered, and the  $E_1$  page of the associated spectral sequence is  $H_*(\text{Cone}(\psi_-))$ . In sum, we have a spectral sequence

$$\mathbb{C}^{|\mathfrak{S}(\mathcal{H})|} \cong V_T \cong H_*(\text{Cone}(\psi_-)) \implies H_*(\text{Cone}(\psi_- - \psi_+)) \cong SHI(-M, -\gamma). \tag{4.1}$$

The first potential application of these ideas involves defining a grading on  $SHI(-M, -\gamma)$  by homotopy classes of plane fields. Indeed,  $SHI(-M_T, -\gamma_T)$  has such a grading, as mentioned previously, as it is generated by contact invariants of contact structures. The manifold  $(M_{T'}, \gamma_{T'})$  is obtained by gluing  $(M_T, \gamma_T)$  along annuli, as in § 2, and we believe that the tight contact structures on the latter glue to give tight contact structures on the former whose invariants form a basis for  $V_T$ . Thus, there should be a natural grading by homotopy classes of 2-plane fields on  $V_T$  as well. The bypass maps  $\psi_-, \psi_+$  are natural from a contact-geometric standpoint, and should therefore shift plane field gradings in a sensible way. We expect that one can then use the relation between  $V_T$  and  $\text{Cone}(\psi_-)$  and the structure of the latter to define a plane field grading on  $\text{Cone}(\psi_-)$ , and then on  $\text{Cone}(\psi_- - \psi_+)$ .

A grading by homotopy classes of 2-plane fields on  $SHI$  would enable one to define  $\text{Spin}^c$  decompositions of these groups, as well as an analogue of the Maslov grading in Heegaard Floer homology (see [LY22, § 4] for another approach to such a decomposition). The current lack of such structure makes it difficult to translate arguments from the Heegaard Floer setting to the instanton Floer setting.

A related second application is towards proving the isomorphism (1.1). Indeed, there is some hope that one could understand the spectral sequence (4.1) purely in terms of contact geometry, and thereby obtain a more axiomatic proof that

$$SHI(M, \gamma) \cong SFH(M, \gamma) \otimes \mathbb{C} \cong SHM(M, \gamma) \otimes \mathbb{C}, \tag{4.2}$$

since the analogous spectral sequences can be defined in the Heegaard Floer and monopole Floer settings by the same contact-geometric means.

A more pedestrian approach to (4.2) is the following: first, prove that one can understand the spectral sequence

$$\mathbb{C}^{|\mathfrak{S}(\mathcal{H})|} \implies SHI(-M, -\gamma)$$

as coming from a differential

$$\partial = \partial_1 + \partial_2 + \dots : \mathbb{C}^{|\mathfrak{S}(\mathcal{H})|} \rightarrow \mathbb{C}^{|\mathfrak{S}(\mathcal{H})|},$$

where  $\partial_k$  shifts a grading (coming from homotopy classes of 2-plane fields) on  $\mathbb{C}^{|\mathfrak{S}(\mathcal{H})|} \cong V_T$  by  $k$ , such that

$$SHI(-M, -\gamma) \cong H_*(\mathbb{C}^{|\mathfrak{S}(\mathcal{H})|}, \partial).$$

Then, for generators  $x, y \in \mathfrak{S}(\mathcal{H})$  and the corresponding basis elements  $e_x, e_y \in \mathbb{C}^{|\mathfrak{S}(\mathcal{H})|}$ , perhaps one could use the 2-plane field gradings to show that the coefficient

$$\langle \partial e_x, e_y \rangle \tag{4.3}$$

is nonzero only if there is a homotopy class of Whitney disks

$$\varphi \in \pi_2(x, y) \tag{4.4}$$

with positive domain in  $\mathcal{H}$  and Maslov index one. If even this were true, then one could prove, for example, that the inequality in Corollary 1.7 is an equality,

$$\dim_{\mathbb{C}} KHI(L(p, q), K) \leq \text{rk}_{\mathbb{Z}} \widehat{HFK}(L(p, q), K)$$

for  $(1, 1)$ -knots  $K \subset L(p, q)$ .

More generally, the hope would be that for a *nice* diagram  $\mathcal{H}$  (one in which the regions of  $\Sigma - \alpha - \beta$  disjoint from  $\partial\Sigma$  are bigons or rectangles), one could show that the coefficient (4.3) is nonzero if and only if there is a class as in (4.4) with positive domain and Maslov index one (the domain of such a class is necessarily an empty embedded bigon or rectangle in this case). These are precisely the domains counted in the differential on  $SFC(\mathcal{H})$  in this case, by [SW10]. If one could further show that these domains are counted with the *same* nonzero complex coefficients in both the sutured instanton and Heegaard Floer settings, then this would prove (1.1) and then (4.2) by the same methods. If one could work with coefficients in  $\mathbb{F} = \mathbb{Z}/2\mathbb{Z}$ , then the last step would be unnecessary, as all nonzero elements of this field are equal. Unfortunately,  $SHI$  is not defined over  $\mathbb{F}$ . On the other hand,  $SHM$  is, and therefore the strategy outlined above minus the last step would be sufficient to give an alternative, more axiomatic proof that

$$SFH(M, \gamma; \mathbb{F}) \cong SHM(M, \gamma; \mathbb{F}).$$

ACKNOWLEDGEMENTS

We thank A. Levine, T. Lidman, S. Sivek, and J. Wang for interesting conversations, and the referee for helpful comments.

CONFLICTS OF INTEREST

None.

REFERENCES

ABDS22 A. Alfieri, J. A. Baldwin, I. Dai and S. Sivek, *Instanton Floer homology of almost-rational plumbings*, *Geom. Topol.* **26** (2022), 2237–2294.  
 BS16 J. A. Baldwin and S. Sivek, *Instanton Floer homology and contact structures*, *Selecta Math. (N.S.)* **22** (2016), 939–978.

- BS21 J. A. Baldwin and S. Sivek, *Framed instanton homology and concordance*, J. Topol. **14** (2021), 1113–1175.
- BS22 J. A. Baldwin and S. Sivek, *Khovanov homology detects the trefoils*, Duke Math. J. **171** (2022), 885–956.
- Gab87 D. Gabai, *Foliations and the topology of 3-manifolds. II*, J. Differential Geom. **26** (1987), 461–478.
- GL19 S. Ghosh and Z. Li, *Decomposing sutured monopole and instanton Floer homologies*, Preprint (2019). [arXiv:1910.10842](https://arxiv.org/abs/1910.10842).
- Juh06 A. Juhász, *Holomorphic discs and sutured manifolds*, Algebr. Geom. Topol. **6** (2006), 1429–1457.
- KM10 P. Kronheimer and T. Mrowka, *Knots, sutures, and excision*, J. Differential Geom. **84** (2010), 301–364.
- Lek13 Y. Lekili, *Heegaard-Floer homology of broken fibrations over the circle*, Adv. Math. **244** (2013), 268–302.
- LL12 A. S. Levine and S. Lewallen, *Strong L-spaces and left orderability*, Math. Res. Lett. **19** (2012), 1237–1244.
- Li21 Z. Li, *Knot homologies in monopole and instanton theories via sutures*, J. Symplectic Geom. **19** (2021), 1339–1420.
- LY22 Z. Li and F. Ye, *Instanton Floer homology, sutures, and Heegaard diagrams*, J. Topol. **15** (2022), 39–107.
- LPCS20 T. Lidman, J. Pinzón-Caicedo and C. Scaduto, *Framed instanton homology of surgeries on L-space knots*, Preprint (2020), [arXiv:2003.03329](https://arxiv.org/abs/2003.03329).
- OS04a P. Ozsváth and Z. Szabó, *Holomorphic disks and three-manifold invariants: properties and applications*, Ann. of Math. **159** (2004), 1159–1245.
- OS04b P. Ozsváth and Z. Szabó, *Holomorphic disks and topological invariants for closed three-manifolds*, Ann. of Math. **159** (2004), 1027–1158.
- SW10 S. Sarkar and J. Wang, *An algorithm for computing some Heegaard Floer homologies*, Ann. of Math. **171** (2010), 1213–1236.
- Wan20 J. Wang, *The cosmetic crossing conjecture for split links*, Preprint (2020), [arXiv:2006.01070](https://arxiv.org/abs/2006.01070).

John A. Baldwin [john.baldwin@bc.edu](mailto:john.baldwin@bc.edu)

Department of Mathematics, Boston College, Maloney Hall, Chestnut Hill, MA 02467-3806, USA

Zhenkun Li [zhenkun@stanford.edu](mailto:zhenkun@stanford.edu)

Department of Mathematics, Stanford University, Building 380, Stanford, CA 94305, USA

Fan Ye [fanye@math.harvard.edu](mailto:fanye@math.harvard.edu)

Department of Mathematics, Harvard University, 1 Oxford Street, Cambridge, MA 02138, USA

*Compositio Mathematica* is owned by the Foundation Compositio Mathematica and published by the London Mathematical Society in partnership with Cambridge University Press. All surplus income from the publication of *Compositio Mathematica* is returned to mathematics and higher education through the charitable activities of the Foundation, the London Mathematical Society and Cambridge University Press.